



# **Dolby Multichannel Amplifier Manual**

Issue 4

Part Number 9112403

---

---

# Dolby Laboratories, Inc.

## Corporate Headquarters

**Dolby Laboratories, Inc.**  
1275 Market Street  
San Francisco, CA 94103-1410 USA  
**Telephone** 415-558-0200  
**Fax** 415-645-4000  
[www.dolby.com](http://www.dolby.com)

## European Headquarters

**Dolby International AB**  
Apollo Building, 3E  
Herikerbergweg 1-35  
1101 CN Amsterdam Zuidooost  
The Netherlands  
**Telephone** 31-20-651-1800  
**Fax** 31-20-651-1801

## Technical Support

Dolby Laboratories  
Portal: [www.dolbycustomer.com](http://www.dolbycustomer.com)  
Email: [cinemasupport@dolby.com](mailto:cinemasupport@dolby.com)

Region	Support Phone Numbers
Americas	+ 1-415-645-4900
EMEA	+ 44-33-0808-7700
APAC	+ 86-400-692-6780
Japan	+ 81-3-3524-7350

### **LIMITED WARRANTY:**

DOLBY WARRANTS TO THE ORIGINAL PURCHASER ONLY, THAT THE PRODUCT WILL BE FREE FROM DEFECTS IN MATERIALS AND WORKMANSHIP UNDER NORMAL CONSUMER USE FOR THE GREATER OF 1 YEAR, OR THE MINIMUM PERIOD REQUIRED UNDER LOCAL LAW, COMMENCING UPON THE DATE OF ORIGINAL RETAIL PURCHASE (THE "WARRANTY PERIOD"). THIS EXPRESS WARRANTY IS NON-TRANSFERABLE.

DOLBY'S SOLE LIABILITY, AND YOUR SOLE REMEDY, FOR DOLBY'S BREACH OF THE FOREGOING WARRANTY DURING THE WARRANTY PERIOD WILL BE, AT DOLBY'S SOLE DISCRETION, TO REPAIR OR REPLACE THE DEFECTIVE PRODUCT. THE FOREGOING IS YOUR SOLE AND EXCLUSIVE REMEDY FOR DOLBY'S BREACH OF THE WARRANTY HEREIN OR FOR ANY OTHER CLAIMS RELATED TO THIS WARRANTY.

### **WARRANTY EXCLUSIONS:**

THIS LIMITED WARRANTY DOES NOT COVER DAMAGE OR MALFUNCTIONS CAUSED BY ACCIDENT, DISASTER, MISUSE (INCLUDING ANY USE IN A MANNER CONTRARY TO THE INSTRUCTIONS CONTAINED IN ANY USER GUIDE OR ON THE PACKAGING OF THE PRODUCT), ABUSE, NEGLIGENCE OR OTHER EXTERNAL CAUSES; POWER SURGES; IMPROPER INSTALLATION; THIRD-PARTY PRODUCTS; UNAUTHORIZED OPENING, USE, SERVICE, TAMPERING, ALTERATION, REPAIR OR MODIFICATION; OR INADEQUATE PACKING OR SHIPPING PROCEDURES. THIS LIMITED WARRANTY ALSO DOES NOT COVER COSMETIC DAMAGE OR ISSUES INCIDENT TO NORMAL WEAR AND TEAR.

### **WARRANTY CLAIMS:**

IN ORDER TO MAKE A WARRANTY CLAIM, YOU MUST CONTACT [cinemasupport@dolby.com](mailto:cinemasupport@dolby.com) DURING THE WARRANTY PERIOD. A CINEMA SUPPORT REPRESENTATIVE WILL DETERMINE WHETHER THE PURPORTED DEFECT IS COVERED UNDER THE WARRANTY. IF COVERED, CINEMA SUPPORT WILL PROVIDE YOU DETAILED INFORMATION ON HOW AND WHERE TO SEND YOUR DEFECTIVE PRODUCT. FAILURE TO FOLLOW THE REPAIR RETURN INSTRUCTIONS MAY VOID YOUR WARRANTY.

---

**DISCLAIMER OF WARRANTIES:**

EQUIPMENT MANUFACTURED BY DOLBY LABORATORIES IS WARRANTED AGAINST DEFECTS IN MATERIALS AND WORKMANSHIP FOR A PERIOD OF ONE YEAR FROM THE DATE OF PURCHASE. THERE ARE NO OTHER EXPRESS OR IMPLIED WARRANTIES AND NO WARRANTY OF MERCHANTABILITY OR FITNESS FOR A PARTICULAR PURPOSE, OR OF NONINFRINGEMENT OF THIRD-PARTY RIGHTS (INCLUDING, BUT NOT LIMITED TO, COPYRIGHT AND PATENT RIGHTS).

**LIMITATION OF LIABILITY:**

IT IS UNDERSTOOD AND AGREED THAT DOLBY LABORATORIES' LIABILITY, WHETHER IN CONTRACT, IN TORT, UNDER ANY WARRANTY, IN NEGLIGENCE, OR OTHERWISE, SHALL NOT EXCEED THE COST OF REPAIR OR REPLACEMENT OF THE DEFECTIVE COMPONENTS OR ACCUSED INFRINGING DEVICES, AND UNDER NO CIRCUMSTANCES SHALL DOLBY LABORATORIES BE LIABLE FOR INCIDENTAL, SPECIAL, DIRECT, INDIRECT, OR CONSEQUENTIAL DAMAGES (INCLUDING, BUT NOT LIMITED TO, DAMAGE TO SOFTWARE OR RECORDED AUDIO OR VISUAL MATERIAL), COST OF DEFENSE, OR LOSS OF USE, REVENUE, OR PROFIT, EVEN IF DOLBY LABORATORIES OR ITS AGENTS HAVE BEEN ADVISED, ORALLY OR IN WRITING, OF THE POSSIBILITY OF SUCH DAMAGES.

**PATENTS:**

THIS PRODUCT MAY BE PROTECTED BY PATENTS AND PENDING PATENT APPLICATIONS IN THE UNITED STATES AND ELSEWHERE. FOR MORE INFORMATION, INCLUDING A SPECIFIC LIST OF PATENTS PROTECTING THIS PRODUCT, PLEASE VISIT <http://www.dolby.com/patents>.

**PRODUCT MODEL:**

THIS DOCUMENTATION APPLIES TO MODEL CID1001

---

---

---

## Regulatory Notices

### United States (FCC)

This equipment complies with Part 15 of the FCC rules. Operation is subject to the following conditions:

1. This device may not cause harmful interference.
2. This device must accept any interference received, including interference that may cause undesired operation.

This equipment has been tested and found to comply with the limits for a Class B digital device, pursuant to Part 15 of the FCC Rules. These limits are designed to provide reasonable protection against harmful interference in a residential installation. This equipment generates, uses, and can radiate radio frequency energy and, if not installed and used in accordance with the instructions, may cause harmful interference to radio communications. However, there is no guarantee that interference will not occur in a particular installation. If this equipment does cause harmful interference to radio or television reception (which can be determined by turning the equipment off and on), the user is encouraged to try to correct the interference by one or more of the following measures:

- Reorient or relocate the receiving antenna.
- Increase the separation between the equipment and receiver.
- Connect the equipment to an outlet on a circuit that is different from the outlet to which the receiver is connected.
- Consult the dealer or an experienced radio/TV technician for help.

Any changes or modifications to this product could void the authorization provided to the user to operate this device.

Properly shielded and grounded cables and connectors must be used for connection to other accessories and/or peripherals in order to meet FCC emission limits.

### Canada

This Class B digital apparatus complies with Canadian ICES-003.

Cet appareil numérique de la classe B est conforme à la norme NMB-003 du Canada.

### European Union

The power supply on this product has power factor correction. However, we recommend that you notify your supply company or authority prior to connecting.

A Declaration of Conformity is available upon request.

## Important Safety Instructions

1. Read these instructions.
2. Keep these instructions.
3. Heed all WARNINGS.
4. Follow all instructions.
5. WARNING: Do not use this apparatus near water.
6. WARNING: To reduce the risk of fire or electric shock, do not expose this apparatus to rain or moisture.
7. WARNING: To prevent electric shock, do not remove the top cover or attempt to service the unit in any way. There are no user-serviceable parts inside the unit. Refer all servicing and troubleshooting to qualified service personnel only.
8. Clean only with dry cloth.
9. Do not install near any heat sources such as radiators, heat registers, stoves, or other apparatus (including amplifiers) that produce heat.
10. No naked flame sources, such as lighted candles, should be placed on the apparatus.
11. Protect the power cord from being walked on or pinched, particularly at plugs, convenience receptacles, and the point where it exits from the apparatus.
12. Only use attachments/accessories specified by the manufacturer.
13. Unplug this apparatus when unused for long periods of time.
14. Refer all servicing to qualified service personnel. Servicing is required when the apparatus has been damaged in any way, such as the power-supply cord or plug is damaged, liquid has been spilled or objects have fallen into the apparatus, the apparatus has been exposed to rain or moisture, does not operate normally, or has been dropped.
15. Do not expose the apparatus to dripping or splashing, and no objects filled with liquids, such as vases, should be placed on the apparatus.
16. WARNING: Troubleshooting must be performed by a trained technician. To reduce the risk of electric shock, do not attempt to service this equipment unless you are qualified.
17. Do not defeat the safety purpose of the polarized or grounding-type plug. A polarized plug has two blades with one wider than the other. A grounding-type plug has two blades and a third grounding prong. The wide blade or the third prong is provided for your safety. If the provided plug does not fit into your outlet, consult an electrician for replacement of the obsolete outlet.
18. This apparatus must be earthed (grounded) by connecting to a correctly wired and earthed power outlet.
19. Ensure that your mains supply is in the correct range for the input power requirement of the unit.
20. This equipment is designed to mount in a suitably ventilated 19" rack; ensure that any ventilation slots in the unit are not blocked or covered.
21. To avoid exposure to dangerous voltages and to avoid damage to the unit, do not connect the rear-panel Ethernet port to telephone circuits.

22. As the colors of the cores in the mains lead may not correspond with the colored markings identifying the terminals in your plug, proceed as follows:
- The green or green and yellow core must be connected to the terminal in the plug identified by the letter E, or by the earth symbol , or colored green, or green and yellow.
  - The blue and brown cores must be connected to the power pins in the mains plug according to local code.

## Product End-Of-Life Information



This product was designed and built by Dolby Laboratories to provide many years of service, and is backed by our commitment to provide high-quality support. When it eventually reaches the end of its serviceable life, it should be disposed of in accordance with local or national legislation. For current information please visit our website: [www.dolby.com/environment](http://www.dolby.com/environment).

## Warning and Safety Symbols



This symbol that appears in this manual is intended to alert the user to the presence of uninsulated “dangerous” voltage within the product’s enclosure that may be of sufficient magnitude to constitute a risk of electric shock to persons.



This symbol that appears in this manual is intended to alert the user to the presence of important safety operating and maintenance instructions.



This symbol that appears on the unit rear panel and in this manual is intended to alert the user to the presence of uninsulated “dangerous” voltage within the product’s enclosure that may be of sufficient magnitude to constitute a risk of electric shock to persons.



This symbol that appears on the unit rear panel is intended to alert the user to the presence of important safety operating and maintenance instructions.



This symbol that appears on the unit rear panel is intended to alert the user that high voltage is present at the speaker output terminals and that these terminals should be handled and connected only by an authorized (trained) technician. Use Class-2 wiring for all speaker connections.

**IMPORTANT SAFETY NOTICE**

To ensure safe operation and to guard against potential shock hazard or risk of fire, the following **must** be observed:

- o Ensure that your mains supply is in the correct range for the input power requirement of the unit.
- o Ensure **fuses** fitted are the **correct rating and type** as marked on the unit.
- o The unit **must be earthed** by connecting to a correctly wired and **earthed** power outlet.
- o The **power cord** supplied with this unit must be wired as follows:  
Live—Brown    Neutral—Blue    Earth—Green/Yellow

GB

**IMPORTANT – NOTE DE SECURITE**

Pour vous assurer d'un fonctionnement sans danger et de prévenir tout choc électrique ou tout risque d'incendie, veuillez à ob les recommandations suivantes.

- o Le selecteur de tension doit être placé sur la valeur correspondante à votre alimentation réseau.
- o Les fusibles doivent correspondre à la valeur indiquée sur le materiel.
- o Le materiel doit être correctement relié à la terre.
- o Le cordon secteur livré avec le materiel doit être câblé de la manière suivante:  
Phase—Brun    Neutre—Bleu    Terre—Vert/Jaune

F

**WICHTIGER SICHERHEITSHINWEIS**

Für das sichere Funktionieren der Geräte und zur Unfallverhütung (elektrischer Schlag, Feuer) sind die folgenden Regeln unbedingt einzuhalten:

- o Der Spannungswähler muß auf Ihre Netzspannung eingestellt sein.
- o Die Sicherungen müssen in Typ und Stromwert mit den Angaben auf dem Gerät übereinstimmen.
- o Die Erdung des Gerätes muß über eine geerdete Steckdose gewährleistet sein.
- o Das mitgelieferte Netzkabel muß wie folgt verdrahtet werden:  
Phase—braun    Nulleiter—blau    Erde—grün/gelb

D

**NORME DI SICUREZZA – IMPORTANTE**

Per una perfetta sicurezza ed al fine di evitare eventuali rischi di scossa elettrica o d'incendio vanno osservate le seguenti misure di sicurezza:

- o Assicurarsi che il selettore di cambio tensione sia posizionato sul valore corretto.
- o Assicurarsi che la portata ed il tipo di fusibili siano quelli prescritti dalla casa costruttrice.
- o L'apparecchiatura deve avere un collegamento di messa a terra ben eseguito; anche la connessione rete deve avere un collegamento a terra.
- o Il cavo di alimentazione a corredo dell'apparecchiatura deve essere collegato come segue:  
Filo tensione—Marrone    Neutro—Blu    Massa—Verde/Giallo

I

**AVISO IMPORTANTE DE SEGURIDAD**

Para asegurarse un funcionamiento seguro y prevenir cualquier posible peligro de descarga o riesgo de incendio, se han de observar las siguientes precauciones:

- o Asegúrese que el selector de tensión esté ajustado a la tensión correcta para su alimentación.
- o Asegúrese que los fusibles colocados son del tipo y valor correctos, tal como se marca en la unidad.
- o La unidad debe ser puesta a tierra, conectándola a un conector de red correctamente cableado y puesto a tierra.
- o El cable de red suministrado con esta unidad, debe ser cableado como sigue:  
Vivo—Marrón    Neutro—Azul    Tierra—Verde/Amarillo

E

**VIKTIGA SÄKERHETSÅTGÄRDER!**

För att garantera säkerheten och gardera mot eventuell elchock eller brandrisk, måste följande obas:

- o Kontrollera att späningsväljaren är inställd på korrekt nätspänning.
- o Kontrollera att säkringarna är av rätt typ och för rätt strömstyrka så som anvisningarna på enheten föreskriver.
- o Enheten måste vara jordad genom anslutning till ett korrekt kopplat och jordat el-uttag.
- o El-sladden som medföljer denna enhet måste kopplas enligt följande:  
Fas—Brun    Neutral—Blå    Jord—Grön/Gul

S

**BELANGRIJK VEILIGHEIDS-VOORSCHRIFT:**

Voor een veilig gebruik en om het gevaar van elektrische schokken en het risico van brand te vermijden, dienen de volgende regels in acht te worden genomen:

- o Controleer of de spanningscarroussel op het juiste Voltage staat.
- o Gebruik alleen zekeringen van de aangegeven typen en waarden.
- o Aansluiting van de unit alleen aan een geaarde wandcontactdoos.
- o De netkabel die met de unit wordt geleverd, moet als volgt worden aangesloten:  
Fase—Bruin    Nul—Blauw    Aarde—Groen/Geel

NL

---

# Table of Contents

<b>Chapter 1 Introduction .....</b>	<b>1</b>
1.1 Dolby Multichannel Amplifier Front Panel.....	1
1.1.1 LED Channel and System Status .....	2
1.1.2 Power Button .....	2
1.1.3 USB Port.....	3
1.2 Dolby Multichannel Amplifier Rear Panel .....	3
1.2.1 AC Mains Power Inlet .....	3
1.2.2 Dolby Atmos Connect In/Out RJ45 Ports.....	3
1.2.3 Command (Com) RJ45 Port .....	3
1.2.4 Terminal Block Connectors.....	3
<b>Chapter 2 Installing the Dolby Multichannel Amplifier.....</b>	<b>5</b>
2.1 Rack Mounting Instructions .....	5
2.1.1 Preparing for Setup .....	6
2.1.2 Installing the Dolby Multichannel Amplifier in a Rack .....	7
2.1.3 Additional Requirements.....	9
2.2 Connecting AC Power .....	10
2.3 Connecting Audio Input .....	10
2.4 Connecting a Single Dolby Multichannel Amplifier .....	11
2.5 Connecting Two Dolby Multichannel Amplifiers.....	13
2.5.1 Using Dolby Multichannel Amplifiers or DAC3202s with a Switch .....	15
2.6 Connecting the Output Channels to the Speakers .....	16
2.6.1 Connecting Channels in Normal Mode .....	17
2.6.2 Connecting Channels in Bridge Mode .....	18
<b>Chapter 3 Using the Dolby Multichannel Amplifier .....</b>	<b>19</b>
3.1 Connecting to the Dolby Multichannel Amplifier .....	20
3.2 Navigation Bar .....	21
3.2.1 Status.....	22
3.2.2 Network.....	23
3.2.3 Maintenance .....	26
3.2.4 Power.....	29
3.2.5 Routing.....	31
3.2.6 Audio Controls .....	32
3.2.7 Delay.....	33
3.2.8 User Access.....	34
3.2.9 Reboot .....	34
3.2.10 Documentation .....	34
<b>Appendix A Specifications.....</b>	<b>35</b>
A.1 AC Line Current Draw and Thermal Dissipation Specifications.....	35
A.2 DMA16301 Audio Specifications .....	37
A.3 DMA32300, DMA24300, and DMA16300 Audio Specifications .....	38
A.4 Physical Specifications .....	38
<b>Appendix B Fuse Information.....</b>	<b>39</b>
B.1 Fuses .....	39

---

---

# Introduction

The Dolby® Multichannel Amplifier is an advanced high-density amplifier in a compact 4U rackmount chassis. The Class D amplification topology is designed to deliver high-performance audio quality on every channel.

The Dolby Multichannel Amplifier is designed for reliability. It includes a custom-built power supply with built-in redundancy, power sharing, operational monitoring, and fault detection. The power supply design enables the system to operate from a 100 to 240 VAC, 20 amp service without tripping the AC mains circuit breaker. The Dolby Multichannel Amplifier automatically detects maximum and net power usage and certain operational and environmental conditions, and adjusts channel gains based on power supply conditions, load conditions, and fault conditions.

The Dolby Multichannel Amplifier receives digital audio through the Dolby Atmos® Connect bitstream interface, which is included on Dolby products, such as the Dolby Atmos Cinema Processor CP850 and the Dolby Integrated Media Server IMS3000 (product model CID1002). In addition, it can also receive digital audio from a Dolby CP750 or other audio processors via a Yamaha Tio1608-D analog to digital converter. For information on this type of configuration, go to <https://www.dolbycustomer.com> and download the *Dolby CP750 7.1 audio for the Dolby Multichannel Amplifier manual*.

You can also interconnect additional Dolby Multichannel Amplifier units to support more channels and can use the Dolby Multichannel Amplifier with the CP850 analog outputs and Dolby Atmos Interface DAC3202s (to provide audio to amplifiers with analog inputs). To connect more than three amplifiers and/or three DAC3202s, you must use a switch. You cannot use the Dolby Multichannel Amplifier with Dolby Atmos Interface DAC3201s, as a different Dolby Atmos Connect protocol is used on these devices.

The Dolby Multichannel Amplifier currently ships in three configurations: 16-channel version (DMA16301 with CAT1433 high-powered amplifier cards), and 24-channel (DMA24300) and 32-channel (DMA32300) versions with CAT1422 lower-powered amplifier cards. The DMA16300 with CAT1422 cards is no longer available.

## 1.1 Dolby Multichannel Amplifier Front Panel

Figure 1-1 shows the Dolby Multichannel Amplifier front-panel components.



**Figure 1-1** Dolby Multichannel Amplifier Front Panel

Following is a description of the Dolby Multichannel Amplifier front-panel components.

### 1.1.1 LED Channel and System Status

The front-panel LEDs specify whether audio is present on the amplifier outputs of the various channels. These LEDs illuminate faintly in blue if no signal is present and illuminate brightly in blue if a signal is present. The LED indicators also alert you to various system states or if there is a problem with the amplifier.

Following are descriptions of the Dolby Multichannel Amplifier LED behavior for the various states:

- **Off mode:** None of the channel LEDs are illuminated. The power button illuminates in yellow.
- **Booting:** The signal LEDs begin illuminating in blue, from left to right. When all of the LEDs are lit, the system indicates that the booting process is complete by briefly illuminating the LEDs in white.
- **Channel clipping:** If the Dolby Multichannel Amplifier receives an excessive signal and is overdriven, the affected channel or channels may clip, which may be audible in the auditorium. Clipping is indicated when the signal LEDs illuminate in full white, for as long as the clipping occurs. Clipping indicators are also displayed in the **Status** screen. (See [Section 3.2.1](#).)
- **Channel shut down:** If there is a problem with the Dolby Multichannel Amplifier, wiring, or speakers, the unit may disable the affected channel or channels. The front-panel LEDs illuminate in red from the outer edges and meet in the center. After the LEDs illuminate in red, the affected channel LEDs blink red/yellow/red, and then the initial red LED sequence repeats. (For more information on the system status, see [Section 3.2.1](#).)
- **Shutdown mode due to hardware fault:** If the Dolby Multichannel Amplifier detects a critical problem and cannot compensate, all of the red LEDs slowly illuminate on and off. In such a case, disconnect power from the unit and wait two minutes. Then power up the unit. You may need to check the **Status** screen for additional information regarding this fault (see [Section 3.2.1](#)).
- **Normal shutdown:** When the Dolby Multichannel Amplifier is shutting down to off mode, the blue LEDs slowly illuminate on and off. Once the system is in off mode, the only indication is the illuminated power button.

### 1.1.2 Power Button

Press the power button to turn the Dolby Multichannel Amplifier on, and press and hold the power button for a few seconds to turn the unit off.

Following are descriptions of the power button LED behavior for the various states:

- **No illumination:** Disconnected mode. No AC power.
- **Solid yellow:** Off mode. System is plugged in, but not powered on.
- **Flashing white:** System is booting (typically occurs after pressing power button).
- **Solid blue:** System has booted.
- **Flashing blue:** System is booting or shutting down.
- **Solid red:** A critical power or thermal fault has occurred. There is no audio output.

If a fault has occurred, momentarily pressing the button clears the fault.

### 1.1.3 USB Port

This port provides you with the capability of performing alternative maintenance procedures when you insert a USB drive, as described in [Alternative Maintenance Procedures](#). It flashes in blue to indicate activity on this port.

## 1.2 Dolby Multichannel Amplifier Rear Panel

Figure 1-2 shows the DMA32300 rear-panel components.

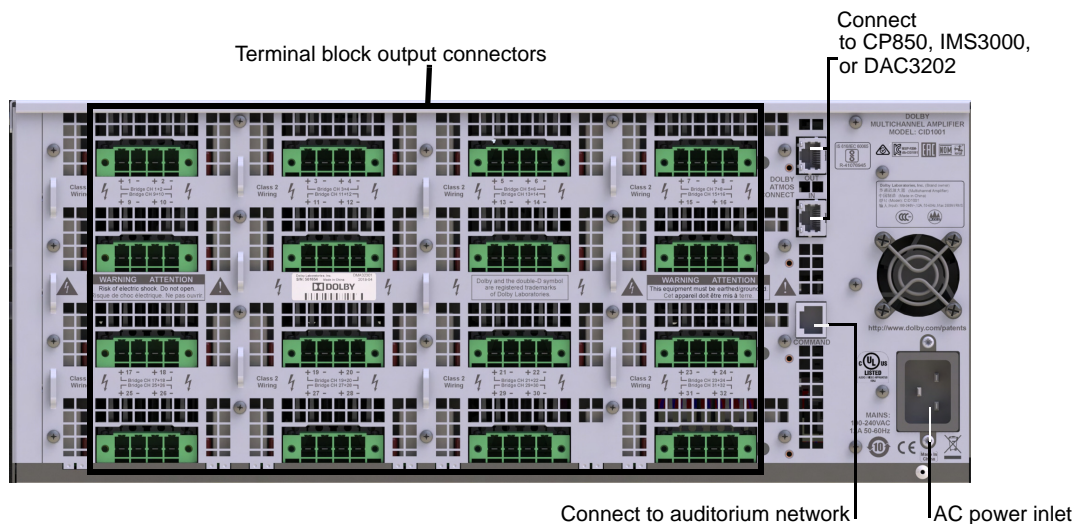

Figure 1-2 DMA32300 Rear Panel

Following is a description of the Dolby Multichannel Amplifier rear-panel components.

### 1.2.1 AC Mains Power Inlet

Connect the provided AC line cord (100 to 240 VAC) that is correct for your region to this port. This is an IEC 320-C20 20 A AC power inlet.

### 1.2.2 Dolby Atmos Connect In/Out RJ45 Ports

Use these ports to connect to the CP850, IMS3000, or DAC3202, as described in [Section 2.4](#) and [Section 2.5](#).

### 1.2.3 Command (Com) RJ45 Port

Use this port to connect to the auditorium network switch. You perform all setups, control, and monitoring of a Dolby Multichannel Amplifier through this connection.

### 1.2.4 Terminal Block Connectors

The Dolby Multichannel Amplifier has an array of two-channel terminal block connectors, depending upon the configuration. Each connector is labeled on the rear panel, which indicates its audio output channels, respective pinouts, and bridging information.

---

---

---

# Installing the Dolby Multichannel Amplifier

This chapter is for qualified installers and provides step-by-step instructions for installing the Dolby® Multichannel Amplifier. It covers:

- [Rack-Mounting Instructions](#)
- [Connecting AC Power](#)
- [Connecting Audio Input](#)
- [Connecting a Single Dolby Multichannel Amplifier](#)
- [Connecting Two Dolby Multichannel Amplifiers](#)
- [Connecting the Output Channels to the Speakers](#)

Depending on your region, you should have received the appropriate accessory kit for your Dolby Multichannel Amplifier:

- DMA-ACC-US is for the United States and Canada.
- DMA-ACC-CN is for China.
- DMA-ACC-ROW is for the rest of the world.

These kits include the required AC line cord, terminal block output connectors (for the amplifier outputs), a printed quick start guide, cable management bars, and rack brackets (required for racks with prethreaded or drilled holes).

## 2.1 Rack-Mounting Instructions

You need to rack mount Dolby Multichannel Amplifier units in a 4U rackspace. You can order the optional quick-release rail kits for your amplifiers, depending on your requirements. These rails are designed for installation into racks with square holes.

- CAT1240 is the short rail kit for racks that are 9 to 26 inches (23 to 66 cm) deep.
- CAT1140 is the long rail kit for racks that are 26 to 38 inches (66 to 97 cm) deep.

The Dolby Multichannel Amplifier is 22 inches (56 cm) inches deep, but we recommend a rack that is at least 32 inches (81 cm) deep so that you can install the required cables and maintain proper airflow. In accordance with modern IT equipment conventions, the Dolby Multichannel Amplifier intakes air at the front panel and exhausts out the back of the unit.

You should inspect the Dolby Multichannel Amplifier and its shipping package and contact Dolby immediately if you find any damage.

Identify a suitable location for the rack unit that will hold the Dolby Multichannel Amplifier. It should be situated in a clean, dust-free area that is well ventilated. Avoid areas where heat, electrical noise, and electromagnetic fields are generated. You will also need to place it near a grounded power outlet. Read all of the precautions listed in [Section 2.1.1](#).

## 2.1.1 Preparing for Setup

Leave at least 25 inches (63 cm) clearance in front of the rack and approximately 30 inches (76 cm) of clearance in the back of the rack to allow for sufficient air flow and access for servicing.



### Rack Precautions

Be sure to take these precautions when installing the rack:

- Ensure that the leveling jacks on the bottom of the rack are fully extended to the floor with the full weight of the rack resting on them.
- In a single-rack installation, attach stabilizers to the rack.
- In multiple-rack installations, couple the racks together.
- Before extending a component from the rack, be sure the rack is stable.

Extend only one component in a rack at a time; extending two or more simultaneously may cause the rack to become unstable.



### General Component Precautions

Be sure to take these precautions when installing all components in the rack:

- Review the electrical and general safety precautions.
- Identify the placement of each component in the rack before you install the rails.
- Install the heaviest rack components on the bottom of the rack first, and then work up to the lightest.
- Close all panels, all components, and rack door (if present) when not servicing, to maintain proper cooling.



### Rack-Mounting Considerations

Be sure to consider the following when installing the rack.

#### Ambient Operating Temperature

If installed in a closed or multiunit rack assembly, the ambient operating temperature of the rack environment may be greater than the ambient temperature of the room. Therefore, consideration should be given to installing the equipment in an environment compatible with the manufacturer's maximum rated ambient temperature.

#### Airflow

Equipment should be mounted into a rack so that the amount of airflow required for safe operation is not compromised. The Dolby Multichannel Amplifier airflow is from front to back.

#### Mechanical Loading

Equipment should be mounted into a rack so that a hazardous condition does not arise due to uneven mechanical loading.

## Circuit Overloading

You must connect the Dolby Multichannel Amplifier to a dedicated circuit. Be sure to consider the connection of the equipment to the power supply circuitry and the effect that any possible overloading of circuits might have on over-current protection and power supply wiring. Appropriate consideration of equipment name-plate ratings should be used when addressing this concern.

## Reliable Ground

A reliable ground must be maintained at all times. To ensure this, the rack itself should be grounded. Particular attention should be given to power supply connections other than the direct connections to the branch circuit (such as the use of power strips).

### 2.1.2 Installing the Dolby Multichannel Amplifier in a Rack Using the Long or Short Rails

Following are instructions for installing the Dolby Multichannel Amplifier into its rack using the long or short rails. There are several types of racks available, which may require slight variations in the installation procedure. You should also refer to the installation instructions provided with your rack.



---

**Note:** If your rack does not have square holes, you will need to install the adapter bracket that is included in your accessory kit (along with the AC line cord).

---

Rail kits are shipped separately from the accessory kits. There are two rail assemblies provided for the rails. Each assembly consists of two sections, an inner fixed chassis rail that secures directly to the Dolby Multichannel Amplifier and an outer fixed rack rail that secures directly to the rack itself.

To install the optional quick-release rails:

1. Separate the inner and outer rails on each assembly (refer to [Figure 2-1](#)):
  - Extend the rail assembly by pulling it outward.
  - Press the quick-release tab.
  - Separate the inner rail extension from the outer rail assembly.

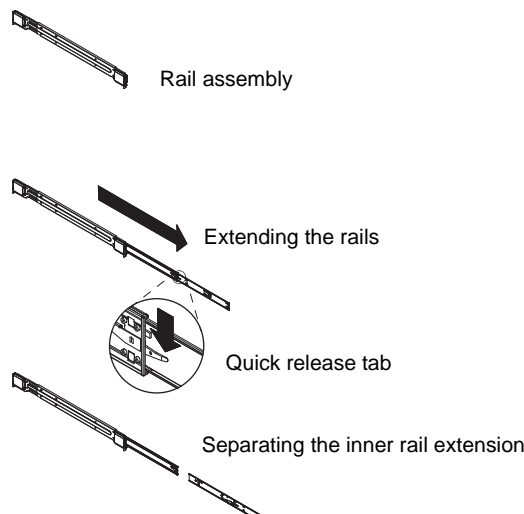

**Figure 2-1** Separating the Small Quick-Release Rails

2. Install the inner rail extensions, as shown in [Figure 2-2](#):
  - Place the inner rack extensions on each side of the Dolby Multichannel Amplifier chassis, aligning the hooks of the Dolby Multichannel Amplifier chassis with the rail extension holes.
  - Be sure each extension faces outward just like the inner rail.
  - Slide the first extension toward the front of the Dolby Multichannel Amplifier chassis.
  - Secure the inner rail to the Dolby Multichannel Amplifier chassis with the two provided M4 flat-head screws, as shown in [Figure 2-2](#). Repeat these steps for the other inner rail.

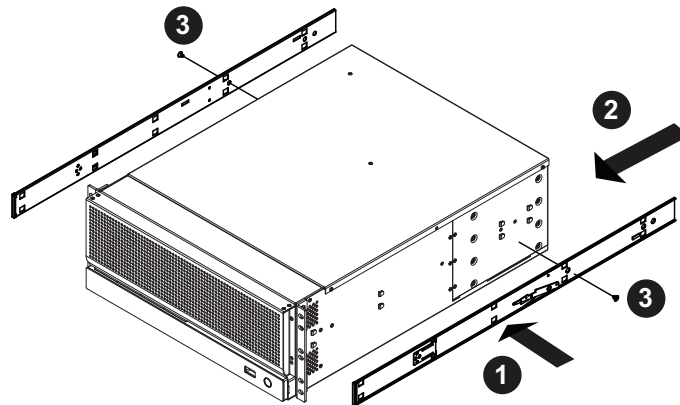

**Figure 2-2** Installing the Inner Rail Extensions on the Small Rails

3. Assemble the outer rack rails, which attach to the rack:
  - Secure the back end of the outer rail to the rack, using the provided screws.
  - To retract the smaller outer rail, press the button where the two outer rails join.
  - Hang the rail hooks on the rack holes, and if desired, use the provided screws to secure the front of the outer rail to the rack.
  - Repeat steps 1–3 for the other outer rail.

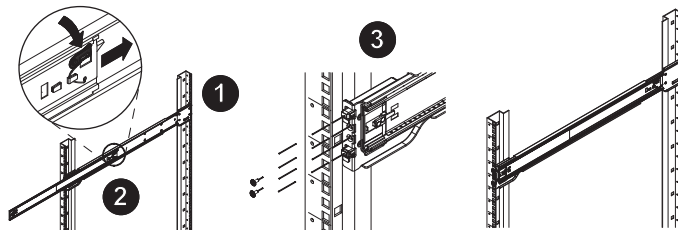

**Figure 2-3** Assembling the Outer Small Rails

4. Install the Dolby Multichannel Amplifier into the rack, as shown in the following figure:
  - Confirm that the inner and outer rails are installed on the rack.
  - Extend the outer rails.
  - Align the inner rails on the Dolby Multichannel Amplifier with the outer rails on the rack.
  - Slide the inner rails into the outer rails, maintaining equal pressure on both sides. When the Dolby Multichannel Amplifier is completely inserted into the rack, it should click into the locked position.

- Insert and tighten the 10-32 rack screws in the center hole locations to secure the Dolby Multichannel Amplifier to the rack.
- Rail brackets (included with the regional accessory kits) are required for racks with prethreaded or drilled holes.

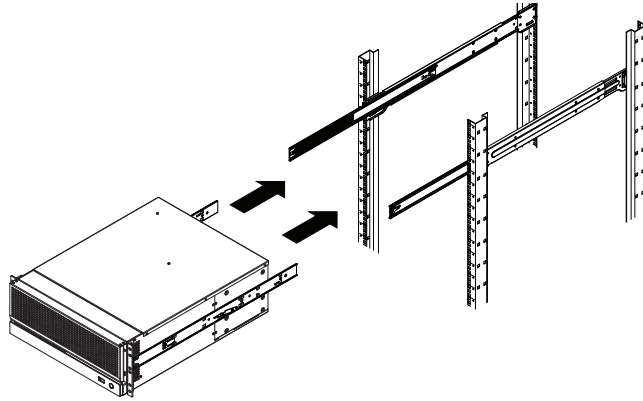

**Figure 2-4** Installing the Dolby Multichannel Amplifier in the Rack Using the Small Rails

5. Connect all cables and configure the system, as described in the following sections. Two cable management bars (Part Number 6201910) are shipped with the regional accessory kits. These bars are slotted for cable ties and attach to the rear side of your rack to support the weight of the cables. We recommend that you minimize any tension on the terminal block connectors when using large-gauge cables.



**Figure 2-5** Cable Management Bars

### 2.1.3 Additional Requirements

The Dolby Multichannel Amplifier vents from front to back. Be sure to provide proper clearance and unobstructed airflow. Do not install the units above heat-generating equipment. For CP850 configurations, the Dolby Multichannel Amplifier should be mounted in the same rack as the CP850 to avoid potential problems with ground loops, radiated interference, and so on.



**Note:** Follow all local codes and regulations covering electrical wiring.

## 2.2 Connecting AC Power

Following are the Dolby Multichannel Amplifier AC input requirements:

- AC voltage: 100 to 240 VAC
- Type of connection: Dedicated breaker circuit

Breaker current: 15 or 20 amp circuit. You must configure this parameter in the Dolby Multichannel Amplifier web client (See [Section 3.2.4](#)). The web client default configuration is 15 amps, so you must change this setting to 20 amps if a 20 amp breaker is used; otherwise, the unit limits prematurely and does not utilize the full AC input capability.

## 2.3 Connecting Audio Input

You can connect a Dolby Multichannel Amplifier in different configurations, depending upon your requirements. Each Dolby Multichannel Amplifier receives digital audio and outputs amplified audio based on the number and type of amplifier cards that are installed in the unit.



**Note:** If more channels are required, you can add additional units for amplified channels or Dolby DAC3202s for analog (nonamplified) channels. In either case, you cannot combine more than three of these devices unless you use a switch. For more information on switch configurations, see [Section 2.5.1](#).



**Note:** You cannot combine the Dolby Multichannel Amplifier or DAC3202 outputs with a Dolby Atmos® Interface DAC3201. The DAC3201 uses a different protocol that is not supported by the other devices.

The following figure shows some of the different configurations for interconnecting Dolby audio processors that provide digital outputs. (For audio processors with no digital outputs, see the separate *Dolby CP750 7.1 audio for the Dolby Multichannel Amplifier manual*.)

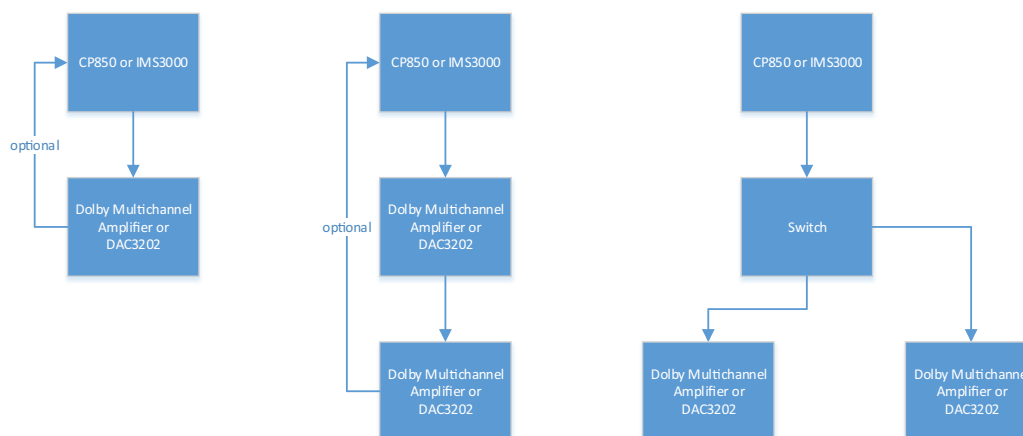

**Figure 2-6** Dolby Multichannel Amplifier Configurations



**Note:** If your installation still requires more channels, you can also utilize the CP850 analog outputs or the IMS3000 digital outputs.

## 2.4 Connecting a Single Dolby Multichannel Amplifier

To connect a single Dolby Multichannel Amplifier (to output up to 32 channels) using a Dolby Atmos Cinema Processor CP850 or a Dolby IMS3000 (with Dolby Atmos):

1. Use a shielded Cat5e or greater cable to connect the Dolby Multichannel Amplifier **COMMAND** port to the auditorium network switch.
2. Use a second shielded Cat5e or greater cable to connect the CP850 or IMS3000 **DOLBY ATMOS CONNECT OUT** port to the **DOLBY ATMOS CONNECT IN** port on the Dolby Multichannel Amplifier rear panel.
3. Use a third shielded Cat5e or greater cable to connect the CP850 or IMS3000 **DOLBY ATMOS CONNECT IN** port to the **DOLBY ATMOS CONNECT OUT** port on the Dolby Multichannel Amplifier.

Connecting to a CP850

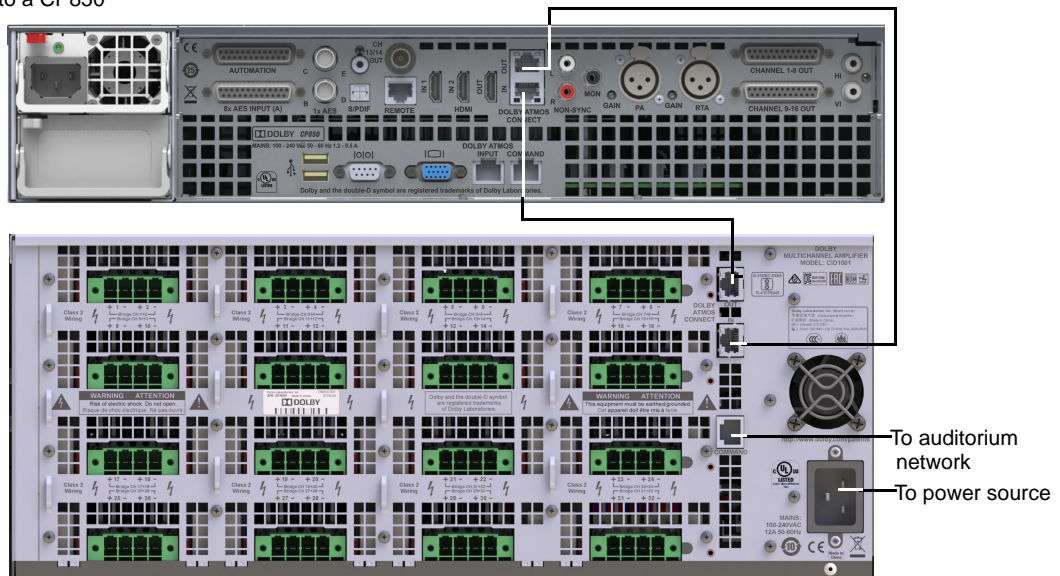

Connecting to an IMS3000

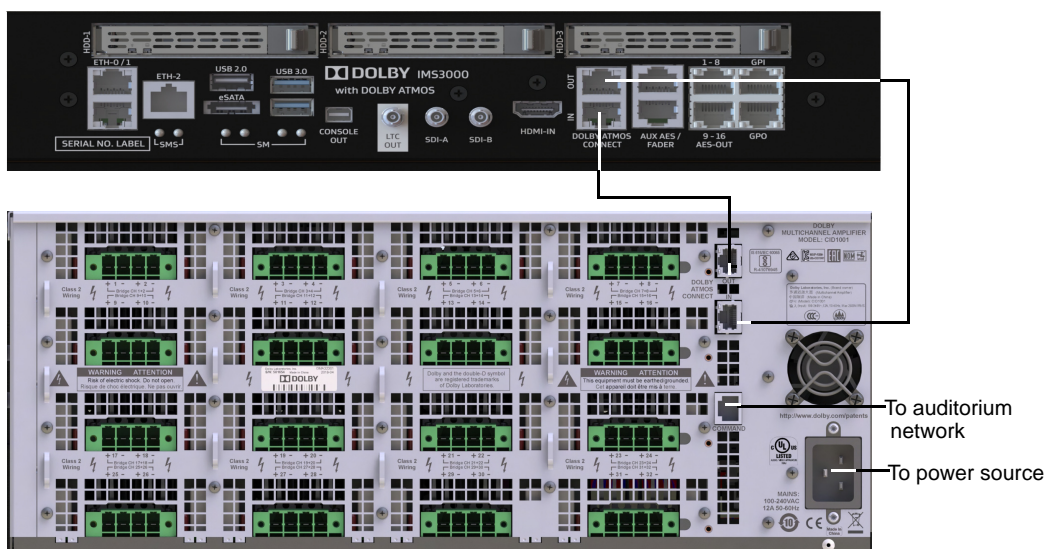
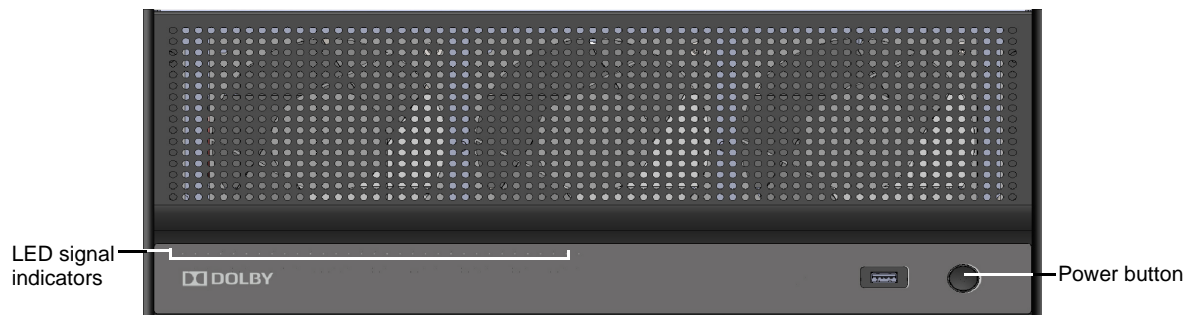

Figure 2-7 Connecting a Single Dolby Multichannel Amplifier to a CP850 or an IMS3000

4. Plug the unit into any dedicated electrical circuit with a line input voltage from 100–240 VAC, press the power button to boot up the unit, and then connect your computer to the auditorium switch.



**Figure 2-8** Dolby Multichannel Amplifier Front Panel



**Note:** The Dolby Multichannel Amplifier boots up in approximately 3.5 minutes. During start-up, the power button on the Dolby Multichannel Amplifier front panel flashes on and off in white and the signal indicators illuminate in blue from left to right. When the boot process is complete, the power button and the LED signal indicators (for each channel) illuminate in blue.

5. Configure your computer IP address to communicate with the Dolby Multichannel Amplifier default IP address (192.168.1.143) on the **COMMAND** port. We recommend that you enter an IP address above 192.168.1.150 and below 192.168.1.254, with a subnet of 255.255.255.0.
6. Open your web browser, and enter the Dolby Multichannel Amplifier **COMMAND** port default IP address 192.168.1.143 to display the web client user control screen. (Currently, we recommend only the Google™ Chrome™ browser.)
7. Under the **Command** section of the **Network** tab, click **Manual** for **IP configuration**. We recommend that you change the **IP address**, **Netmask**, and **Gateway** settings to work with your IP schema by clicking in the respective fields, making the required entries, and clicking **Apply**. When prompted for credentials, the default password is *password*.

If you are using the Dolby default IP scheme, we recommend that you change the third octet of the default IP address to match your auditorium number and the fourth octet to 143. This will be 192.168.x.143, where x = auditorium number.

## 2.5 Connecting Two Dolby Multichannel Amplifiers

To connect two Dolby Multichannel Amplifier units (to output up to 64 channels) using a Dolby Atmos Cinema Processor CP850 or a Dolby IMS3000 (with Dolby Atmos):

1. Connect the **COMMAND** port on each Dolby Multichannel Amplifier to the auditorium network switch.
2. Connect the CP850 or IMS3000 **DOLBY ATMOS CONNECT OUT** port to the **DOLBY ATMOS CONNECT IN** port on the first Dolby Multichannel Amplifier rear panel.
3. Connect the **DOLBY ATMOS CONNECT OUT** port on the first Dolby Multichannel Amplifier to the **DOLBY ATMOS CONNECT IN** port on the second Dolby Multichannel Amplifier.
4. Connect the CP850 or IMS3000 **DOLBY ATMOS CONNECT IN** port to the **DOLBY ATMOS CONNECT OUT** port on the second Dolby Multichannel Amplifier.

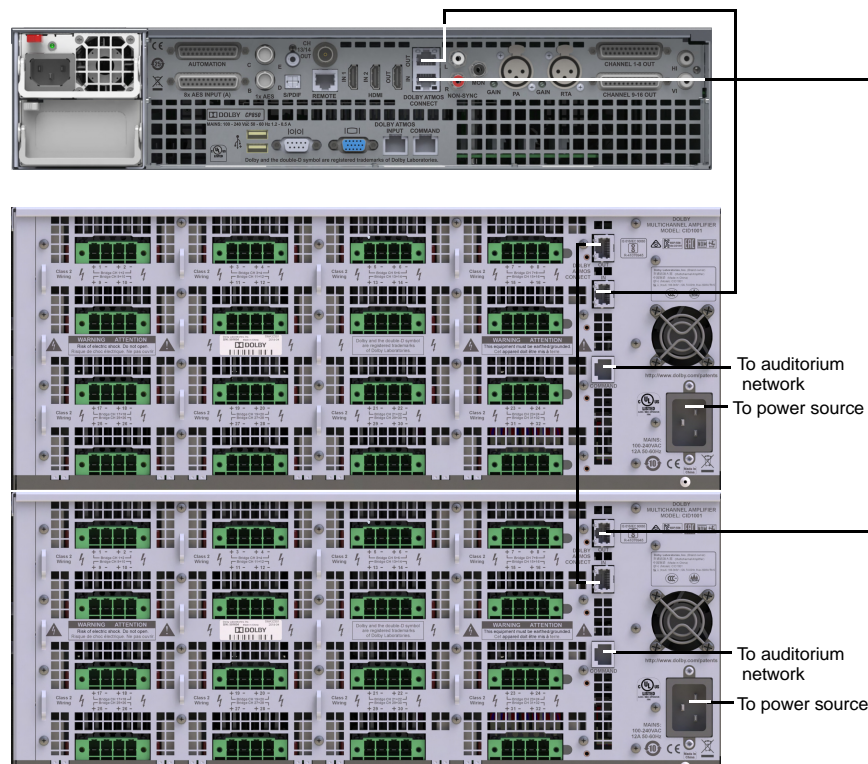

**Figure 2-9** Connecting Two Dolby Multichannel Amplifiers to a CP850



**Note:** Be sure to use shielded Cat5e or greater cables for the input/output connections.

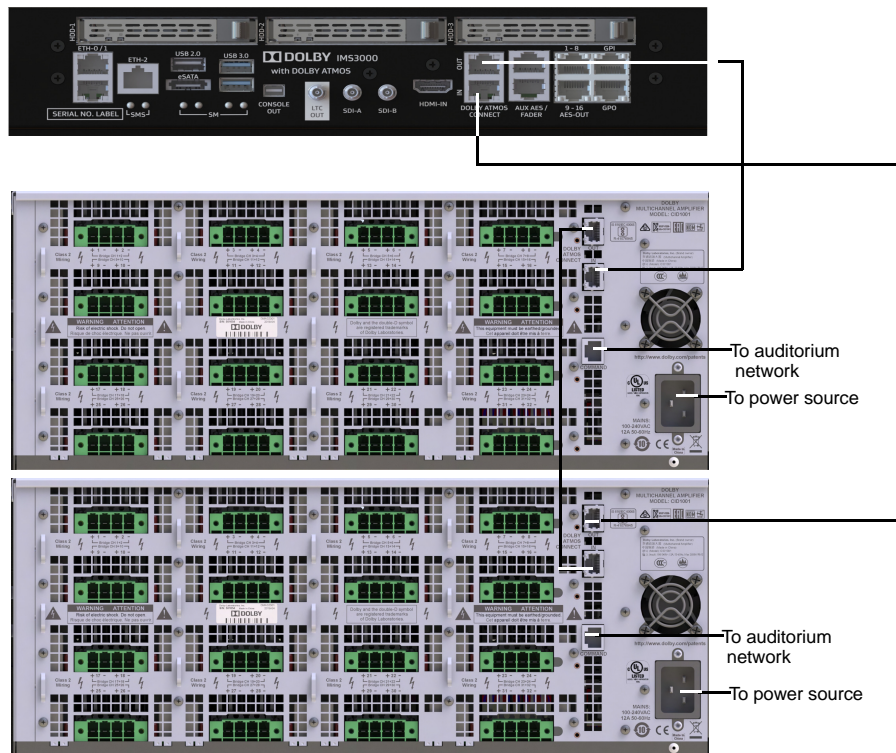

**Figure 2-10** Connecting Two Dolby Multichannel Amplifiers to an IMS3000

5. Refer to steps 6 and 7 in [Section 2.4](#) for connecting a single unit, and apply these to the second unit.
6. Plug the second Dolby Multichannel Amplifier into a dedicated electrical circuit with a line input voltage from 100 to 240 VAC. If you are using the Dolby default IP scheme, we recommend that you change the fourth octet of the second unit to 144, which results in an IP address of 192.168.x.144 for the second channel group, where x = auditorium number. (The previously configured IP address for the first unit is 192.168.x.143 for the first channel group.)
7. If a third Dolby Multichannel Amplifier is required, and you are using the Dolby default IP scheme, we recommend that you change the fourth octet of the second unit to 145, which results in an IP address of 192.168.x.145 for the third channel group, where x = auditorium number. (The previously configured IP address for the second unit is 192.168.x.144 for the second channel group.)
8. Click the **Dolby Atmos Connect** tab, and configure the channels for the first, second, or third unit.



**Note:** If more channels are required, you can add additional units for amplified channels or Dolby DAC3202s for analog (nonamplified) channels. In either case, you cannot interconnect more than three of these devices unless you use a switch. For detailed information on using a switch, see [Section 2.5.1](#).



**Note:** Be sure to use shielded Cat5e or greater cables for the input/output connections.

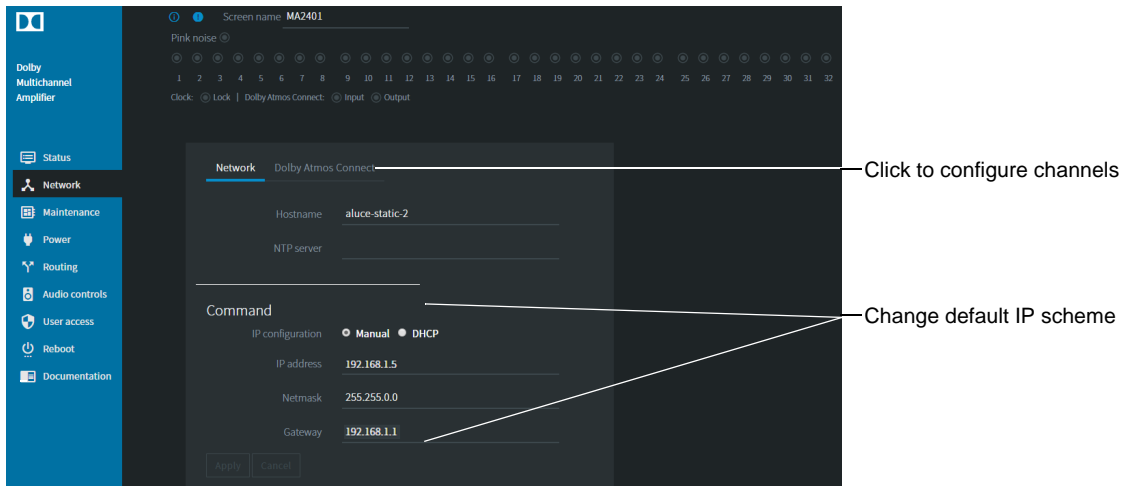

Figure 2-11 Configure Channels and Change Default IP Scheme

## 2.5.1 Using Dolby Multichannel Amplifiers or DAC3202s with a Switch

We recommend connecting three or more devices on the Dolby Atmos Connect network (AES67 protocol) through a network switch. However, you must connect more than three devices using a switch. This ensures that each of the units receives the same timing messages to keep the audio synchronized.

1. Connect the **Dolby Atmos Connect OUT** port from the Dolby CP850 or IMS3000 to the switch.
2. Connect the **Dolby Atmos Connect IN** ports on the Dolby Multichannel Amplifiers and/or Dolby DAC3202s to the same switch. No loop-back cabling is required.

Following are the desired switch specifications for interconnecting four or more devices:

- For a dedicated network, we recommend a switch that provides Gigabit speed to create a star-topology audio network.
- For a nondedicated network, we recommend a managed switch that supports:
  - Gigabit speed
  - DiffServ Quality of Service (QoS) with strict priority and four queues

## 2.6 Connecting the Output Channels to the Speakers

The Dolby Multichannel Amplifier supports output channels in both normal and bridge mode.

In normal mode:

- For DMA16301 systems with the high-power amplifier cards, each channel can provide up to 300 watts of audio power into an 8 ohm speaker, up to 600 watts into a 4 ohm speaker, and up to 600 watts into a 2 ohm speaker.
- For DMA24300 and DMA32300 systems with the lower-powered amplifier cards, each channel can provide up to 300 watts of audio power into an 8 ohm speaker or 4 ohm speaker.

In bridge mode:

- For DMA16301 systems with the high-power amplifier cards, you can bridge a channel pair to supply up to 1100 watts into an 8 ohm or 4 ohm speaker. Bridging on these cards is not supported on 2 ohm speakers.
- For DMA24300 and DMA32300 systems with the lower-powered amplifier cards, you can bridge a channel pair to supply up to 600 watts. Bridging on these cards is supported only on 8 ohm speakers.



**Note:** For DMA24300 and DMA32300 systems with version 1.0.xx software, bridging channels results in a loss of the even numbered output for use on other speakers. For example, when you bridge channels 1 and 2, you cannot use channel 2. Upgrading to version 2.0.x.x software or higher provides improved routing options that allow you to use the even numbered channels.

To determine the number and type of amplifier cards installed in a Dolby Multichannel Amplifier, click the system info button at the top of the web client user-control screen.

System	2.0.0.12-4502224		
Hardware	1		
FPGA	640		
Power Supply Software	2.2		
Power Supply Board	6		
Front Panel	0.0		
Slot	Type	FPGA	Board
1	CAT1433	97	1.0
2	CAT1433	97	1.0
3	-	-	-
4	-	-	-

**Figure 2-12** Click Info Button to Display System Information

The Dolby Multichannel Amplifier outputs are arranged in terminal blocks. In normal mode, each Dolby Multichannel Amplifier terminal block supports two loudspeaker terminations. In bridge mode, each terminal block supports a single loudspeaker termination. In either mode, you connect a speaker using two wires. One wire is positive (+), and the other wire is negative (-).

The speaker wires interface to the Dolby Multichannel Amplifier with a mating four-way terminal block plug, as shown in the following figures. Sixteen of these plugs are included in your accessory kit. You secure these plugs to each side of the terminal blocks with the provided screws. These plugs can accept up to 8 AWG stranded speaker wire with insulation stripped back 6-7 mm. When connected, there should be no bare wires exposed on the connector. You should secure the wires into the connector with a torque rating of approximately 7 in-lb.



**Warning:** Disconnect the AC mains power prior to making any connections. When the AC power is on, there may be dangerous voltage at the terminal blocks on the Dolby Multichannel Amplifier rear panel. Do not touch these contacts. Be sure to use Class-2 wiring for your connections.

### 2.6.1 Connecting Channels in Normal Mode

To connect a channel pair on a terminal block to a speaker in normal mode:

1. Locate the two connectors on the left of the terminal block plug.
2. Connect the positive (+) output of the amplifier to the positive (+) input terminal of a speaker.
3. Connect the negative (-) output of the amplifier to the negative (-) input terminal on the same speaker. (See [Figure 2-13](#).)

To connect a second channel pair on the terminal block to a speaker in normal mode:

1. Locate the two connectors on the right side of the terminal block plug.
2. Connect the positive (+) output of the amplifier to the positive (+) input terminal of a speaker.
3. Connect the negative (-) output of the amplifier to the negative (-) input terminal on the same speaker.

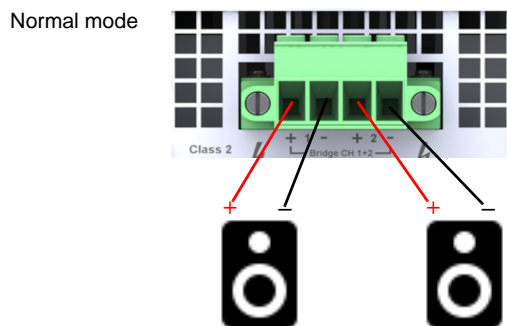

**Figure 2-13** Connecting Channels from the Terminal Block to Speakers in Normal Mode



**Note:** Be sure to use appropriate wire gauge, based upon loudspeaker impedance and the distance between the Dolby Multichannel Amplifier and the loudspeaker. The rear panel output terminal blocks are designed to accept up to 8 gauge wire.

## 2.6.2 Connecting Channels in Bridge Mode



**Note:** For earlier Dolby Multichannel Amplifiers with version 1.x.x software installed, bridging channels results in a loss of the even numbered output for use on other speakers. For example, when you bridge channels 1 and 2, you cannot use channel 2. Upgrading to version 2.x.x software or higher provides improved routing options that allow you to use the even numbered channels.



**Warning:** Disconnect the AC mains power prior to making any connections. When the AC power is on, there may be dangerous voltage at the terminal blocks on the Dolby Multichannel Amplifier rear panel. Do not touch these contacts. Be sure to use Class-2 wiring for your connections.

To connect two channels in bridge mode, use the connectors that are furthest left and furthest right:

1. Connect the positive (+) output on the first channel (left terminal of the terminal block plug) to the positive (+) input on a speaker.
2. Connect the negative (-) output on the second channel (right terminal of the terminal block plug) to the negative (-) input on the same speaker.

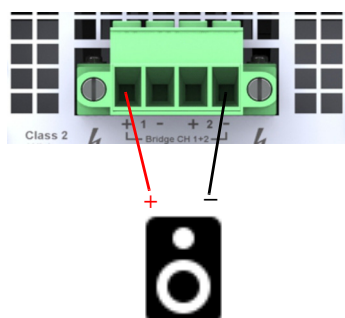

**Figure 2-14** Connecting Channels from the Terminal Block to a Speaker in Bridge Mode

For bridge mode, you must configure the channel pair using the web client. (See [Section 3.2.4.](#))



**Note:** For the high-powered CAT1433 amplifier cards, when configuring the Dolby Multichannel Amplifier in bridged mode, be sure that the rated loudspeaker impedance is no less than 4 ohms. For the lower-powered CAT1422 cards, in bridged mode, be sure that the rated loudspeaker impedance is no less than 8 ohms.



**Note:** Be sure to use appropriate wire gauge, based upon loudspeaker impedance and the distance between the Dolby Multichannel Amplifier and the loudspeaker. The rear-panel output terminal blocks are designed to accept up to 8-gauge wire.

---

## Using the Dolby Multichannel Amplifier

After installing one or more Dolby® Multichannel Amplifiers in your auditorium network, as described in [Chapter 2](#), you can configure and operate your system, as described on the following pages. This chapter covers the following:

- [Connecting to the Dolby Multichannel Amplifier](#)
- [Navigation Bar](#)
  - [Status](#)
  - [Network](#)
  - [Maintenance](#)
  - [Power](#)
  - [Routing](#)
  - [Audio Controls](#)
  - [User Access](#)
  - [Reboot](#)
  - [Documentation](#)

### 3.1 Connecting to the Dolby Multichannel Amplifier

To connect to a Dolby Multichannel Amplifier, open your web browser, and enter the Dolby Multichannel Amplifier **Command** port IP address to display the web client user-control screen. The default IP address is 192.168.1.143. (Currently, we recommend only the Google™ Chrome™ browser.)

The web-client user-control screen appears and the **Status** tab is active, as indicated by its black highlighting in the navigation bar at the left side of the screen.

The screen name (which is editable) and the audio and clock indicators appear at the top of the screen. The **clock:lock** LED illuminates in blue when the Dolby Multichannel Amplifier locks to a valid AES67 audio clock signal from a CP850, IMS3000, or other device. The **Dolby Atmos Connect** port LEDs illuminate in blue if the connections to a CP850, IMS3000, or other device are correct, and the **Dolby Atmos Connect** parameters are properly configured (see [Section 3.2.2](#)). You can click the respective buttons to access system information and error messages. These areas of the web client, along with the navigation bar, appear in all Dolby Multichannel Amplifier screens, which are described in the following sections.

For a full display of the **Status** screen, see [Section 3.2.1](#).

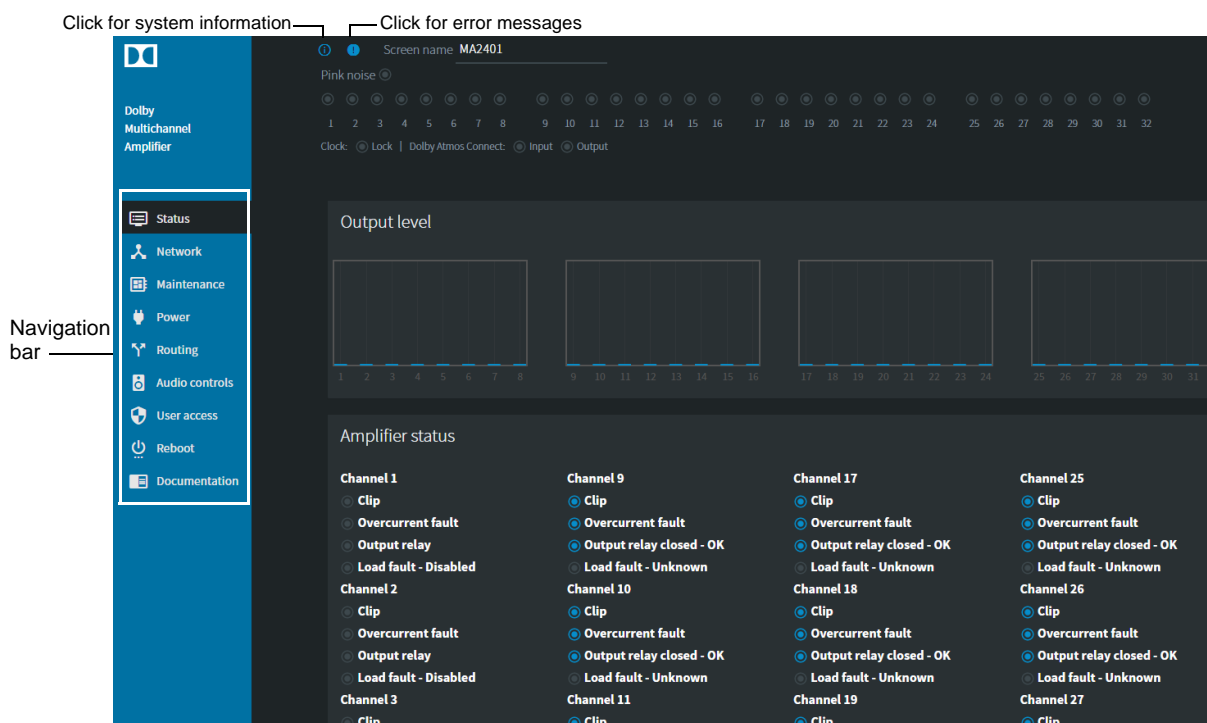

Figure 3-1 Web Client Status Screen

## 3.2 Navigation Bar

The Dolby Multichannel Amplifier navigation bar provides access to the Dolby Multichannel Amplifier **Status, Network, Maintenance, Power, Routing, Audio controls, and User access** parameters. In addition, you can reboot the system and access user documentation from the navigation bar. Click the desired menu option to display the corresponding screen. To reconfigure most of these parameters and perform other functions, you need to enter your password at the prompt. (The default password is *password*.)

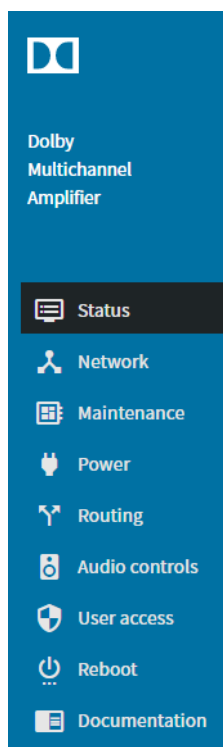

Figure 3-2 Navigation Bar

### 3.2.1 Status

When you click **Status** in the navigation bar, you can check the **Amplifier, Fans, Temperature, and Power Supply** status, as indicated by the respective blue (normal) or red (fault) illumination.



Figure 3-3 Status Screen

## 3.2.2 Network

To configure the network parameters, click **Network** in the navigation bar. The network screen appears. In this screen, you can enter the host name and the Network Time Protocol (NTP) server settings. You can also configure the **COMMAND** port settings, as described in [Chapter 2](#). To reconfigure most of these settings, you need to enter your password at the prompt. (The default password is *password*.) After entering the desired settings, click the **Apply** button.

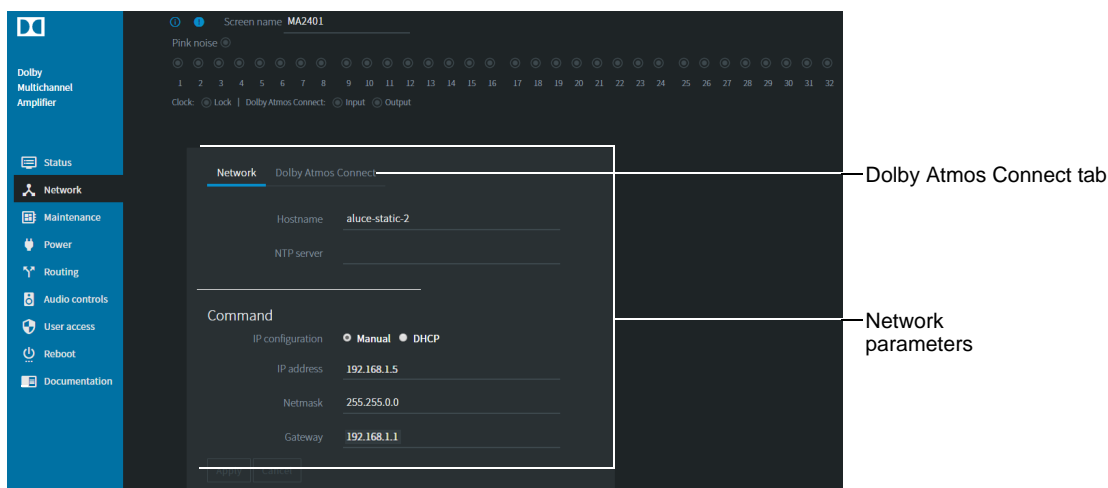

Figure 3-4 Network Screen

### Dolby Atmos Connect Parameters

To configure the Dolby Atmos Connect parameters, click the **Dolby Atmos Connect** tab in the network screen to specify the input and output configuration for the corresponding ports on the Dolby Multichannel Amplifier rear panel. After entering your settings, click **Apply** (or **Cancel** to undo).

This screen defaults to the **Manual Mode** input settings, which you can enter here, or exit by unchecking **Manual Mode** to display [Available Sessions Mode](#), as described later in this section. If you go to **Available Sessions** mode and then return to **Manual Mode**, you must click **Cancel** (or reenter the default PTP Time Protocol [**PTP domain number**] of **109**.) PTP is defined on the next page.

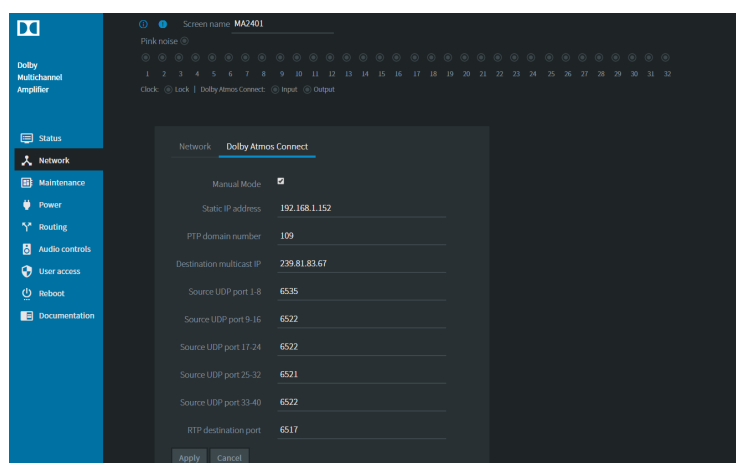

Figure 3-5 Dolby Atmos Connect Parameters

Following is a description of the Dolby Atmos Connect **Manual Mode** parameters. To change any of these settings, enter the required parameter in the respective field (or click in the corresponding box), and click the **Apply** button. To undo your changes, click the **Cancel** button.

### Static IP Address

In this field, you can change the default Dolby Atmos Connect static IP address.

### PTP Domain Number

PTP maintains the audio synchronization between the playback device and any connected devices within an auditorium, such as a Dolby Multichannel Amplifier or DAC3202. The default setting is **109**. If only one auditorium within a facility has a Dolby Multichannel Amplifier installed, we recommend that you retain this default value. If more than one auditorium is interconnected on the same network, you must enter unique PTP values for each auditorium. The PTP domain number in this field must match the PTP domain number in the CP850 or IMS3000 or another playback device.

### Destination Multicast IP

The multicast IP address is a logical identifier for a group of network hosts, which can simultaneously process audio frames on one or more destination systems. In such a case, the playback device multicasts digital audio to any downstream device (that is, Dolby Multichannel Amplifier or DAC3202). The multicast IP address in this field must match the multicast IP address in the CP850 or IMS3000.

### Source UDP Port

User Datagram Protocol (UDP) is an alternative communications protocol to Transmission Control Protocol (TCP). The system uses UDP to establish low-latency and loss-tolerating connections between applications. This allows for fast delivery of the audio signals to any connected devices. Both UDP and TCP run on top of the Internet Protocol (IP) and are sometimes referred to as UDP/IP or TCP/IP. Both protocols send short packets of data. UDP does not require confirmation by the sending device that packets were received.

UDP provides two services not provided by the IP layer. It provides port numbers to help distinguish different user requests and, optionally, a checksum capability to verify that the data arrived intact. The system relays audio for the different channels in an auditorium to specific port numbers to keep those channels separated. The source UDP port number in this field must match the source UDP port on the CP850 or IMS3000.

If you hover over these fields, you can enter the desired UDP settings for each channel bank by using the up/down arrows, as described next.

You can apply different channels to the source UDP port. When the source UDP port number matches the source UDP port number on the CP850 or IMS3000 (6518), the system applies digital channels 1–8 to the port:

- When you increase this number by one (6519), Dolby Atmos Connect channels 9–16 are applied to this port.
- When you increase the number by two (6520), Dolby Atmos Connect channels 17–24 are applied to this port.
- When you increase this number by three (6521), Dolby Atmos Connect channels 25–32 are applied to this port.

- When you increase this number by four (6522), Dolby Atmos Connect channels 33–40 are applied to this port.
- When you increase this number by five (6523), Dolby Atmos Connect channels 41–48 are applied to this port.
- When you increase this number by six (6524), Dolby Atmos Connect channels 49–56 are applied to this port.
- When you increase this number by seven (6525), Dolby Atmos Connect channels 57–64 are applied to this port.

## RTP Destination Port

The system uses Real-time Transport Protocol (RTP) for transporting audio over IP. The RTP destination port number in this field must match the RTP destination port on the CP850 or IMS3000.

## Available Sessions Mode

If you uncheck the **Manual Mode** box in the **Dolby Atmos Connect** screen, the **Available sessions** fields appear for input streams 1 through 5. In these fields, you can select from any input stream that is detected by the Dolby Multichannel Amplifier (for example, a Yamaha Tio1608-D input stream that converts the analog output from a Dolby CP750 [or other audio processor] to a digital input stream for use by the Dolby Multichannel Amplifier. For details on this type of configuration, see the separate *Dolby CP750 7.1 audio for the Dolby Multichannel Amplifier manual*.



**Note:** When you first enter **Available sessions** mode, the **PTP domain number** default setting is **0**. If you immediately return to **Manual Mode**, it remains **0** and you must reenter the default Manual mode PTP domain number of **109** if you need to work in Manual mode.

After selecting an available input stream, enter a static IP address. The default PTP domain number is **0**, which you should use for the Yamaha Tio1608-D input stream configuration. Click **Apply** to enter your settings or **Cancel** to undo.

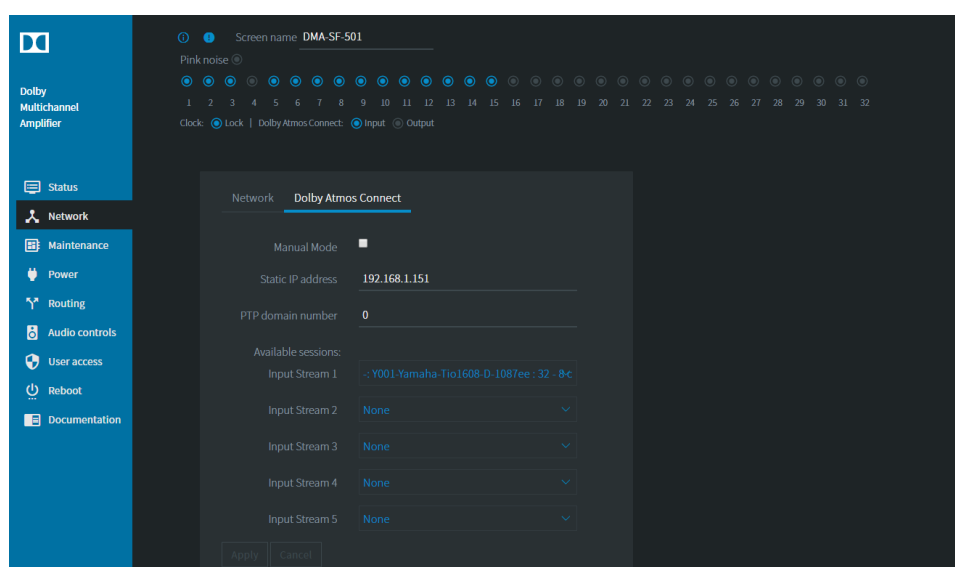

**Figure 3-6** Available Sessions Yamaha Tio1608-D Input Stream 1

### 3.2.3 Maintenance

To perform maintenance tasks, click **Maintenance** in the navigation bar.

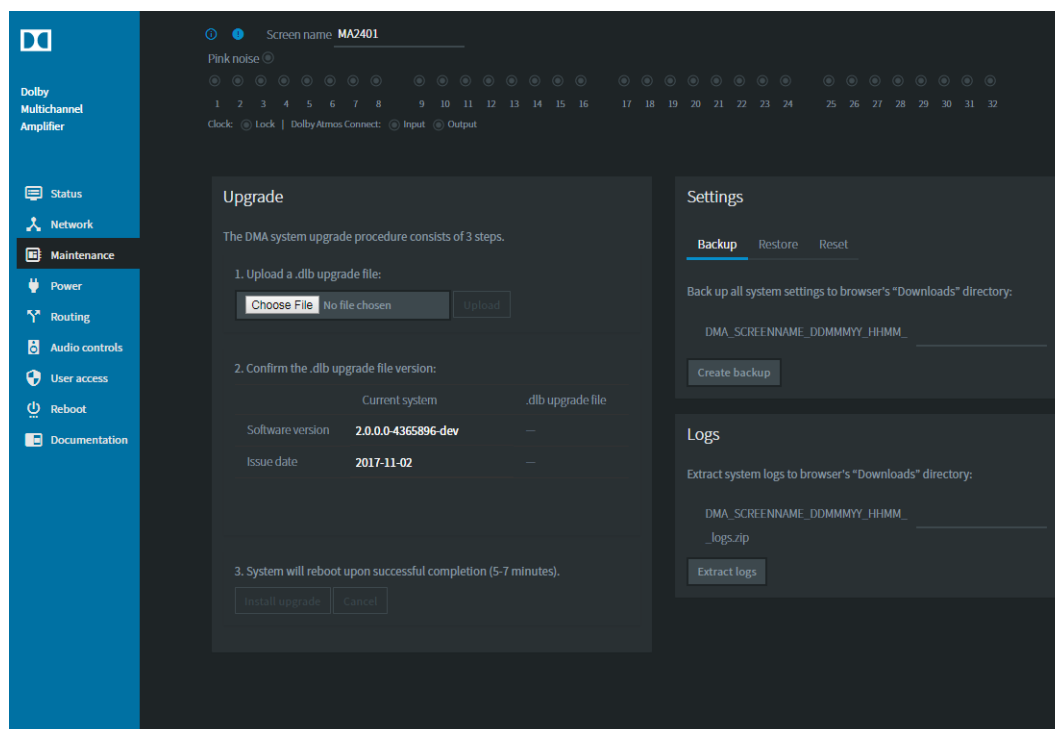

**Figure 3-7** Maintenance Screen

Following is a description of all the maintenance tasks.

#### Upgrade

To upgrade your Dolby Multichannel Amplifier system software:

1. Obtain the .dlb upgrade file from Dolby Laboratories at <https://www.dolbycustomer.com>.
2. Copy the upgrade file to your local disk.
3. Click **Choose File** to browse to the upgrade file, and then click the **Upload** button.
4. Confirm the displayed upgrade file version, and then click the **Install Upgrade** button. If you need to cancel, click the **Cancel** button.

5. Enter your password at the prompt. (The default password is *password*.)

The system initiates the upgrade process, displays the progress, and reboots the Dolby Multichannel Amplifier when the upgrade is completed.

#### Settings

To back up your system settings:

1. Click the **Backup** button, and enter a name for your .dac restore file.
2. Click the **Create backup** button to save the .dac restore file in your browser downloads directory on your PC.

To restore your system settings:

1. Click the **Restore** button, then click **Choose File** to select a .dac restore file. You can select from four restore options: **All settings**, **Network tab settings only**, **AC Mains tab settings only**, and **Channel configuration tab settings only**.

If you need to cancel, click the **Cancel** button.

2. Click the **Upload and restore** button to run the restoration process.

To reset your system settings:

1. Click the **Reset** button.

You can reset your system to the factory defaults (except for network tab settings). If you need to cancel, click the **Cancel** button.

2. Click the second **Reset** button at the lower-left side of the settings pane to run the reset operation.

## Logs

To download system logs, enter a name for your logs .zip file, then click the **Extract logs** button to save a .zip file containing your logs in your browser downloads directory on your PC.

## Alternative Maintenance Procedures

A dedicated Dolby Multichannel Amplifier maintenance application, separate from the web client user interface, is provided for cases where there may be system issues. In such a case, you can use a USB drive to upgrade the system, back up and restore settings, and extract logs.



---

**Note:** If you are using a cable to connect a USB drive, be sure to use a shielded USB cable.

---

## Alternative USB Upgrade Procedure

To perform this operation:

1. Obtain the .dlb upgrade file from Dolby Laboratories at <https://www.dolbycustomer.com>, and copy it to the root (top) level of a USB drive. Supported file systems are vFAT, FAT32, FAT16, and NTFS.

We recommend that your USB drive does not include any other files or folders.

2. Insert the USB drive into the Dolby Multichannel Amplifier USB port, and then reboot the unit by clicking **Reboot** in the navigation bar.

The system mounts the drive and checks for the presence of the upgrade .dlb file. If a .dlb file is present, the system compares the version number of the file to the currently installed version. If the currently installed version is older, the system starts the upgrade. After the upgrade is complete, the system automatically reboots.

If you insert a USB drive after the boot process begins, no upgrade is performed. The USB-based upgrade is performed only when the drive is inserted prior to booting up.

If the upgrade fails, the system performs the backup/restore/logs extract process, as described in the next section, and then unmounts the drive.

### Alternative USB Backup, Restore, and Extract Logs Procedure

When you insert a USB drive that does not contain an upgrade file, you can perform the following tasks:

- Download a backup of the system settings to a `dma_backup.dac` file on the USB drive.
- Extract a copy of the system logs to the USB drive.
- Restore system settings to factory defaults if you save a text file with the name `dma_restore_defaults`, remove the `.txt` extension, and include the file on the USB drive.
- Restore system settings from a `dma_backup.dac` file if you change the name of that file to `dma_restore.dac` and include it on the USB drive.

To perform the above tasks, insert a USB drive into the Dolby Multichannel Amplifier USB port. The system mounts the drive and automatically performs the following operations:

- Backs up the current settings on the USB drive. The settings file is named `dma_backup<N>.dac`, where N is a sequence number. The sequence number is determined as the system scans the drive to detect any previously created backup files. If none are found, the system creates `dma_backup0.dac`. If previous backups are found, the system uses the next number in the sequence.
- Extracts logs to a `.zip` file using the same sequence scheme as for backing up settings: `dma_logs0.zip`, `dma_logs1.zip`, and so on.
- Checks the USB drive for a file named `dma_restore_defaults`. If the system finds this file, the system settings are restored to the factory defaults.
- If no `dma_restore_defaults` text file was found, the system checks the USB drive for a `dma_restore.dac` file. If such a file is found, the system restores your backup settings from the `.dac` file.

After the system restores any settings, the main Dolby Multichannel Amplifier application rereads the settings and applies them. In addition, the system saves a `.dma_restore_complete.dac` file on the USB drive to confirm the restoration, and deletes the other restore files from the USB drive to avoid repeating the restore operation.



**Note:** The USB port LED on the Dolby Multichannel Amplifier flashes during USB access. Do not remove the USB drive while the LED is flashing.

---

At the end of this procedure, the system unmounts the USB drive.

### 3.2.4 Power

To configure the power parameters, click **Power** in the navigation bar. In this screen, you can set the circuit breaker parameters for your load center, enable/disable bridging for the desired channel pairs, set the unit to resume after a power interruption, and configure channels. After entering your settings, click **Apply** (or **Cancel** to undo).

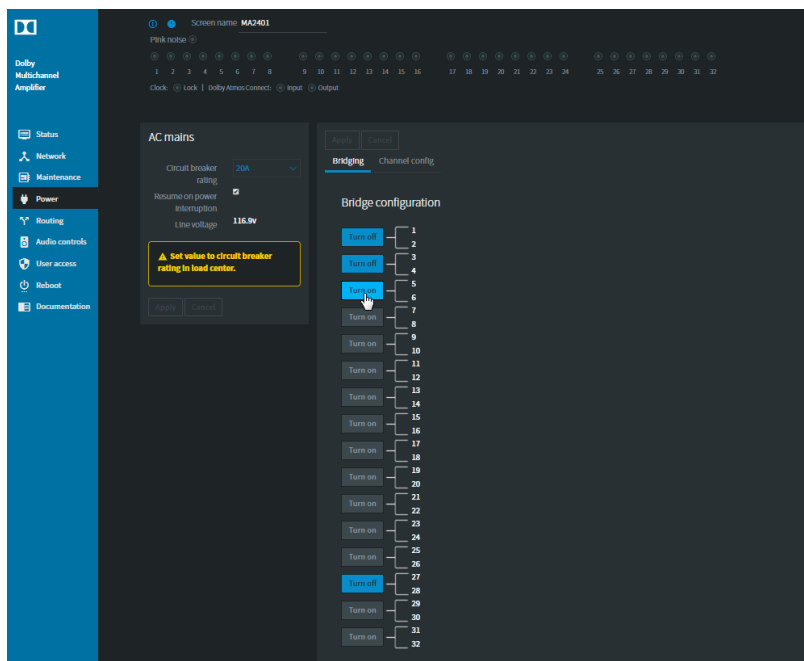

Figure 3-8 Power Screen Bridge Configuration

#### Bridging

This option allows you to configure bridging for Dolby Multichannel Amplifier outputs by hovering the mouse over the **Turn on** button next to a channel pair. The corresponding button will then illuminate in blue. You click on this button to turn on bridging and the button changes to **Turn off**, in which case, you click on it to turn bridging off.



**Note:** You must configure any bridged channels before setting up your [Routing](#) assignments.



**Note:** For DMA24300 and DMA32300 systems with version 1.0.xx software, bridging channels results in a loss of the even numbered output for use on other speakers. For example, when you bridge channels 1 and 2, you cannot use channel 2. Upgrading to version 2.x.x software or higher provides improved routing options that allow you to use the even numbered channels.

#### Resume On Power Interruption

When you check this option, the system enables the Dolby Multichannel Amplifier to automatically turn itself on if the AC mains input power is interrupted. Once the AC mains input is reapplied, the unit automatically turns on and there is no need to press the front-panel power button.

### Channel Config

This option enables you to view the channel configuration and activate or deactivate load monitoring by toggling the **On/Off** button for the respective channels. The Dolby Multichannel Amplifier load monitoring feature enables the system to notify users of basic load fault conditions. These faults include opens and shorts across the speaker terminals. If the system detects an open or short, a notification appears on the **Status** screen. You can also adjust the **Impedance Threshold** for each channel. The impedance threshold defaults provide appropriate headroom for typical 2, 4, and 8 ohm speaker impedances.

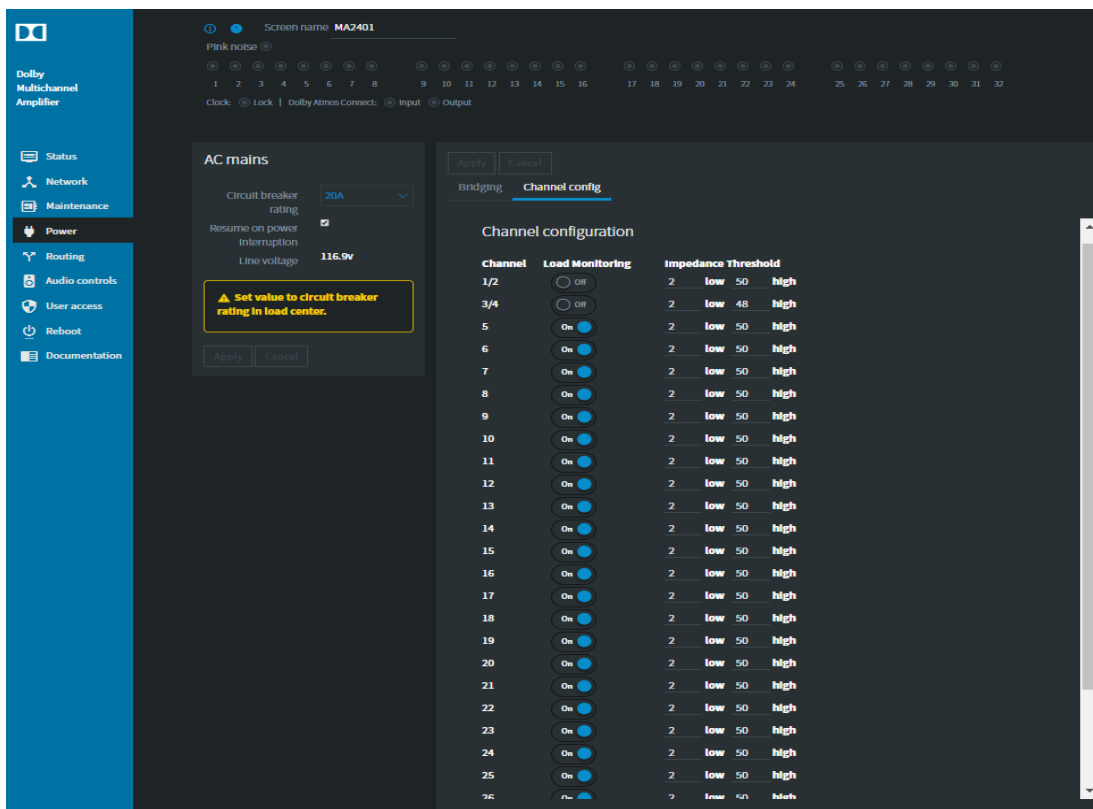
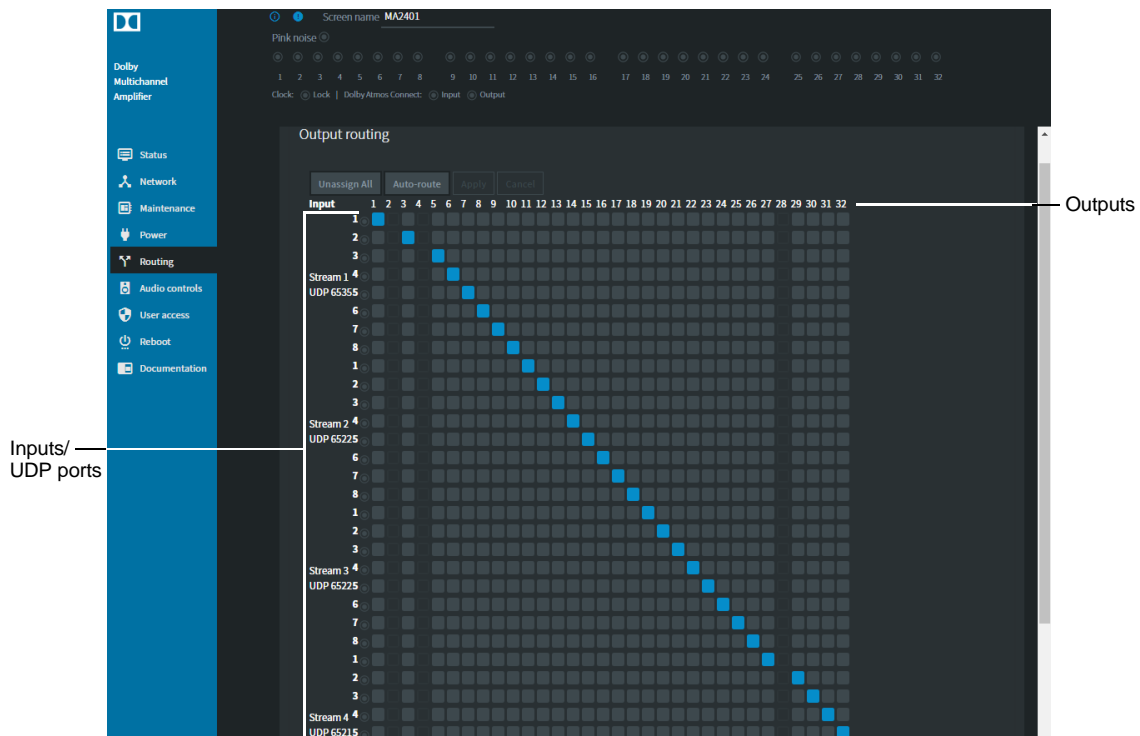

Figure 3-9 Power Screen Channel Configuration

After entering your settings in the power screen, click **Apply** (or **Cancel** to undo).

### 3.2.5 Routing

Version 2.x.x and later of the Dolby Multichannel Amplifier software provides easy routing of inputs to the connected speakers. To configure the routing parameters, click **Routing** in the navigation bar. The amplifier can receive up to five input streams of eight channels. Input streams and the respective UDP ports appear on the left side of the screen, and outputs are listed on top. The UDP ports correspond to the UDP settings in the **Network>Dolby Atmos Connect** screen. The number of outputs corresponds to the number of amplifier cards installed. The amplifier is shipped with no routing assignments, and no audio is transmitted until you configure routing.



**Figure 3-10** Output Routing Screen

To configure routing, click in an output box in the row next to the desired input stream; the box is then highlighted in blue to show the corresponding routing output. If you click again in a highlighted box, that assignment is removed. You can assign individual inputs to one or more outputs. However, you cannot assign multiple inputs to an output.



**Note:** To configure bridged channels, you must select **Power** in the navigation bar and set up bridging before configuring your routing assignments.

Bridged channels are represented as one output but input channels are not skipped in the automatic routing map. You can route an input to the first channel of a bridged pair, but cannot route an input to the second channel of a bridged pair. In the previous figure, channels 1 and 2, channels 3 and 4, and channels 27 and 28 are bridged.

If you click the **Auto-route** button, the system looks for every available input channel, and assigns consecutive outputs to consecutive inputs (input 1 to output 1, input 2 to output 2, and so on). If you click **Unassign all**, the system removes the routing assignments.

Click **Apply** to save your routing assignments or **Cancel** to discard your changes.

### 3.2.6 Audio Controls

To control audio, click **Audio controls** in the navigation bar. In this screen, you can output pink noise, set global audio delay, and configure channel gain.

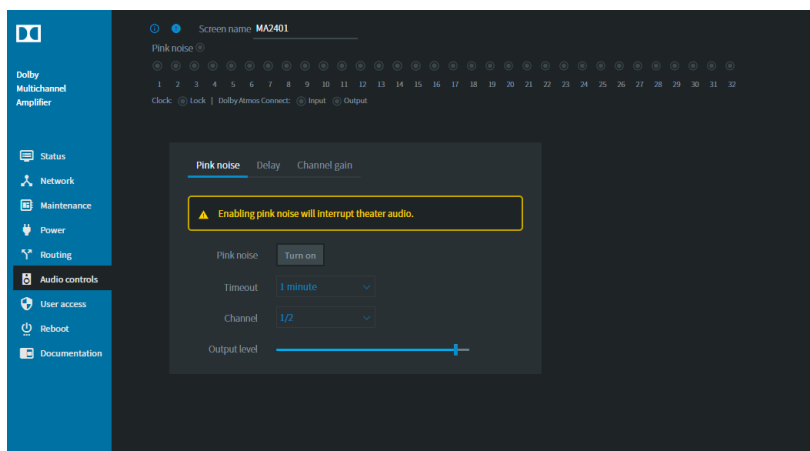

Figure 3-11 Audio Controls Screen

#### Pink Noise

The Dolby Multichannel Amplifier can output pink noise to an auditorium, which enables you to verify speaker connections and basic operations without a playback device. To turn on pink noise, click the **Pink Noise** tab, then select the desired channel and pink noise time-out interval, and use the slider to adjust the pink noise output level. Then click the **Turn on** button to generate pink noise. The pink noise indicator at the top of the screen illuminates in green for the specified interval.



**Note:** The Dolby Multichannel Amplifier pink noise stimulus is broadband pink noise, and you should use care to ensure that the Dolby Multichannel Amplifier output level does not cause overexcursion to the attached loudspeakers.

To disable pink noise, click the red **Turn off now** button at the top of the screen or the red **Turn off** button. When set to 0 dB, the Dolby Multichannel Amplifier outputs broadband pink noise with a typical RMS output voltage of approximately 2.5 Vrms.

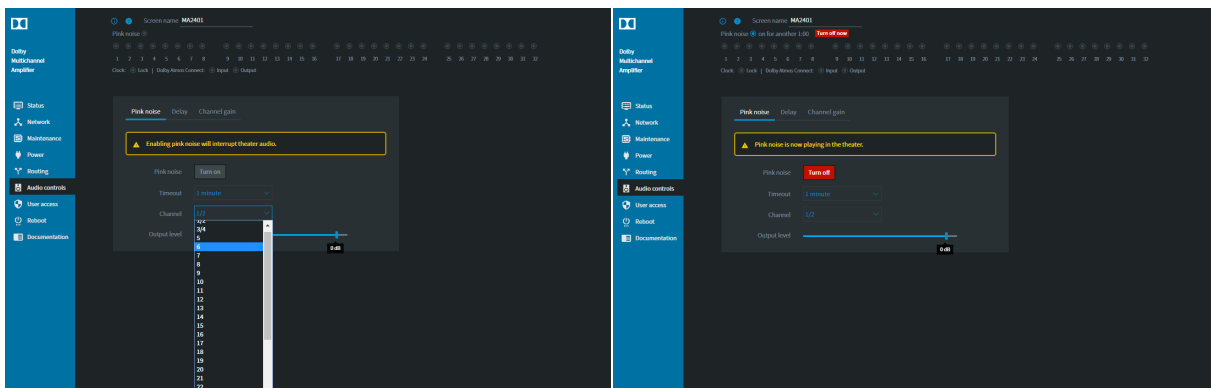

Figure 3-12 Turn On Pink Noise

### 3.2.7 Delay

When necessary, you can use the global audio delay parameter to synchronize audio. For example, multiple Dolby Multichannel Amplifiers and DAC3202s that are interconnected must be synchronized due to latency that requires compensation. However, if you are connecting these units through a switch, there is no latency, and you do not need to adjust this delay setting.

To adjust audio delay, click the **Delay** button and use the slider to specify the global audio delay for up to 336 samples (seven milliseconds), then click **Apply**.

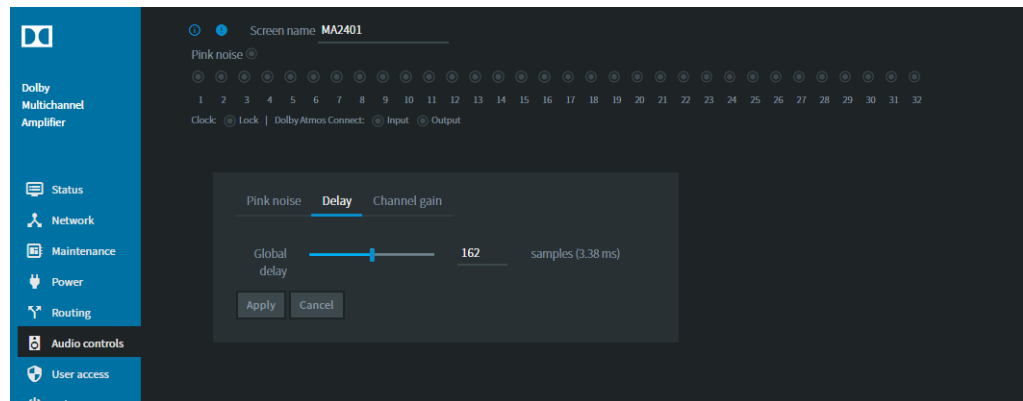

Figure 3-13 Adjust Audio Delay

### Channel Gain

You can use the channel gain parameter to adjust the output gain in 0.1 increments for specific output channels. Click the **Channel gain** button, select a channel from the **Channel** drop-down menu, use the **Output gain** slider to specify the desired gain within the range of +10 to -100 dB, and click **Apply**. The default gain value is 0 dB for current units. Units upgraded from earlier software versions display a default gain value of 10.88 dB.

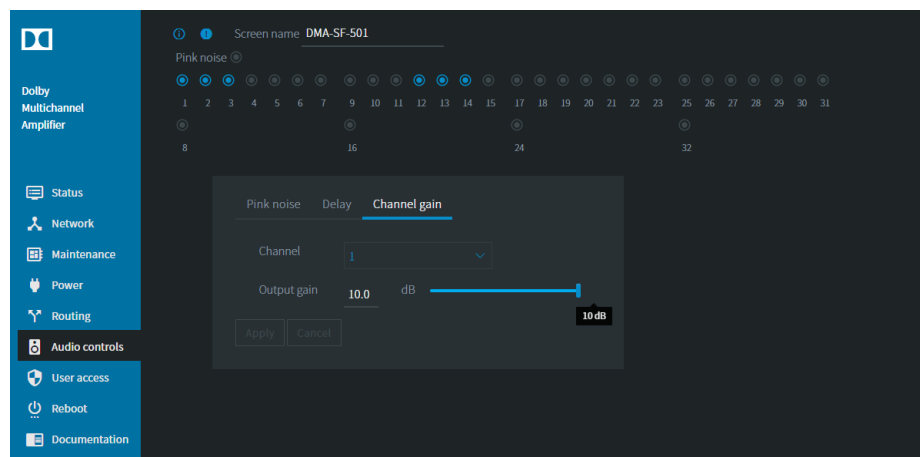

Figure 3-14 Adjust Channel Gain

### 3.2.8 User Access

To configure user access, click **User Access** in the navigation bar to display the password control screen. To change the password, enter the new password in the corresponding field, enter it again in the **Confirm password** field, and then click **Change password**.

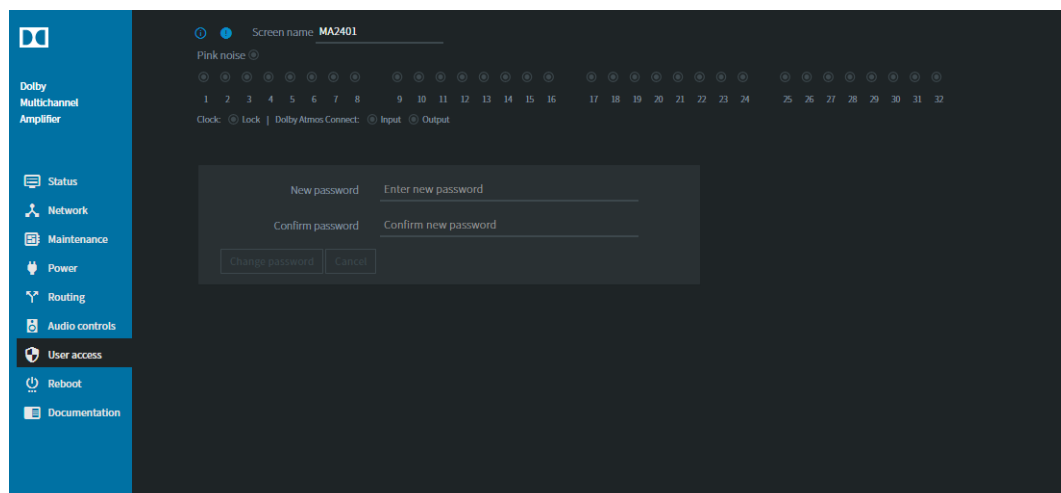

Figure 3-15 User Access Screen

### 3.2.9 Reboot

To reboot the Dolby Multichannel Amplifier, click **Reboot** in the navigation bar, enter your password at the prompt (or to cancel, click the **Cancel** button) and then click the **Reboot** button.

### 3.2.10 Documentation

To access Dolby Multichannel Amplifier user documentation, click **Documentation** in the navigation bar.

# Specifications

## A.1 AC Line Current Draw and Thermal Dissipation Specifications

The Dolby Multichannel Amplifier currently ships in three configurations: 16-channel version (DMA16301 with CAT1433 high-powered amplifier cards), and 24-channel (DMA24300) and 32-channel (DMA32300) versions with CAT1422 lower-powered amplifier cards.

DMA16301			120 VAC			208 VAC			230 VAC		
Output Level	Load	Output Configuration	Line Current (A, rms)	Dissipated Power (Watts, rms)	BTU/ Hour	Line Current (A, rms)	Dissipated Power (Watts, rms)	BTU/ Hour	Line Current (A, rms)	Dissipated Power (Watts, rms)	BTU/ Hour
Idle	-	-	1.86	214	730	1.4	205	699	1.3	199	679
1/8 power pink noise	2Ω	Normal	16.2	674	2,300	9.4	659	2249	8.4	638	2,177
	4Ω	Normal	16.0	639	2,180	9.2	606	2068	7.9	550	1,877
	4Ω	Bridged	17.0	858	2,928	9.3	754	2,573	8.3	725	2,474
	8Ω	Normal	8.6	404	1379	4.9	385	1314	4.4	359	1225
	8Ω	Bridged	14.9	639	2,180	8.6	591	2017	7.6	565	1928
1/4 power pink noise	2Ω	Normal	See Note 5			17.9	1,169	3,989	16.3	1192	4067
	4Ω	Normal				16.7	889	3,033	14.8	845	2,883
	4Ω	Bridged				17.2	1,191	4,064	15.6	1,213	4,139
	8Ω	Normal	14.7	506	1727	8.3	461	1,573	7.5	448	1529
	8Ω	Bridged	See Note 5			15.9	929	3,170	14.2	888	3,030

### Notes:

1. Pink noise stimulus with 12 dB crest factor, band-limited 20 Hz to 20 kHz.
2. Data based on all driven channels.
3. Fractional output levels are based upon rated channel power for the given load impedance. (For example, for a 1/8 power 8 ohm normal configuration, the net output power is 300 W/8 x 32 channels = 1200 W. )
4. Specifications for the DMA16301 are based on laboratory measurements and should be considered typical values, as they do not constitute absolute limits.
5. 120 VAC 1/4th power pink noise tests for this loading configuration are limited by duration due to AC mains breaker rating. Amplifier output limiting occurs to reduce current draw.

<b>DMA32300</b>			<b>120 VAC</b>			<b>208 VAC</b>			<b>230 VAC</b>		
<b>Output Level</b>	<b>Load</b>	<b>Output Configuration</b>	<b>Line Current (A, rms)</b>	<b>Dissipated Power (Watts, rms)</b>	<b>BTU/ Hour</b>	<b>Line Current (A, rms)</b>	<b>Dissipated Power (Watts, rms)</b>	<b>BTU/ Hour</b>	<b>Line Current (A, rms)</b>	<b>Dissipated Power (Watts, rms)</b>	<b>BTU/ hour</b>
Idle	-	-	2.1	227	775	1.5	227	775	1.5	227	775
1/8 power pink noise	4Ω	Normal	15.2	576	1,965	8.8	548	1,870	7.8	540	1,843
	8Ω	Normal	15.1	567	1,935	8.6	525	1,791	7.7	518	1,767
	8Ω	Bridged	15.7	631	2,153	8.8	550	1,877	8.1	606	2,068
1/4 power pink noise	4Ω	Normal	See Note 5			15.9	859	2,931	14.5	816	2,784
	8Ω	Normal				15.1	701	2,392	13.8	646	2,204
	8Ω	Bridged				16.4	950	3,242	14.8	898	3,064

<b>DMA24300</b>			<b>120 VAC</b>			<b>208 VAC</b>			<b>230 VAC</b>		
<b>Output Level</b>	<b>Load</b>	<b>Output Configuration</b>	<b>Line Current (A, rms)</b>	<b>Dissipated Power (Watts, rms)</b>	<b>BTU/ Hour</b>	<b>Line Current (A, rms)</b>	<b>Dissipated Power (Watts, rms)</b>	<b>BTU/ Hour</b>	<b>Line Current (A,rms)</b>	<b>Dissipated Power (Watts,rms)</b>	<b>BTU/ Hour</b>
Idle	-	-	1.8	196	689	1.5	196	669	1.4	196	669
1/8 power pink noise	4Ω	Normal	11.4	432	1,474	6.6	411	1,402	5.9	405	1,382
	8Ω	Normal	11.3	425	1,451	6.5	394	1,344	5.8	389	1,326
	8Ω	Bridged	11.8	473	1,615	6.6	413	1,408	6.1	455	1,551
1/4 power pink noise	4Ω	Normal	See Note 5			11.9	644	2,198	10.9	612	2,088
	8Ω	Normal				11.3	526	1,794	10.3	485	1,653
	8Ω	Bridged				12.3	713	2,431	11.1	674	2,298

<b>DMA16300 (No longer available)</b>			<b>120 VAC</b>			<b>208 VAC</b>			<b>230 VAC</b>		
<b>Output Level</b>	<b>Load</b>	<b>Output Configuration</b>	<b>Line Current (A, rms)</b>	<b>Dissipated Power (Watts, rms)</b>	<b>BTU/ Hour</b>	<b>Line Current (A, rms)</b>	<b>Dissipated Power (Watts, rms)</b>	<b>BTU/ Hour</b>	<b>Line Current (A,rms)</b>	<b>Dissipated Power (Watts, rms)</b>	<b>BTU/ Hour</b>
Idle	-	-	1.5	152	519	1.3	152	519	1.3	152	519
1/8 power pink noise	4Ω	Normal	7.7	291	993	4.4	277	944	4.0	273	930
	8Ω	Normal	7.6	286	977	4.4	265	905	3.9	262	893
	8Ω	Bridged	7.9	319	1,087	4.4	278	948	4.1	306	1,044
1/4 power pink noise	4Ω	Normal	14.3	408	1,393	8.0	434	1,480	7.3	412	1,406
	8Ω	Normal	13.3	322	1,100	7.6	354	1,208	7.0	326	1,113
	8Ω	Bridged	14.3	408	1,393	8.3	480	1,637	7.5	453	1,547

**Notes:**

1. Pink noise stimulus with 12 dB crest factor, band-limited 20 Hz to 20 kHz.
2. Data based on all driven channels.
3. Full power = 32 channels at 300 Wrms per channel (same net power for bridged mode; 16 channels at 600 Wrms per channel).
4. Specifications are based on laboratory measurements and should be considered typical values, as they do not constitute absolute limits.
5. 120 VAC 1/4th power pink noise tests are limited by duration due to AC mains breaker rating. Amplifier output limiting occurs to reduce current draw.
6. Specifications for the DMA24300 and DMA16300 are mathematically derived from the laboratory measurements made on the DMA3200.

**A.2 DMA16301 Audio Specifications**

Parameter	Typical Performance Specification			Measurement Notes
	Unbridged	Bridged		
Power output rating	300 watts	1100 watts	8Ω	<b>Dolby power amplifier rating specifications:</b> 1. Burst: 1 kHz for 20 ms, 10 kHz for 10 ms, two channels driven 2. Short term: 20 Hz, 1 kHz, and 20 kHz at -1 dB for five seconds, two channels driven 3. Long term: 1/8th power pink noise for one hour, two channels driven
	600 watts	1100 watts	4Ω	
	600 watts	NA	2Ω	
Power budget rating (total audio power available)	<b>120 VAC</b>	<b>208 VAC</b>	<b>230 VAC</b>	<b>For full-range specification:</b> 1. Burst 50Hz for 200msec, 1 kHz for 20 ms, 10 kHz for 10 ms 2. Short term 20 Hz, -1 dB for five seconds 3. Total power summed across all channels driven prior to any limiting
Full-range	1980 watts	3480 watts	3480 watts	
THD+N (1 kHz)	0.004%–0.009%		8Ω	1 dB below rated power, AES-17 20 kHz LPF, two adjacent channels driven in normal mode
	0.009%–0.02%		4Ω	
THD+N (20 Hz - 20 kHz)	0.05%		8Ω	
	0.10%		4Ω	
Frequency response	20 Hz-20 kHz, +0.4 dB/-0.2 dB		8Ω	
Intermodulation distortion ratio (SMPTE 4:1)	0.05%			1dB below rated power, SMPTE 4:1 60 Hz and 7 kHz, AES17 20 kHz lowpass filter
Signal-to-noise ratio	109 dB			A-weighted, AES17 20 kHz lowpass filter
Channel separation crosstalk	70 - 90 dB		8Ω	Depending upon channel utilization, measured at 1 kHz
DC offset	< ±5 mV			
Output impedance	44 mΩ			
Damping factor	180		8Ω	Measured 20 Hz–1 kHz

### A.3 DMA32300, DMA24300, and DMA16300 Audio Specifications

Parameter	Typical Performance Specification			Measurement Notes
	Unbridged	Bridged		
Power output rating	300 watts	600 watts	8Ω	<b>Dolby power amplifier rating specifications:</b> 1. Burst: 1 kHz for 20 ms, 10 kHz for 10 ms, half channels driven 2. Short term: 20 Hz, 1 kHz, and 20 kHz at -1 dB for five seconds, quarter channels driven 3. Long term: 1/8th power pink noise for one hour, all channels driven
	300 watts	NA	4Ω	
THD+N (1 kHz)	0.004%–0.009%		8Ω	1 dB below rated power, AES-17 20 kHz LPF, two adjacent channels driven
	0.009%–0.02%		4Ω	
THD+N (20 Hz - 20 kHz)	0.05%		8Ω	
	0.20%		4Ω	
Frequency response	20 Hz-20 kHz, +0.4 dB/-0.2 dB		8Ω	
Intermodulation distortion ratio (SMPTE 4:1)	0.05%			1dB below rated power, SMPTE 4:1 60 Hz and 7 kHz, AES17 20 kHz LPF
Signal-to-noise ratio	109 dB			A-weighted, AES17 20 kHz LPF
Channel separation crosstalk	70 - 90 dB		8Ω	Depending upon channel utilization, measured at 1 kHz
DC offset	< ±5 mV			
Output impedance	44 mΩ			
Damping factor	180		8Ω	Measured 20 Hz–1 kHz



**Note:** These specifications provide typical values and do not represent absolute limits.

### A.4 Physical Specifications

Dimensions (product): 48.3 cm (19 inches) × 17.7 cm (7 inches) × 56.3 cm (22 inches)

Dimensions (shipping): 61.0 cm (24 inches) × 30.5 cm (12 inches) × 72.4 cm (28.5 inches)

Weight DMA16301 product: 60 pounds, shipping: 71 pounds

Weight DMA16300 product: 54 pounds, shipping: 65 pounds

Weight DMA24300 product: 58 pounds, shipping: 69 pounds

Weight DMA32300 product: 62 pounds, shipping: 73 pounds

Operating temperature range: 0–40°C

## Fuse Information

### B.1 Fuses

Several of the cards in the Dolby® Multichannel Amplifier contain fuses. Only Dolby authorized service technicians should test and replace these fuses after the unit has been unplugged from its power source for at least one full minute. We recommend that you keep these fuses on hand so they are available for the authorized technician when needed. You can purchase replacement fuses from local suppliers (but not from Dolby Laboratories). The following table lists the Dolby Multichannel Amplifier fuses:

**Table B-1** Dolby Multichannel Amplifier Fuses

Dolby Multichannel Amplifier Board	Quantity	Maximum Amps	Voltage	Blow Type	Manufacturer Part Number
CAT1422 and CAT1433	2	20 A	500VDC	Fast Blow	Littelfuse 0505020.MXP
CAT1423	3	10 A	500VDC	Slow Blow	Littelfuse 0477010.MXP
CAT1426	2	16 A	500VDC	Slow Blow	Littelfuse 0477016.MXP
CAT1427	1	2 A	250VAC	Slow Blow	Bel Fuse Inc 5HT 2-R
CAT1428	1	30 A	500VDC	Fast Blow	Littelfuse 0505030.MXP
CAT1428	1	10 A	250VAC	Slow Blow	Schurter 0001.2514