

DP2K-12C/11CX

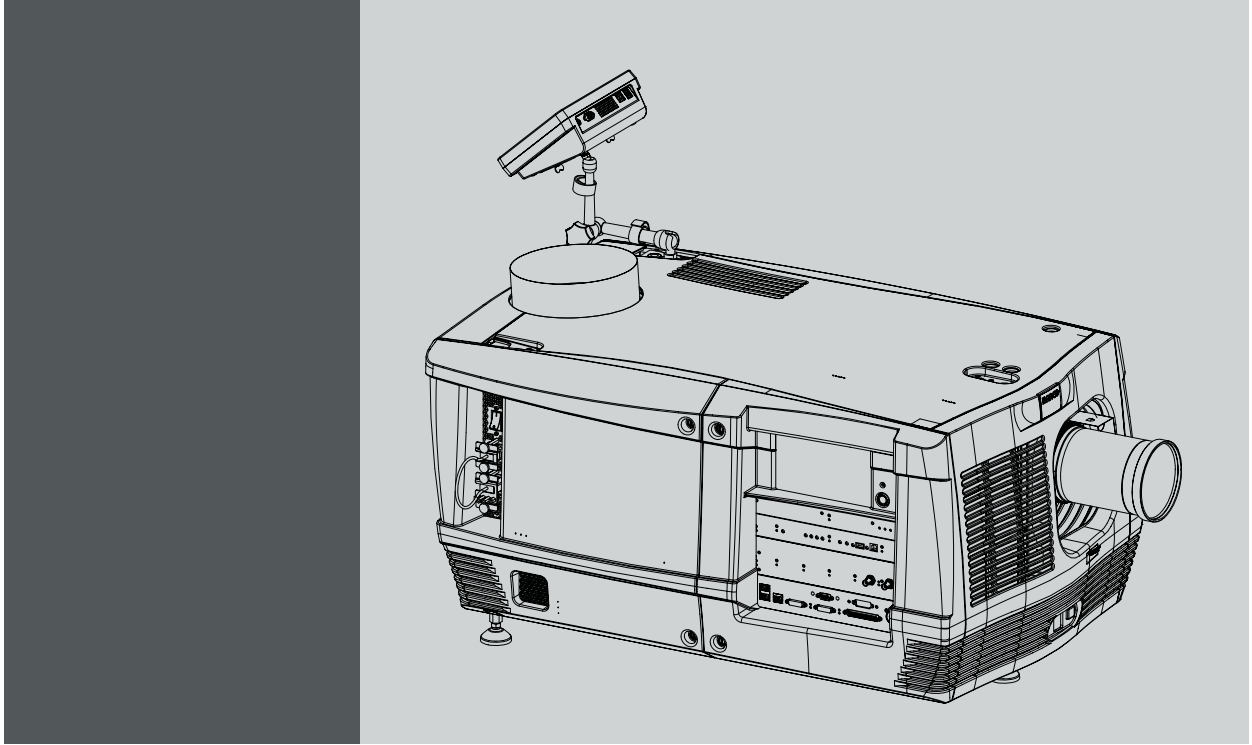

Service manual

Barco Inc. Media and Entertainment Division
11101 Trade Center Drive, Rancho Cordova, California 95670, USA
Phone: +1 916 859-2500
Fax: +1 916 859-2515
Support: www.barco.com/en/support
Visit us at the web: www.barco.com

Barco NV
President Kennedypark 35, 8500 Kortrijk, Belgium
Phone: +32 56.36.82.11
Fax: +32 56.36.883.86
Support: www.barco.com/en/support
Visit us at the web: www.barco.com

Copyright ©

All rights reserved. No part of this document may be copied, reproduced or translated. It shall not otherwise be recorded, transmitted or stored in a retrieval system without the prior written consent of Barco.

Trademarks

Brand and product names mentioned in this manual may be trademarks, registered trademarks or copyrights of their respective holders. All brand and product names mentioned in this manual serve as comments or examples and are not to be understood as advertising for the products or their manufacturers.

Changes

Barco provides this manual 'as is' without warranty of any kind, either expressed or implied, including but not limited to the implied warranties or merchantability and fitness for a particular purpose. Barco may make improvements and/or changes to the product(s) and/or the program(s) described in this publication at any time without notice.

This publication could contain technical inaccuracies or typographical errors. Changes are periodically made to the information in this publication; these changes are incorporated in new editions of this publication.

The latest edition of Barco manuals can be downloaded from the Barco web site www.barco.com or from the secured Barco web site <https://www.barco.com/en/signin>.

TABLE OF CONTENTS

| | |
|--|------------|
| 1. Safety | 5 |
| 1.1 Safety Instructions | 6 |
| 2. General | 9 |
| 2.1 Convention projector orientation | 10 |
| 2.2 Location of the main components of the projector | 11 |
| 2.3 About the Projector Status Light | 14 |
| 2.4 Projector block diagrams | 15 |
| 2.5 Spare parts for DP2K-12C/11CX | 17 |
| 3. Preventative maintenance actions | 19 |
| 3.1 Monthly maintenance actions | 20 |
| 3.2 Lamp change maintenance actions | 21 |
| 3.3 Three monthly maintenance actions | 22 |
| 3.4 Annually maintenance actions | 23 |
| 3.5 4 yearly maintenance actions | 26 |
| 4. Troubleshooting | 27 |
| 4.1 Troubleshooting checklist | 29 |
| 4.2 Log files | 74 |
| 5. Removal and installation of projector covers | 77 |
| 5.1 Removal of the lamp cover | 78 |
| 5.2 Removal of the input cover | 79 |
| 5.3 Removal of the front cover | 80 |
| 5.4 Removal of the side cover | 81 |
| 5.5 Removal of the rear cover | 82 |
| 5.6 Removal of the top cover | 83 |
| 5.7 Open the sealed compartment | 85 |
| 5.8 Close the sealed compartment | 86 |
| 5.9 Installation of the top cover | 87 |
| 5.10 Installation of the rear cover | 88 |
| 5.11 Installation of the side cover | 89 |
| 5.12 Installation of the front cover | 90 |
| 5.13 Installation of the input cover | 91 |
| 6. Lamps and lamp houses | 93 |
| 6.1 Introduction | 94 |
| 6.2 Removal of the lamp house | 96 |
| 6.3 Removal of the xenon lamp | 98 |
| 6.4 Installation of the Xenon lamp | 102 |
| 6.5 Installation of the lamp house | 108 |
| 6.6 Resetting the lamp parameters | 110 |
| 6.7 Realignment of the lamp in its reflector | 111 |
| 6.8 Replacement of the Lamp Info module | 113 |
| 6.9 Replacement of the UV blocker | 115 |
| 6.10 Replacement of the lamp reflector | 118 |
| 6.11 Cleaning the Reflector of the Lamp House | 121 |
| 6.12 Cleaning the UV blocker of the Lamp House | 122 |
| 7. Cold mirror assembly | 123 |
| 7.1 Introduction | 124 |
| 7.2 Removal of the cold mirror assembly | 125 |
| 7.3 Replace the Cold Mirror | 127 |
| 7.4 Installation of the cold mirror assembly | 129 |
| 7.5 Adjusting the cold mirror | 131 |
| 7.6 Cleaning the Cold Mirror | 133 |
| 8. Light processor assembly | 135 |
| 8.1 Introduction | 136 |
| 8.2 Light processor diagnostic | 138 |
| 8.3 Remove light processor top cover | 139 |
| 8.4 Electrical disconnection | 140 |
| 8.5 Light processor assembly removal | 141 |
| 8.6 Preparing the new light processor assembly | 142 |
| 8.7 Installation of the light processor assembly | 144 |
| 8.8 Electrical connections | 146 |
| 8.9 Mount light processor cover | 147 |
| 8.10 Mount light processor assembly into the flight case | 148 |
| 8.11 Finalize the installation of the light processor assembly | 150 |
| 8.12 Replacement of the Light Sensor Module | 151 |
| 8.13 Replacement of the dowser (shutter) | 152 |
| 8.14 Adjusting the notch filter | 154 |

| | | |
|------------|--|------------|
| 8.15 | Cleaning the Prism exit side | 156 |
| 9. | Spatial Color Calibration (LUT-SCC)..... | 157 |
| 9.1 | Introduction to SCC file..... | 158 |
| 9.2 | Obtain the Serial Number of the installed Light Processor..... | 159 |
| 9.3 | Download the LUT-SCC file from the Barco website..... | 160 |
| 9.4 | Upload Spatial Color Calibration file..... | 162 |
| 9.5 | Activate Spatial Color Calibration file..... | 163 |
| 10. | Convergence | 165 |
| 10.1 | Convergence controls | 166 |
| 10.2 | Preparing the convergence adjustment..... | 168 |
| 10.3 | Red on Blue convergence..... | 169 |
| 10.4 | Green on Blue convergence | 171 |
| 11. | Integrator rod | 173 |
| 11.1 | Introduction | 174 |
| 11.2 | Rod diagnostic..... | 175 |
| 11.3 | Removal of the integrator rod | 176 |
| 11.4 | Installation of a new integrator rod..... | 179 |
| 11.5 | Adjusting the integrator rod | 183 |
| 12. | Lenses and Lens holder | 185 |
| 12.1 | Available lenses | 186 |
| 12.2 | Lens selection | 188 |
| 12.3 | Lens removal | 189 |
| 12.4 | Lens installation | 190 |
| 12.5 | Cleaning the lens | 192 |
| 12.6 | Remove the lens holder..... | 193 |
| 12.7 | Install the lens holder..... | 196 |
| 12.8 | Scheimpflug adjustment..... | 199 |
| 12.9 | Replacement of the Vertical Shift stepper motor | 203 |
| 12.10 | Replacement of the Horizontal Shift stepper motor | 205 |
| 12.11 | First Placement of the Inner Dust Rubber | 207 |
| 12.12 | Replacement of the Inner Dust Rubber..... | 211 |
| 13. | Card Cage..... | 215 |
| 13.1 | Fan controller board | 216 |
| 13.2 | Integrated Cinema Processor (ICP) board | 217 |
| 13.3 | HD-SDI board + link decryptor | 218 |
| 13.4 | Cinema controller board..... | 219 |
| 13.5 | Removing a board in the card cage..... | 221 |
| 13.6 | Inserting a board in the card cage | 222 |
| 13.7 | Replacement of the RTC battery of the ICP board | 223 |
| 13.8 | Battery replacement on the Cinema Controller Board | 225 |
| 13.9 | Removing the button unit..... | 227 |
| 13.10 | Installation of the button unit | 230 |
| 13.11 | Replacement of the Button module (first generation Keypad) | 231 |
| 13.12 | Replacement of the Keypad (first generation Keypad)..... | 234 |
| 13.13 | Replacement of the Keypad assembly (second generation Keypad)..... | 238 |
| 13.14 | Replacement of the signal back plane..... | 239 |
| 13.15 | Replacement of the Link Decryptor | 251 |
| 13.16 | Authorization to clear security warning on the projector | 253 |
| 13.17 | Replacement of the Status Light..... | 254 |
| 14. | Software update via Communicator (DC update companion)..... | 255 |
| 14.1 | Software upgrade, launch DC update companion..... | 256 |
| 14.2 | Software upgrade, projector, ICMP or touch panel..... | 259 |
| 14.3 | ICP software upgrade | 263 |
| 14.4 | Link decryptor software update | 266 |
| 14.5 | Update logging..... | 268 |
| 15. | Communicator touch panel..... | 269 |
| 15.1 | Introduction | 270 |
| 15.2 | Installing the touch panel interface..... | 272 |
| 15.3 | Reposition the touch panel interface..... | 274 |
| 16. | Power input..... | 275 |
| 16.1 | Introduction | 276 |
| 16.2 | Getting access to the Mains Input components | 277 |
| 16.3 | Replacement of the mains ON/OFF switch | 279 |
| 16.4 | Replacement of the mains input filter | 281 |
| 16.5 | Closing the Mains Input compartment | 283 |
| 17. | Switched mode power supply..... | 287 |
| 17.1 | Diagnostic LEDs on the SMPS..... | 288 |
| 17.2 | Replacement of the Switched Mode Power Supply | 289 |

| | |
|--|------------|
| 18. Lamp power supply | 291 |
| 18.1 Introduction | 292 |
| 18.2 LPS diagnostic LED's | 293 |
| 18.3 Removal of the LPS module | 295 |
| 18.4 Installation of the LPS module | 297 |
| 19. Lamp power supply (single module) | 299 |
| 19.1 LPS module diagnostic LED's..... | 300 |
| 19.2 Removal of the LPS module | 302 |
| 19.3 Installation of the LPS module | 304 |
| 19.4 Replacing a large frame LPS with a single module LPS..... | 307 |
| 20. Start Pulse Generator | 311 |
| 20.1 Introduction | 312 |
| 20.2 Troubleshooting..... | 313 |
| 20.3 Removal of the Start Pulse Generator..... | 314 |
| 20.4 Installation of the Start Pulse Generator..... | 316 |
| 21. Fan replacement procedure | 319 |
| 21.1 Card cage fans | 320 |
| 21.2 SMPS compartment fans..... | 322 |
| 21.3 Light processor compartment fan | 324 |
| 21.4 Lamp cathode fan | 327 |
| 21.5 Lamp anode fan | 332 |
| 21.6 Cold mirror fan..... | 335 |
| 21.7 Lamp Info Module fan | 337 |
| 21.8 Integrated cinema processor fan..... | 338 |
| 22. Maintenance procedures | 339 |
| 22.1 Cleaning the exterior of the projector | 340 |
| 22.2 Removing the front dust filter..... | 341 |
| 22.3 Clean the dust filter on the top side..... | 343 |
| A. Pin configurations | 345 |
| A.1 About General Purpose Inputs & Outputs (GPIO)..... | 346 |
| A.2 Pin configurations of the communication ports | 348 |
| A.3 Pin configurations of the ICMP communication ports | 350 |
| A.4 Pin configurations of the inputs | 353 |
| B. Input formats | 355 |
| B.1 Input formats..... | 357 |
| Index | 359 |

1. SAFETY

About this chapter

Read this chapter attentively. It contains important information to prevent personal injury while servicing the DP2K-12C/11CX projector. Furthermore, it includes several cautions to prevent damage to the DP2K-12C/11CX projector. Ensure that you understand and follow all safety guidelines, safety instructions and warnings mentioned in this chapter before servicing the DP2K-12C/11CX projector. After this chapter, additional "warnings" and "cautions" are given depending on the service procedure. Read and follow these "warnings" and "cautions" as well.



WARNING: This manual is only intended for qualified service personnel.

Overview

- Safety Instructions

1.1 Safety Instructions



WARNING: Before removing/replacing any projector components, disconnect the power to the unit mains terminals and unplug the power cord at UPS INLET.

Safety Instructions

1. Before returning an instrument to the customer, always make a safety check of the entire instrument, including, but not limited to, the following items:
 - a) Be sure that no built-in protective devices are defective and/or have been defeated during servicing. (1) Protective shields are provided on this chassis to protect both the technician and the customer. Correctly replace all missing protective shields, including any removed for servicing convenience. (2) When reinstalling the chassis and/or other assembly in the cabinet, be sure to put back in place all protective devices, including, but not limited to, insulating materials, barriers, covers/shields, and isolation resistor/capacitor networks. Do not operate this instrument or permit it to be operated without all protective devices correctly installed and functioning. Service people who defeat safety features or fail to perform safety checks may be liable for any resulting damage.
 - b) Be sure that there are no cabinet openings through which an adult or child might be able to insert their fingers and contact a hazardous voltage. Such openings include, but are not limited to, (1) excessively wide cabinet ventilation slots, and (2) an improperly fitted and/or incorrectly secured cover panels.
 - c) Leakage Current Hot Check. With the instrument completely reassembled, plug the AC line cord directly into a 220 V AC outlet (Do not use an isolation transformer during this test). Use a leakage current tester or a metering system that is designed to comply with the new IEC, ANSI and UL standards. With the instrument AC switch first in the on position and then in the off position, measure from a known earth ground (metal waterpipe, conduit, etc.) to all exposed metal parts of the instrument (antennas, handle bracket, metal cabinet, screwheads, metallic overlays, control shafts, etc.) especially any exposed metal parts that offer an electrical return path to the chassis. Any current measured must not exceed 3,5 mA. Reverse the instrument power cord plug in the outlet and repeat test. ANY MEASUREMENTS NOT WITHIN THE LIMITS SPECIFIED HEREIN INDICATE A POTENTIAL SHOCK HAZARD THAT MUST BE ELIMINATED BEFORE RETURNING THE INSTRUMENT TO THE CUSTOMER OR BEFORE CONNECTING ACCESSORIES.

AC Leakage Test

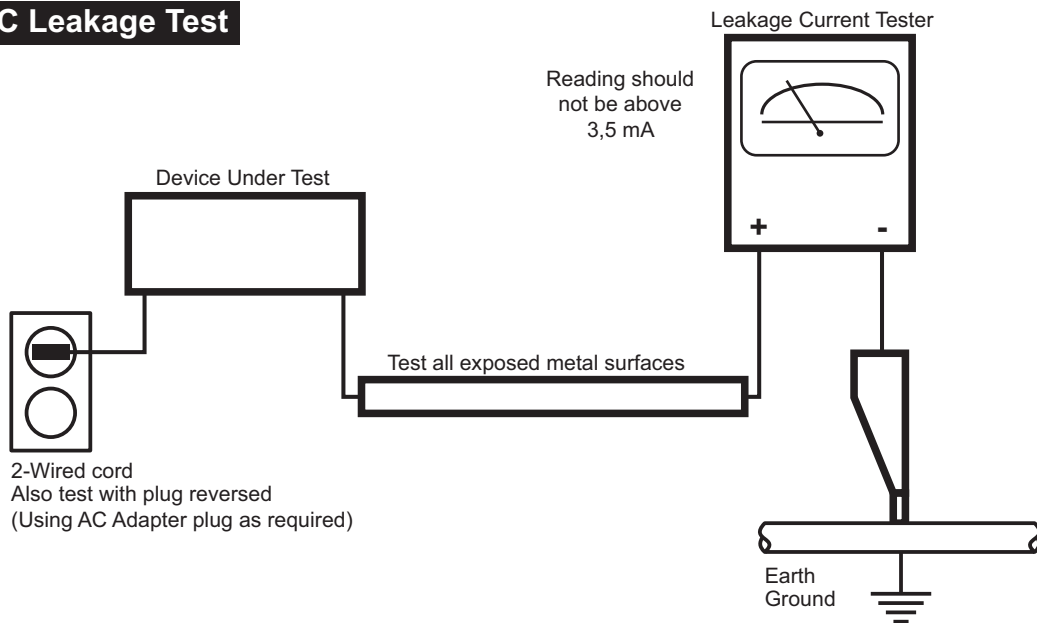

Image 1-1

- d) Ultraviolet Radiation exposure - Warning: This lamp can cause serious skin burn and eye inflammation from shortwave ultraviolet radiation if not operated in enclosed fixtures. DO NOT operate this lamp in a fixture with a missing or broken lens cover.
 - e) Ozone: Operating lamp generates ozone gas which is harmful to the respiratory system. Therefore the lamp should be operated in adequately ventilated equipment.
2. Read and comply with all caution and safety-related notes on or inside the projector cabinet or on the projector chassis, or on the picture tube.
 3. Design Alteration Warning - Do not alter or add to the mechanical or electrical design of this apparatus. Design alterations and additions, including, but not limited to, circuit modifications and the addition of items such as auxiliary audio and/or video output connections, might alter the safety characteristics of this apparatus and create a hazard to the user. Any design alterations or additions may void the manufacturer's warranty and may make you, the servicer responsible for personal injury or property damage resulting therefrom.

4. Lamp explosion Protection Warning – The lamp in this projector operates with a high internal pressure and there is a slight risk that the lamp may explode, particularly if it is used beyond its rated life. Do not remove, install, or otherwise handle the lamp in any manner without first putting on shatterproof goggles equipped with side shields. People not so equipped must be kept safely away while lamps are handled. Keep the lamp away from your body. For continued explosion protection, replace the lamp only with one of the same type number. Always replace the lamp before the rated life time.
5. Hot Chassis Warning - This projector chassis has two ground systems: the primary ground system is formed by the negative voltage of the rectified mains (power) and is only used as a reference in primary circuits; the secondary ground system is connected to earth ground via the earth conductor in the mains (power) lead. Separation between primary and secondary circuits is performed by the safety isolation transformers. Components bridging these transformers are also safety components and must never be defeated or altered. All user-accessible conductive parts must be connected to earth ground, or are kept at SELV (Safety Extra Low Voltage).
6. Observe original lead dress. Always inspect in all areas for pinched, out-of-face, or frayed wiring. Do not change spacing between components, and between components and the printed-circuit board. Check AC power cord for damage. Take extra care to assure correct lead dress in the following areas:
 - a) near sharp edges
 - b) near thermally hot parts - be sure that leads and components do not touch thermally hot parts
 - c) the AC supply
 - d) high voltage
7. Components, parts, and/or wiring that appear to have overheated or are otherwise damaged should be replaced with components, parts, or wiring that meet original specifications. Additionally, determine the cause of overheating and/or damage and, if necessary, take corrective action to remove any potential safety hazard.
8. PRODUCT SAFETY NOTICE - Many electrical and mechanical parts have special safety-related characteristics some of which are often not evident from visual inspection, nor can the protection they give necessarily be obtained by replacing them with components rated for higher voltage, wattage, etc. Use of a substitute replacement that does not have the same safety characteristics as the recommended replacement part in BARCO service data parts list might create shock, fire, and/or other hazards. Product Safety is under review continuously and new instructions are issued whenever appropriate. For the latest information, always consult the appropriate current BARCO service literature.
9. Do not spray chemical on or near this instrument or any of its assemblies.
10. Electrostatically Sensitive (ES) Devices Some semiconductor (solid state) devices can be damaged easily by static electricity. Such components commonly are called Electrostatically Sensitive (ES) Devices. Examples of typical ES devices are integrated circuits and some field-effect transistors and semiconductor "chip" components. The following techniques should be used to help reduce the incidence of component damage caused by static electricity:
 - a) Immediately before handling any semiconductor-equipped assembly, drain off any electrostatic charge on your body by touching a known earth ground. Wear a commercially available high impedance discharging wrist strap device.
 - b) After removing an electrical assembly equipped with ES devices, place the assembly on a static dissipative surface such as a 3M No 8210 table mat, to prevent electrostatic charge buildup or exposure of the assembly.
 - c) Do not use freon-propelled chemicals. These can generate electrical charges sufficient to damage ES devices.
 - d) Do not remove a replacement ES device from its protective package until immediately before you are ready to install it (Most replacement ES devices are packaged with leads electrically shorted together by conductive foam, aluminium foil or comparable conductive material).
 - e) Immediately before removing the protective material from the leads of a replacement ES device, touch the protective material to the chassis or circuit assembly into which the device will be installed. CAUTION: Be sure no power is applied to the chassis or circuit, and observe all other safety precautions.
 - f) Minimize bodily motions when handling unpacked replacement ES devices (Otherwise harmless motion such as the brushing together of your clothes fabric or the lifting of your foot from a carpeted floor can generate static electricity sufficient to damage an ES device).

2. GENERAL

About this chapter

This chapter contains some general information on projector level such as the location of the main components, internal wiring diagram, spare parts list, etc.

Overview

- Convention projector orientation
- Location of the main components of the projector
- About the Projector Status Light
- Projector block diagrams
- Spare parts for DP2K-12C/11CX

2.1 Convention projector orientation

Convention

This manual refer to the left side of the projector as the side at your left hand when standing behind the projector and looking at the projection screen in front of the projector.

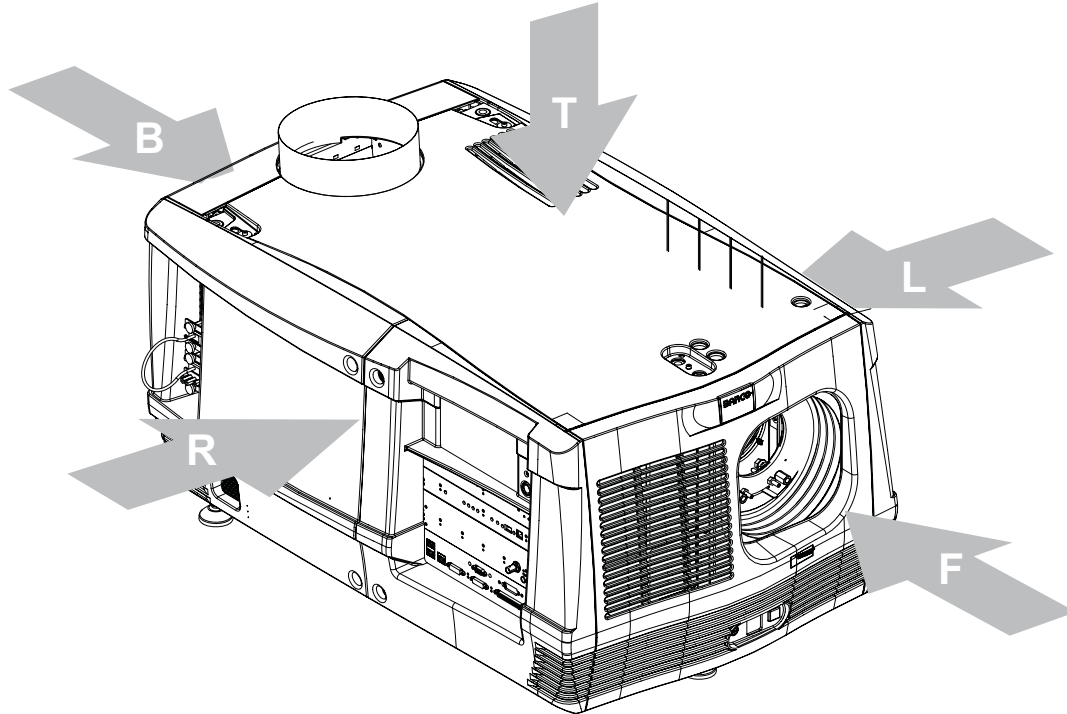

Image 2-1

- T Top of the projector.
- L Left side of the projector (Light Processor side).
- F Front of the projector.
- R Right side of the projector (Lamp side & Input side).
- B Back side of the projector.

2.2 Location of the main components of the projector

Housing and air inlet filters

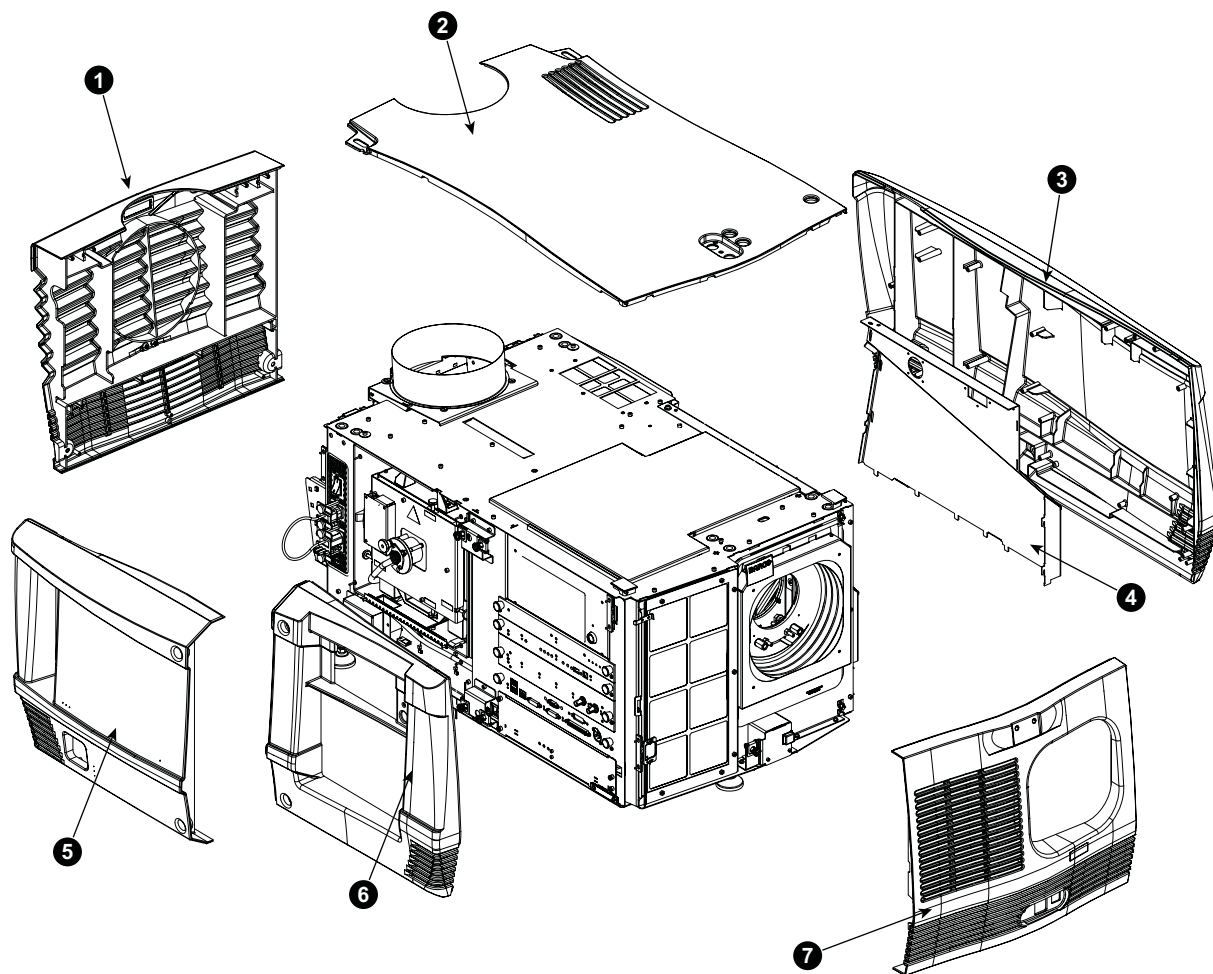
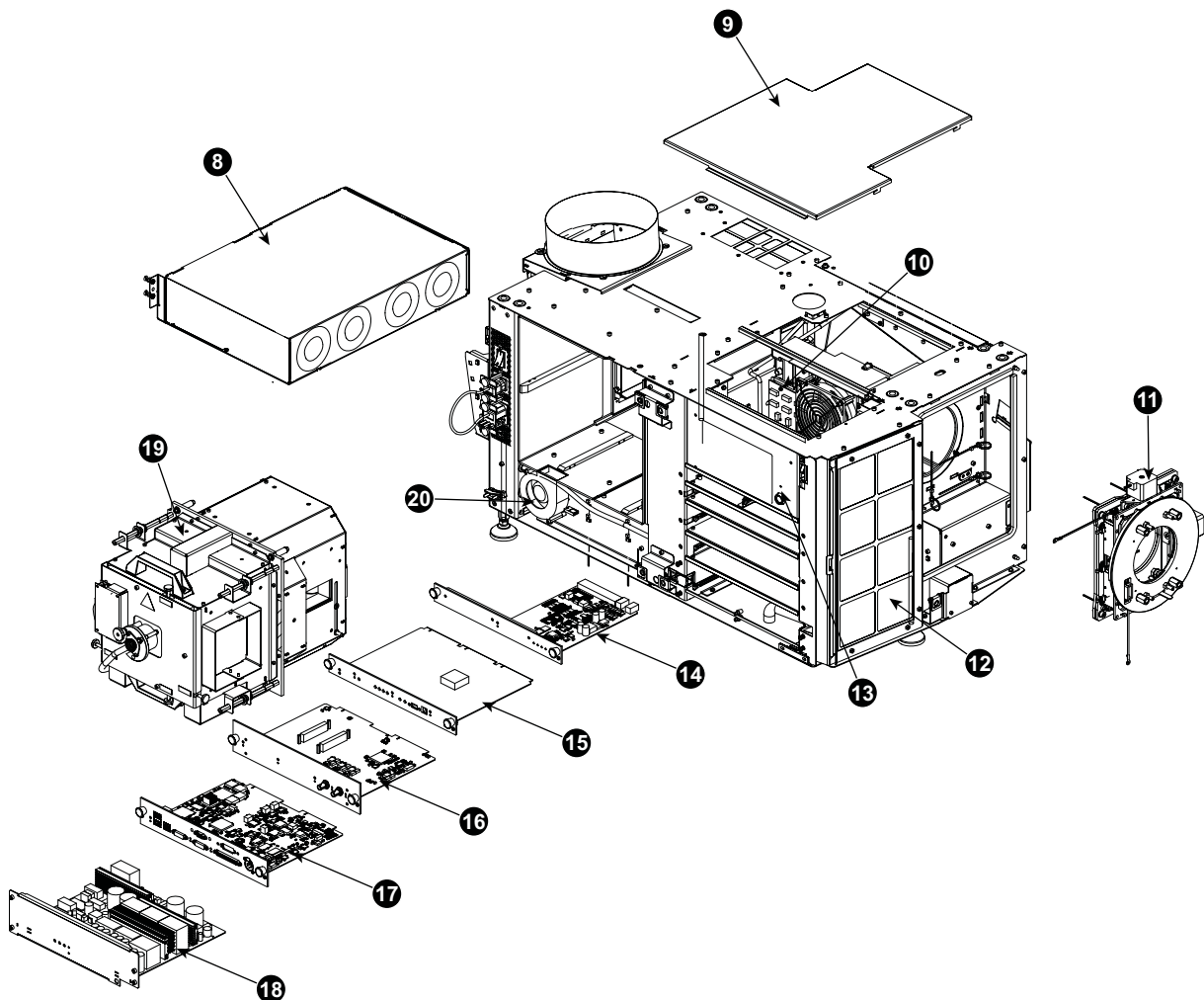

Image 2-2

- 1 Rear cover.
- 2 Top cover.
- 3 Left cover (Light Processor side).
- 4 Sealed compartment cover (Light processor side)
- 5 Lamp cover.
- 6 Input cover (Input & Communication unit).
- 7 Front cover.

Main internal components



- Image 2-3
- 8 Lamp Power Supply (LPS)
 - 9 Convergence cover plate
 - 10 Backplane + light processor compartment fan
 - 11 Lens holder assembly
 - 12 Front dust filter (cleanable)
 - 13 Button panel
 - 14 Fan controller board
 - 15 Integrated Cinema Processor board (ICP)
 - 16 HDS/SDI board or Mediablock
 - 17 Cinema controller board
 - 18 Switched mode power supply board
 - 19 Lamp house

20 Lamp info module fan

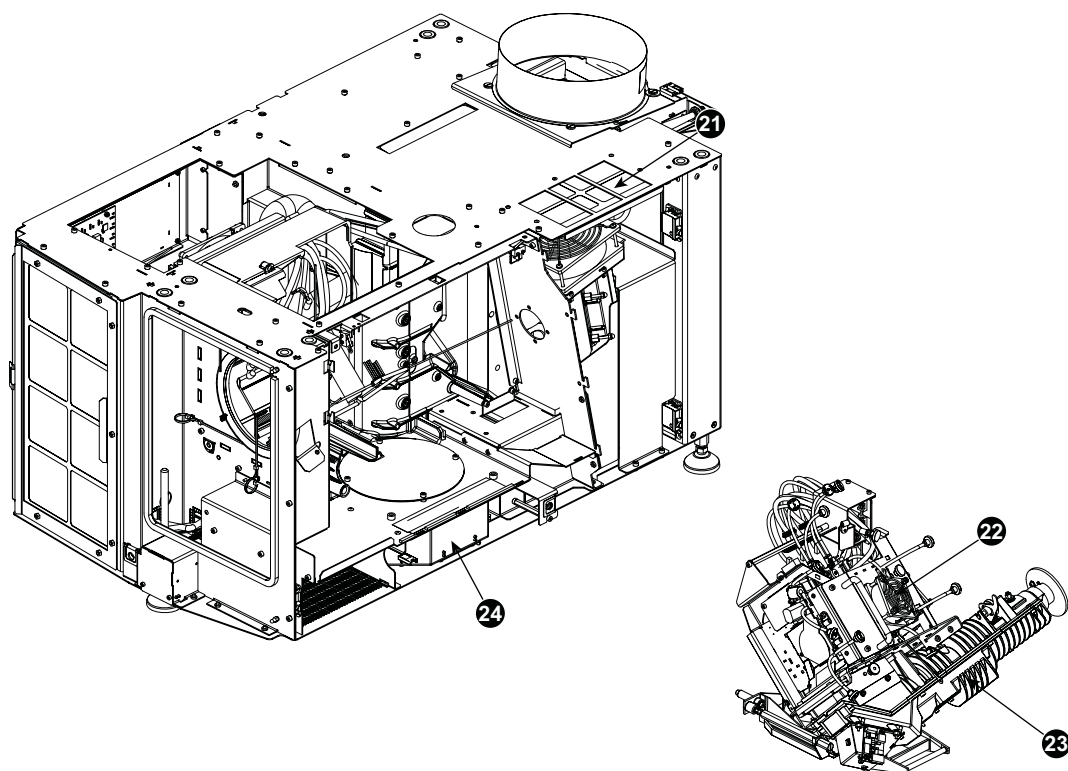

Image 2-4
 21 Dust filter cold mirror
 22 Light processor (assembly)
 23 Light pipe
 24 Anode fan assembly

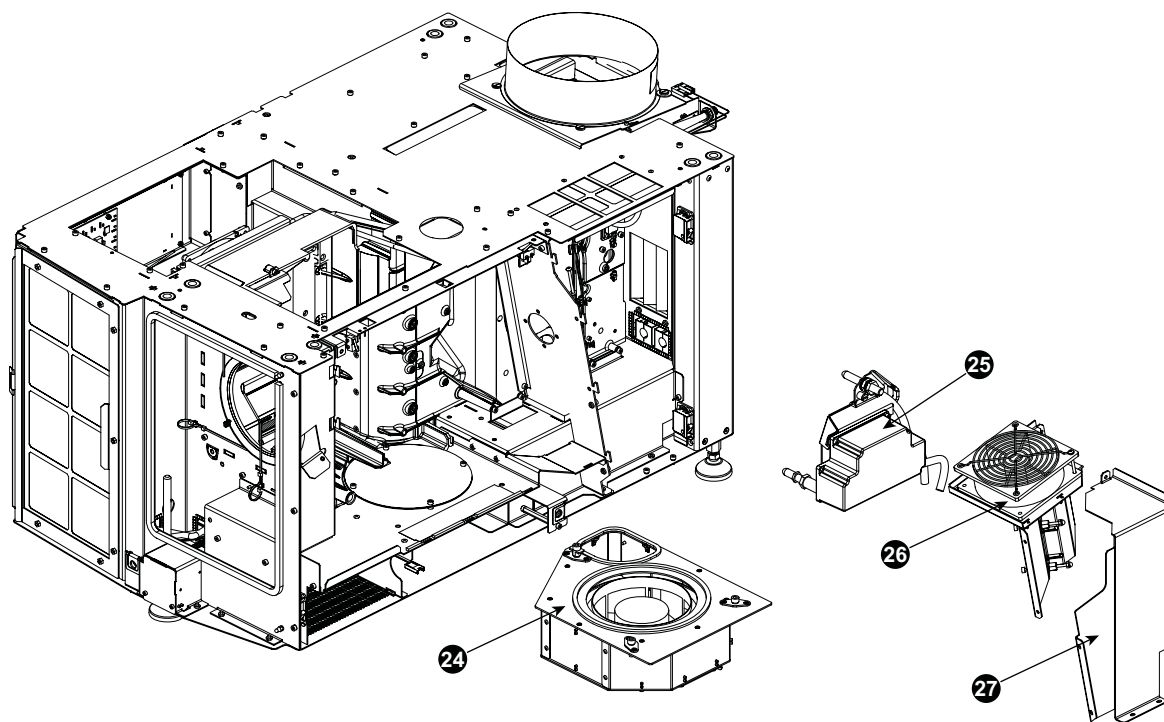

Image 2-5
 24 Anode fan assembly
 25 Start pulse generator (SPG)
 26 Cold mirror assembly
 27 SPG cover plate

2.3 About the Projector Status Light

Overview

The projector status light can have 4 colors:

| | |
|-----------------------|--|
| Flashing green | Projector is booting up. |
| Green | Projector is running normal. |
| Yellow | Projector is running with warnings. Event can go on but a technical intervention will be necessary in the near future to prevent a complete stop of the projector. |
| Red | Projector is in error state. Problem could prevent normal operation. Solve the problem before continuing with the projector. |
| Blue | Projector runs in notification state. Maintenance action required. Lamp run time is exceeded. New lamp must be installed. |

2.4 Projector block diagrams

General block diagram

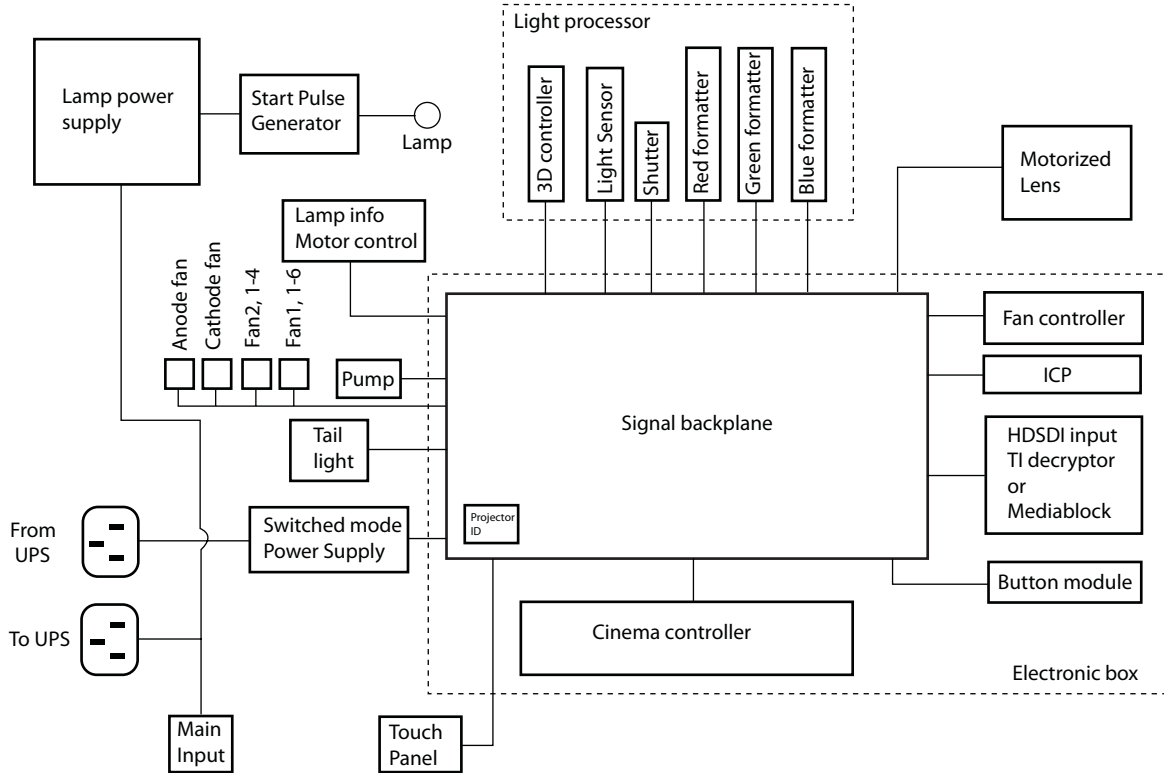

Image 2-6

Communication block diagram

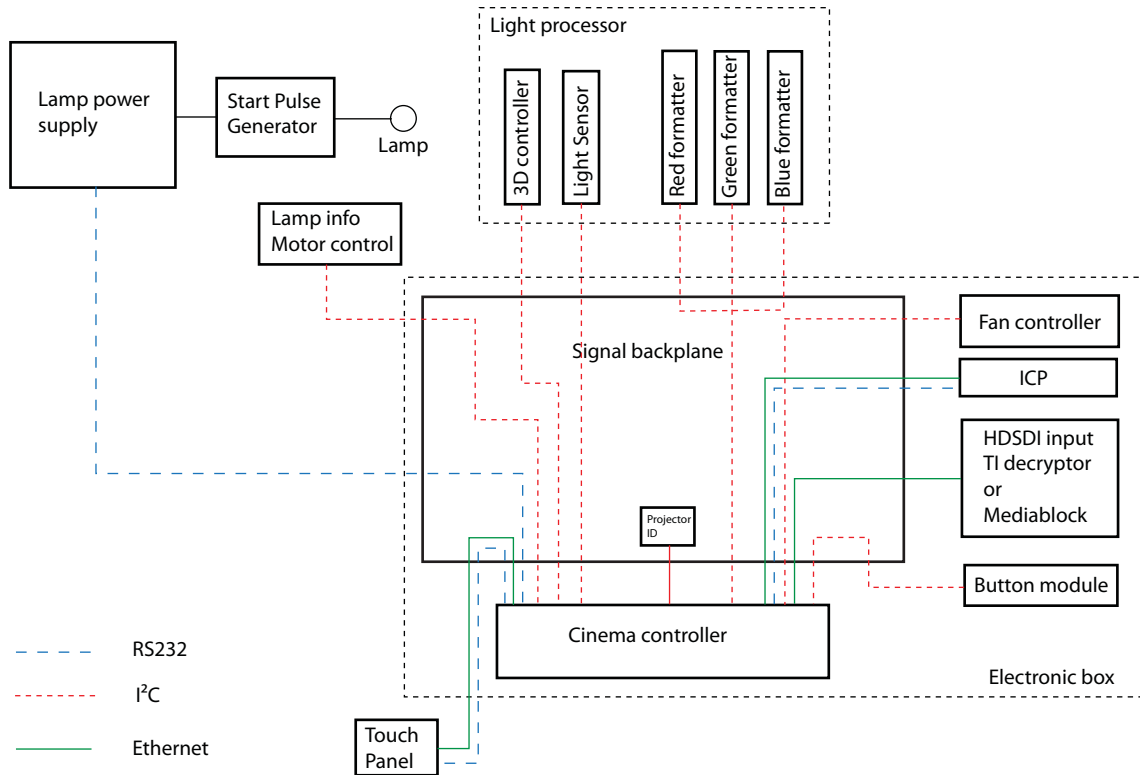

Image 2-7

2. General

- Any external command sent via Ethernet or serial will always be routed through the Cinema Controller to the Signal Backplane and then on to the end device
- Cinema Controller contains a multi port internal Ethernet router, connected to all internal Ethernet devices.
- Once the Cinema Controller receives the command, it will convert it into the necessary protocol to control the end device.
- TI controls its own devices with commands to perform functions coming from the Cinema controller or from cinema server/IMediablock.
- Decryption is handled by the Link decryptor or Mediablock.
- I²C communication between Fan Controller and Cinema Controller is used by the Fan Controller to send back error reporting to Cinema Controller
- Cinema Controller receives error reporting and sends it to the Communicator and the log files.

Video block diagram

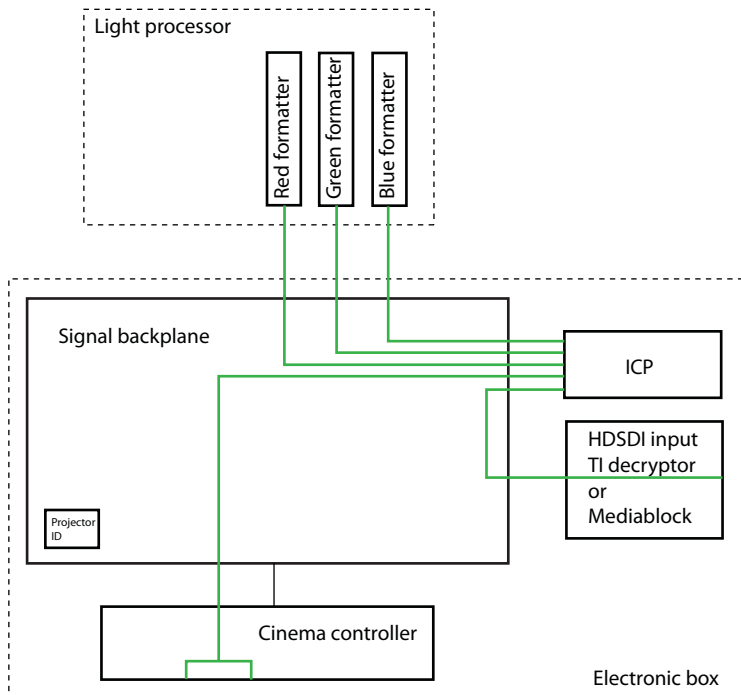

Image 2-8

The following steps happen :

- If decryption link is present; video is sent from server via HDSI cables to the projector HDSI board (or PCI express cable if media block is inserted).
- Video is decrypted on the Link decryptor board or Media Block and then sent to the Signal Backplane
- Video signal is sent to Integrated Cinema Processor
- ICP Board adds scaling, subtitle overlay, image cropping & applies all color correction. Also divides video signal into Red, Green and Blue signals.
- Formatter applies any 3D frame rate multiplication if needed and turns signal into pulses to drive or cycle DMD mirrors.
- DMD's are reflecting the light provided by the prism back to the prism and reflect it through the lens towards the screen.

2.5 Spare parts for DP2K-12C/11CX

Up to date information regarding spare parts for DP2K-12C/11CX

Barco continuously improves its service procedures for the customer. Managing spare parts is one of the key processes. The spare parts list is subject to change. No spare parts list is included in this manual to ensure that no spare parts are ordered based upon outdated information. Up to date information regarding spare parts, and much more, is available on Barco's web site <http://www.barco.com>. Go to *myBarco log in* and enter your credentials. Select your market and product and click on the product page on *Technical support*. The *Spare parts* tab becomes available.

3. PREVENTATIVE MAINTENANCE ACTIONS

Maintenance program

The maintenance program is subdivided in time frames going from monthly maintenance actions which can be done by a trained projectionist to annually and 4 yearly maintenance actions which must be done by certified service personnel who are familiar with potential hazards of the product and all product safety checks.

Overview

- Monthly maintenance actions
- Lamp change maintenance actions
- Three monthly maintenance actions
- Annually maintenance actions
- 4 yearly maintenance actions

3.1 Monthly maintenance actions

MAINTENANCE TYPE A (perform every month)



The monthly maintenance actions, listed below, may be performed by a trained projectionist who is familiar with potential hazards associated with the product.

| No. | Maintenance action | Remarks |
|-----|---|--|
| 1 | Clean all dust filters of the projector. <ul style="list-style-type: none"> • dust filter at the front of the projector (electronics). • dust filter at the top of the projector (cold mirror). • dust filter at the bottom of the projector (heat exchanger). | Use a vacuum cleaner and blow away the remaining dust away with compressed air in another room. Take care of orientation when reinstalling the cleaned filters. Frequency at which filters should be replaced is dependant on environmental conditions and the way they can be cleaned. Replace damaged filters immediately. Front dust filter, "Removing the front dust filter", page 341 , cold mirror filter, "Clean the dust filter on the top side", page 343 , . |
| 2 | Check the surface of the lens output side for dust. (it is not needed to remove the lens from the projector) | Clean the lens output side in case dust is clearly visible upon the surface. See "Cleaning the lens", page 192. Note that if the lens was removed from the projector, a home and return must be executed. See user guide of the Communicator software. |
| 3 | Check the porthole (both sides) for dust. | Clean the porthole in case dust is clearly visible upon the surface. Use an optical cloth. |

3.2 Lamp change maintenance actions

Maintenance actions at every lamp change



The maintenance actions, listed below, which are required at every lamp change may be performed by a trained projectionist who is familiar with potential hazards associated with the xenon bulb lamp.

| No. | Maintenance action | Remarks |
|-----|---|--|
| 1 | Check the UV blocker of the lamp house for dust. | Only clean the UV blocker in case dust is clearly visible upon the surface of the UV blocker (both sides). See "Cleaning the UV blocker of the Lamp House", page 122. |
| 2 | Check the reflector of the lamp house for dust. | Only clean the reflector in case dust is clearly visible upon the surface of the reflector. Take the lamp house to another room and use compressed air to blow away the dust. See "Cleaning the UV blocker of the Lamp House", page 122. |
| 3 | Visual inspection of the lamp anode and cathode connectors of the lamp house. | Replace the lamp house in case of degradation, damage, etc. See "Removal of the lamp house", page 96. |
| 4 | Visual inspection of the lamp anode and cathode cables of the lamp house. | Replace the lamp house in case of degradation, damage, etc. See "Removal of the lamp house", page 96. |

3.3 Three monthly maintenance actions

MAINTENANCE TYPE B (perform every three months)



The 3 monthly maintenance actions, listed below, may be performed by a trained projectionist who is familiar with potential hazards associated with the product.

| No. | Maintenance action | Remarks |
|-----|--|--|
| 1 | Clean the air vents/inlets of the projector: <ul style="list-style-type: none">• air inlet grid of the cold mirror fan (top side projector).• air inlet grid of the electronic compartment (front side projector).• air inlet grid of the Lamp Power Supply (bottom side projector). | Use a vacuum cleaner. |
| 2 | Clean the cabinet of the projector. (Removal overall dust accumulation on projector covers) | See cleaning procedure "Cleaning the exterior of the projector", page 340. |

3.4 Annually maintenance actions

MAINTENANCE TYPE C (perform every year)



The yearly maintenance actions, listed below, may **ONLY** be performed by certified service personnel who are familiar with potential hazards of the product and all product safety checks.

| No. Component | Maintenance action | Remarks |
|----------------------------|--|---|
| 1 Dust in general | Clean the metal mesh grid of the anode fan (inside sealed compartment). | Use a vacuum cleaner and brush. |
| 2 Dust in general | Remove all dust inside the lamp compartment. | Use a vacuum cleaner. Do NOT touch the cold mirror. |
| 3 Dust in general | Check the cold mirror for dust, burn damage, degradation, cracks, etc. | Only clean the cold mirror in case dust is clearly visible upon the surface of the cold mirror. Replace the cold mirror in case of burn damage, degradation, cracks, etc. See "Cold mirror assembly", page 123. |
| 4 Dust in general | Check the mask and the integrator entry for burn damage, degradation, cracks, etc. Remove the lamp house and look at the mask and integrator entry via the cold mirror. | Replace the integration rod and mask in case of burn damage, degradation, cracks, etc. See "Removal of the integrator rod", page 176. |
| 5 Dust in general | Open the dowser (shutter) and check the prism exit side for dust, discoloration, damage, degradation, cracks, etc. | Only clean the prism exit side in case dust is clearly visible upon the surface of prism. See "Cleaning the Prism exit side", page 156. Replace the complete Light Processor Unit in case of degradation, cracks, etc. See "Light processor assembly", page 135. |
| 6 Dust in general | Check the porthole (both sides) for dust. | Only clean the porthole in case dust is clearly visible upon the surface. Use an optical cloth. |
| 7 Dust in general | Clean the projector exterior (housing). Report on cleanliness of booth! | See cleaning procedure |
| 8 Dust in general | Check the condition (hot state) of the light pipe and prism by looking for artifacts in the projected full white and full black patterns. | If artifacts are visible diagnose the integration rod. See "Rod diagnostic", page 175. Replace the integration rod In case the integration rod causes the artifacts. See "Removal of the integrator rod", page 176. Replace the complete Light Processor Unit in case the prism causes the artifacts. See "Light processor assembly", page 135. |
| 9 Diagnostics | Check actual diagnostics after 1 hour play with black image. See user guide of the Communicator software. | Note any irregularities and follow up. Take the necessary measurements if required. |
| 10 Diagnostics | Run self tests. See user guide of the Communicator software | Note any irregularities and follow up. Take the necessary measurements if required. |
| 11 Diagnostics | Create a diagnostic package and check the log files inside the package. | Use the diagnostic package reader and note any irregularity. |
| 12 Diagnostics | Verify Link Decryptor clock. Time must be set to UTC/GMT time | Only a deviation of 15 minutes is allowed. See Communicator software. |
| 13 Software version | Check for the latest version of Barco and TI software. See user guide of the Communicator software. The latest software version can be downloaded from the secured Barco web site. | Upgrade the projector software with the latest version. See user guide of the projector toolset. |
| 14 Info-T's | Check if all Info-T's are implemented. Note that the Info-T's are listed on the secured Barco web site. | If not, implement all Info-T's and update the projector service docket. |

3. Preventative maintenance actions

| No. Component | Maintenance action | Remarks |
|----------------------------------|---|---|
| 15 Electrical connections | <p>Check the torque values/general condition of all critical electrical connections and components. Use a torque wrench to verify the torque values of the critical electrical connections listed:</p> <ul style="list-style-type: none"> Nuts (x2) of the SPG socket inside the lamp house: 9 Nm. Cathode cable nut for the lamp cathode socket: 17Nm Hexagon socket head cap screw at the lamp cathode socket : 2,5 Nm. Nuts (x4) of the LAMP OUT ports of the LPS unit: 4 Nm | Do not release the nuts to check the torque. Just verify. |
| 16 Lamp Module | Check the UV blocker of the lamp house for dust, burn damage, degradation, cracks, etc. Note that in case of a passive 3D projection system the UV blocker has an adapted 3D coating. | <p>Only clean the UV blocker in case dust is clearly visible upon the surface of the UV blocker (both sides). See page 122.</p> <p>Replace the UV blocker in case of burn damage, degradation, cracks, etc.</p> |
| 17 Lamp Module | Check the reflector of the lamp house for dust, degradation, cracks, etc. | <p>Only clean the reflector in case dust is clearly visible upon the surface of the reflector. Take the lamp house to another room and use compressed air to blow away the dust from the reflector. See page 122.</p> <p>Replace the reflector in case of burn damage, degradation, cracks, etc. See "Replacement of the lamp reflector", page 118.</p> |
| 18 Lamp Module | Visual inspection of the lamp anode and cathode connectors of the lamp house. | Replace the lamp house in case of degradation, damage, etc. See "Removal of the lamp house", page 96. |
| 19 Lamp Module | Visual inspection of the lamp anode and cathode cables of the lamp house. | Replace the lamp house in case of degradation, damage, etc. See "Removal of the lamp house", page 96. |
| 20 Lamp Module | Check motors (motorized lamp house) and manual adjustments. Lubricate if needed. | |
| 21 Lamp Module | Check the positional integrity of automatic lamp alignment/CLO. | Perform auto alignment. Manual adjustment afterwards should not improve light output. |
| 22 Lens holder | Check the lens holder shift functionality (up/down & left/right). Lubricate where needed. | Use the local keypad and the Communicator software to shift. |
| 23 Lens holder | Check the positional integrity of motorized adjustments by switching Macro's. | Verify correct alignment on screen between flat and scope. |
| 24 Lens holder | Check the focus uniformity. | Adjust the lens holder (Scheimpflug) ONLY if needed. See "Scheimpflug adjustment", page 199. |
| 25 Lens | Check the optic surfaces of the lens input and output for dust. | Only clean the input and/or output side in case dust is clearly visible upon the surfaces. Use an optical cloth. Note that a lens removal requires a home and return action. See user guide of the Communicator software. |
| 26 Lens | Check the lens Zoom & Focus motors. | Use the local keypad and the Communicator software to Zoom and to Focus. |
| 27 Shutter (Dowser) | Check the functionality of the Dowser (shutter). Loose components, wear and tear. | <p>Use the local keypad and the Communicator software to Open and Close the shutter.</p> <p>Replace the dowser (shutter) if needed. See "Replacement of the dowser (shutter)", page 152.</p> |
| 28 Electronic boards | <p>Check the general condition of the electronic boards: Status LED's, dust, connections, etc.</p> <p>Boards to check: LPS, SMPS, Fan Control Board, ICP Board, Cinema Controller Board, HD-SDI Board</p> | Blow out dust. |
| 29 Security | Check the Tamper Switch Activation Report and Security Logs for security infringements. | Report if intruded. |
| 30 Security | Verify if the Dallas key is present and working. | Report if missing, lost or damaged. |

3. Preventative maintenance actions

| No. Component | Maintenance action | Remarks |
|-----------------------|---|---|
| 31 Air Extraction | Check customer air extraction system for adequate extraction. | The air extraction system must be capable of removing minimum 6,65 m ³ /min or 235 CFM per installed DP2K-12C/11CX digital projector. This must be measured at EACH individual projector head exhaust stack. |
| 32 Documenta- tion | Check if the projector manuals are present and up-to-date. | Download current manual version from www.MyBarco.com . |
| 33 Documenta- tion | Update projector service docket. | List all maintenance actions and remarks. |

3.5 4 yearly maintenance actions

MAINTENANCE TYPE D (perform every four years)



The 4 yearly maintenance actions, listed below, may **ONLY** be performed by certified service personnel who are familiar with potential hazards of the product and all product safety checks.

| No. | Maintenance action | Remarks |
|-----|---|---|
| 1 | Check the lamp fans: vibrations, noise, speed, etc. (speeds: via diagnostics) | Replace if needed. See "Fan replacement procedure", page 319. |

4. TROUBLESHOOTING

4.1 Troubleshooting checklist

Code 5003: "light sensor - no communication" (Error)

| Situation | Solution |
|--|---|
| No communication with the Light Sensor Module (CLO). | <ol style="list-style-type: none"> Reboot the projector: <ol style="list-style-type: none"> Turn off the Lamp and cool down the Lamp for at least 1 minute if hot. Switch off the power of the unit and wait for at least 15 seconds. Switch on the power of the unit and respect normal startup procedure. Check if the wire unit (reference 1 of image 4-1) is connected with the CLO module and with the Signal Backplane. Note: To access the Signal Backplane the top cover of the Card Cage has to be removed. Removing the top cover will lead to an authorization request upon startup. If the problem remains, replace the CLO module. See chapter "Replacement of the Lamp Info module", page 113. |

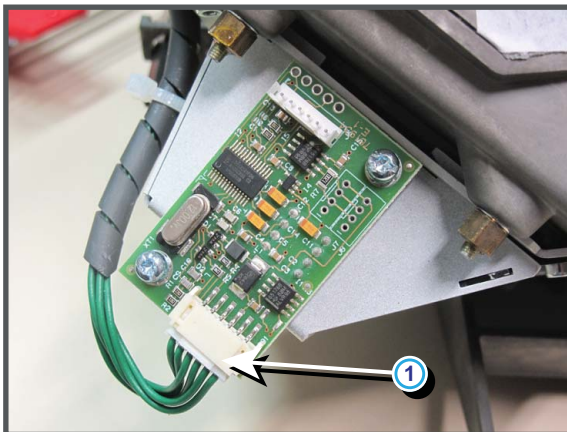
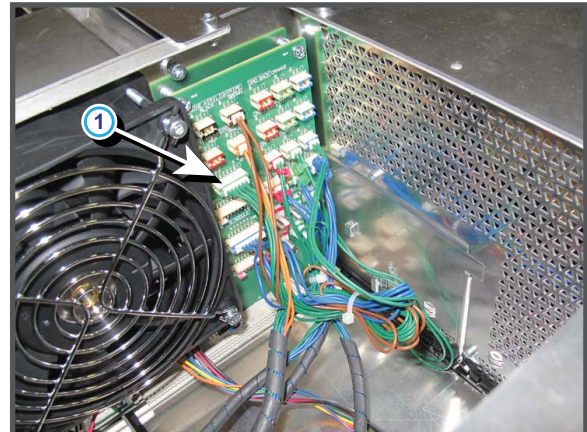

Image 4-1



Code 5004: "lamp - no communication" (Error)

| Situation | Solution |
|---|--|
| Lamp House is not correctly installed. | Check if the Lamp House is properly installed. Ensure that the three fixation screws (reference 2 of image 4-2) of the Lamp House are fastened. |
| Wrong Lamp House detected in lamp compartment of the projector. | Replace the Lamp House with a compatible Lamp House for this projector. |
| No communication with the Lamp House. | <ol style="list-style-type: none"> Check if the blue socket (reference 3 of image 4-3) of the Lamp House is not damaged. Check if the blue socket (reference 4 of image 4-3) in the lamp compartment is not damaged (front side and back side). Check if the wire unit (reference 5 of image 4-3) is connected with the blue socket in the lamp compartment and is plugged in its socket on the Signal Backplane (reference 6 image 4-3). Replace the Integrated Cinema Controller board. See "Removing a board in the card cage", page 221 Replace the Signal Backplane. See "Replacement of the signal back plane", page 239. |

4. Troubleshooting

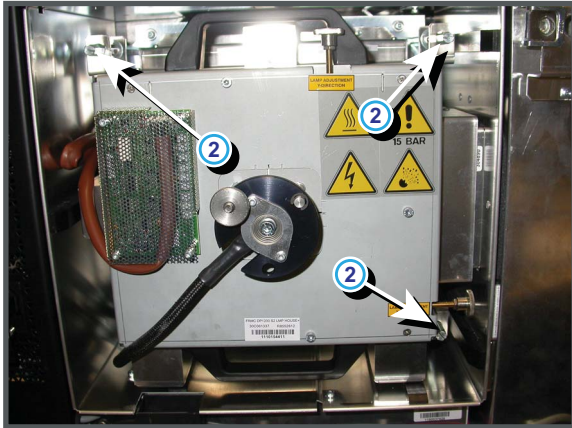

Image 4-2
Lamp fixation

- 2 Lamp House fixation screws.

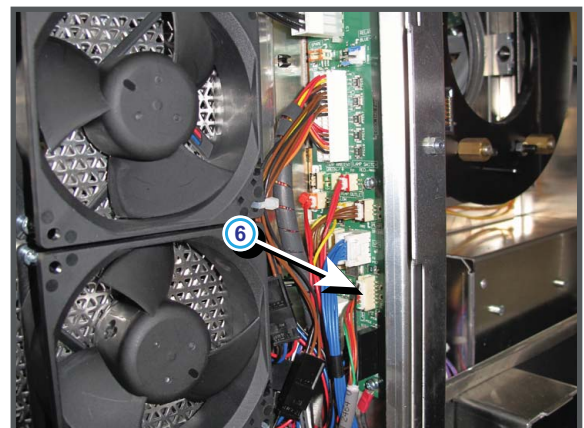
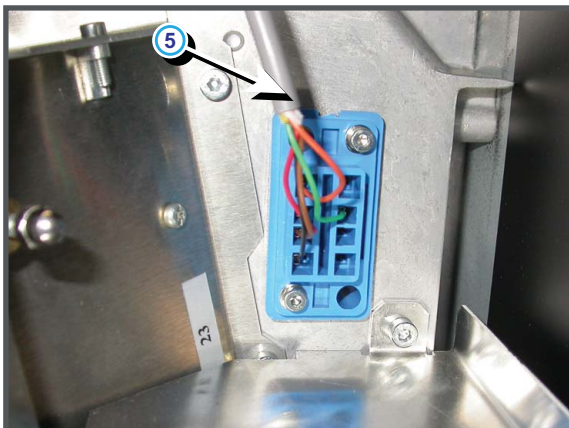
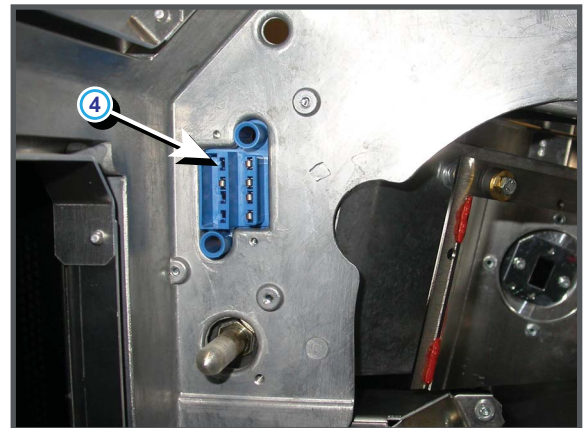
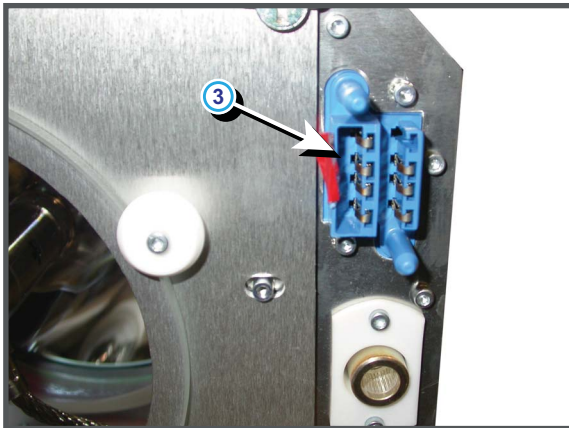

Image 4-3
Lamp connections

- 3 Blue socket connection Lamp Info Module of the Lamp House.
4 Blue socket inside Lamp compartment (front view).
5 Wire unit for connection with blue socket (back side).
6 Lamp info module cable connection to signal backplane

Code 5005: “lamp power supplies - communication failed” (Error)

| Situation | Solution |
|--|--|
| Mains power interruption of the LPS units. None of the diagnostic LEDs of the LPS units lit up. Note that the projector electronics remain operational in case an UPS unit is used (This situation can not appear in case no UPS unit is used) | Check the voltage of the mains power (commercial net, reference 1 of image 4-4) which enters the backside of the projector to supply the LPS units. |
| Power cables disconnected from the Mains Input sockets of the LPS units. | Check if the power cables (reference 2 of image 4-4) are connected with the LPS units. |
| LPS communication cable disconnected from the CTLB-IN port of the first LPS unit in the LPS rack. | Check if the LPS communication cable (reference 4 of image 4-5) is connected with the CTLB-IN port of the first LPS unit in the LPS rack of the projector. |
| Disconnected blue LPS cascade wire unit (CTLB-IN / CTLB-OUT). | Reconnect the blue wire unit (reference 5 image 4-5) between the “CTLB-IN” and “CTLB-OUT” sockets of the LPS units. |
| LPS communication cable disconnected from the Signal Backplane. | Check if the LPS communication cable (reference 7) of image 4-6 is connected with the Signal Backplane. |
| Malfunction of one of the LPS modules. The red LED “ERR” of the malfunction LPS module lit up. | Replace the malfunction LPS unit. See chapter "Lamp power supply", page 291 or "Lamp power supply (single module)", page 299. |

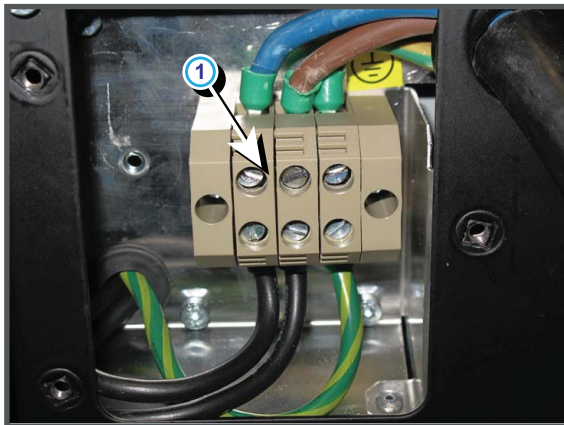

Image 4-4
Power connection

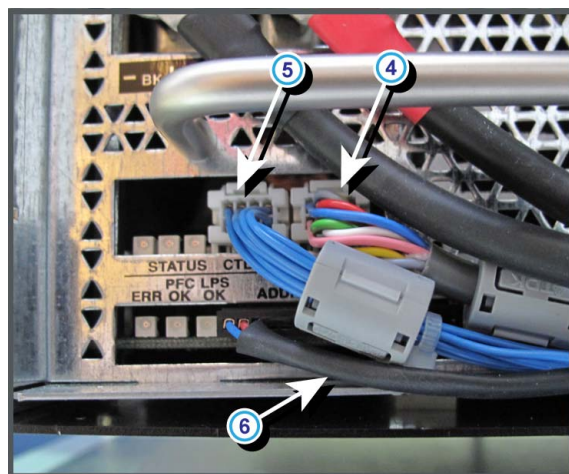
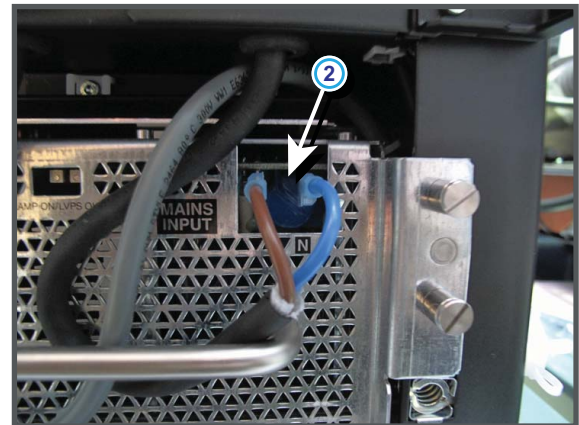

Image 4-5
Data connection LPS side

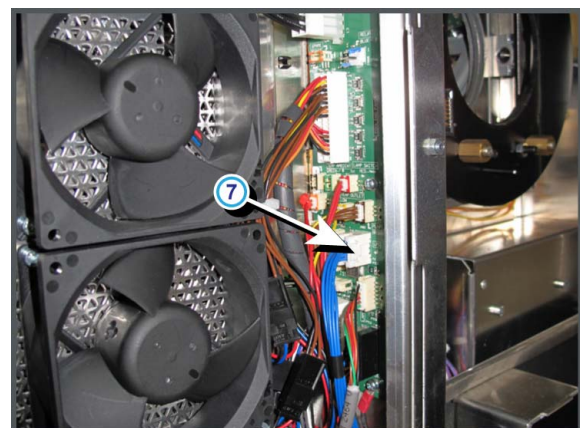

Image 4-6
LPS data connection Signal backplane

Code 5020: “system - read projector identification failed” (Error)

| Situation | Solution |
|---|--|
| Cinema Controller failure. | Re-seat/replace the Cinema Controller board. |
| Corrupt or invalid Projector ID card (reference 1 of image 4-7) | Contact Barco for further actions. |

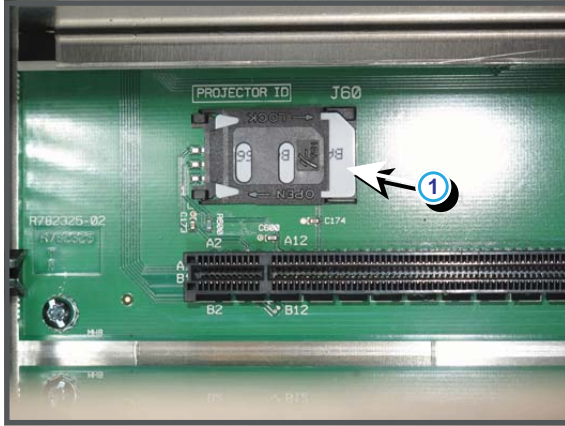

Image 4-7
Projector identification

Code 5042: “cold mirror fan - speed too low” (Error)

| Situation | Solution |
|--|---|
| Wire unit (reference 1 image 4-8) of the Cold Mirror fan (reference 2 image 4-8) disconnected. | Remove the left cover of the projector and check the connection of the wire unit of the fan below the Cold Mirror. |
| Wire unit of the fan units (reference 5 image 4-8) disconnected from the Signal Backplane. | Remove the front cover and front dust filter from the projector and check if the wire unit (reference 5 image 4-8) is inserted in the Signal Backplane. |
| Blocked fan (reference 2 image 4-8). | Unblock the fan. Ensure that the fan can turn freely. |
| Damaged wire unit. | Check if the wire unit of the fan is not damaged. Repair if possible, otherwise replace with new one. |
| Malfunction Fan Control board. | Replace the Fan Control board. See "Removing a board in the card cage", page 221. |
| Fan end of life. | Replace the fan. See chapter "Cold mirror fan", page 335. |

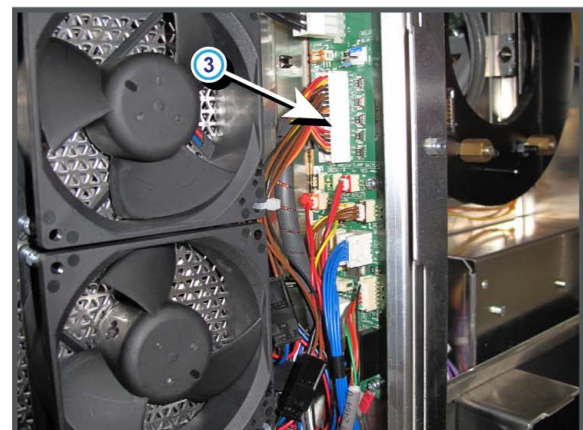
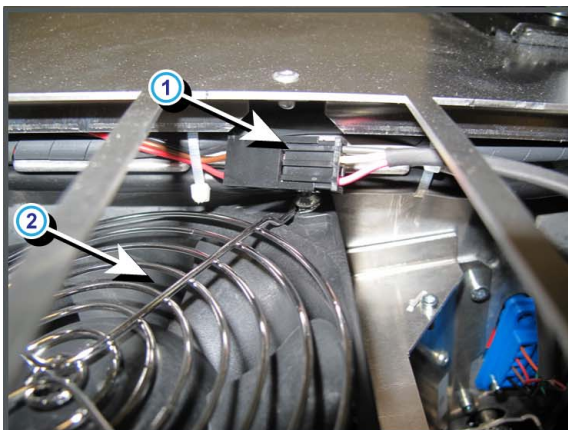

Image 4-8
Cold mirror fan connection

Code 5043: “cold mirror fan - speed low” (Warning)

| Situation | Solution |
|--------------------------------------|---|
| Blocked fan (reference 2 image 4-8). | Unblock the fan. Ensure that the fan can turn freely. |

| Situation | Solution |
|--------------------------------|---|
| Damaged wire unit. | Check if the wire unit of the fan is not damaged. Repair if possible, otherwise replace with new one. |
| Malfunction Fan Control board. | Replace the Fan Control board. See "Removing a board in the card cage", page 221. |
| Fan end of life. | Replace the fan. See chapter "Cold mirror fan", page 335. |

Code 5053: "engine fan - speed low " (Warning)

| Situation | Solution |
|--------------------------------------|---|
| Blocked fan (reference 1 image 4-9). | Unblock the fan. Ensure that the fan can turn freely. |
| Damaged wire unit. | Check if the wire unit of the fan is not damaged. Repair if possible, otherwise replace with new one. |
| Malfunction Fan Control board. | Replace the Fan Control board. See "Removing a board in the card cage", page 221. |
| Fan end of life. | Replace the fan. See chapter "Light processor compartment fan", page 324. |

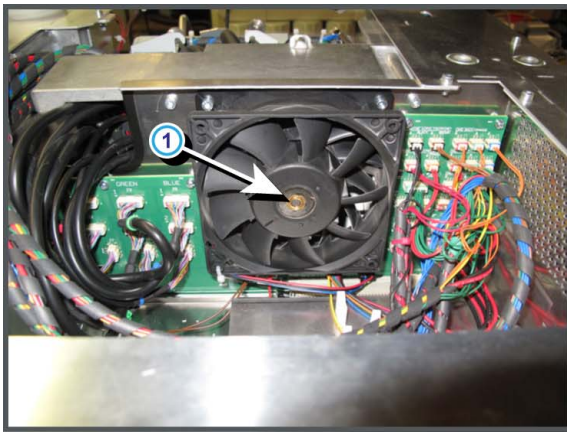
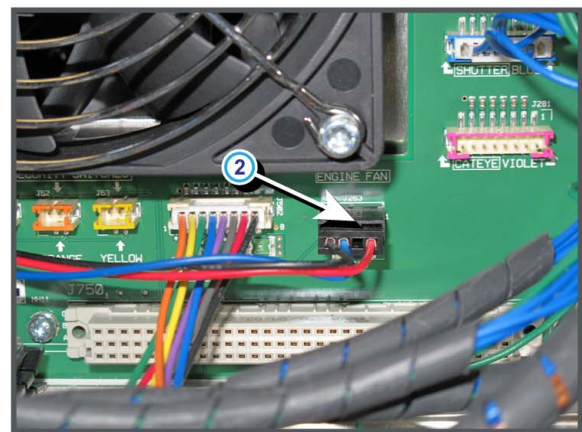

Image 4-9
Light processor compartment fan

**Code 5072: "lamp anode fan - speed too low" (Error)**

| Situation | Solution |
|--|---|
| Wire unit (reference 1 image 4-10) of the Anode Fan is disconnected. | Remove the left side cover of the projector and check the connection of the Anode Fan. |
| Wire unit (reference 3 image 4-10) of the fan units is disconnected from the Signal Backplane. | Remove the front cover and front dust filter from the projector and check if the wire unit (reference 53 image 4-10) is inserted in the Signal Backplane. |
| Blocked Anode Fan (reference 2 image 4-10). | Check if the Anode Fan is not blocked. Ensure that the Anode Fan can turn freely. |
| Damaged wire unit. | Check if the wire unit of the Anode Fan is not damaged. Repair if possible, otherwise replace with new one. |
| Malfunction Fan Control board. | Replace the Fan Control board. See "Removing a board in the card cage", page 221. |
| Anode fan (reference 2 image 4-10) end of life. | Replace the Anode Fan. |

4. Troubleshooting

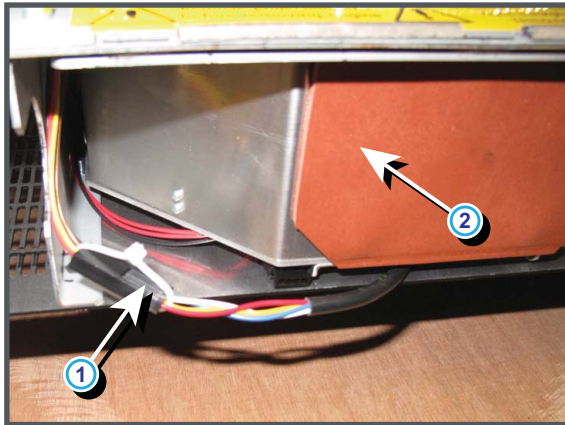
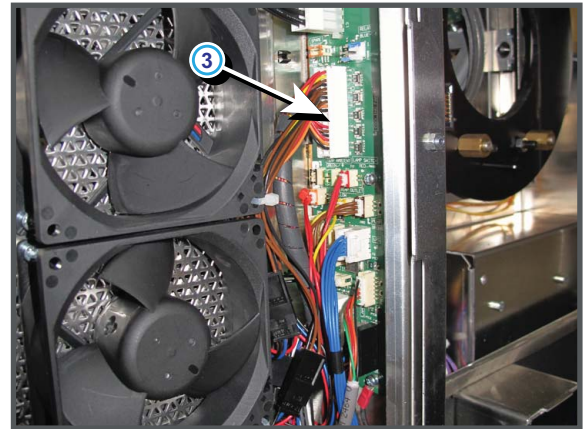

Image 4-10
Anode fan connections



Code 5073: “lamp anode fan - speed low” (Warning)

| Situation | Solution |
|--|---|
| Wire unit (reference 1 image 4-11) of the Anode Fan is disconnected. | Remove the left side cover of the projector and check the connection of the Anode Fan. |
| Wire unit (reference 3 image 4-11) of the fan units is disconnected from the Signal Backplane. | Remove the front cover and front dust filter from the projector and check if the wire unit (reference 53 image 4-11) is inserted in the Signal Backplane. |
| Blocked Anode Fan (reference 2 image 4-11). | Check if the Anode Fan is not blocked. Ensure that the Anode Fan can turn freely. |
| Damaged wire unit. | Check if the wire unit of the Anode Fan is not damaged. Repair if possible, otherwise replace with new one. |
| Malfunction Fan & Motor Control board. | Replace the Fan & Motor Control board. See "Removing a board in the card cage", page 221. |
| Anode fan (reference 2 image 4-11) end of life. | Replace the Anode Fan. See "Lamp anode fan", page 332. |

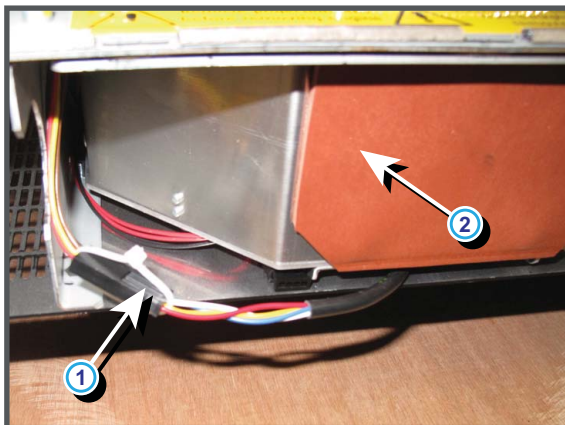
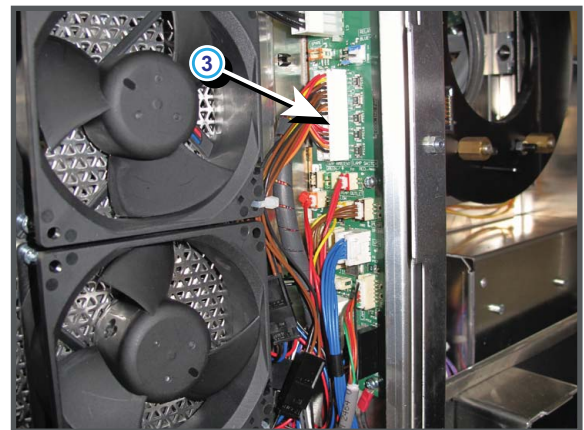

Image 4-11
Anode fan connections



Code 5082: “lamp cathode fan - speed too low” (Error)

| Situation | Solution |
|--|--|
| Wire unit (reference 1 image 4-12) of the Cathode Fan is disconnected. | Remove the left side cover of the projector and check the connection of the Cathode Fan. |

| Situation | Solution |
|--|--|
| Wire unit (reference 3 image 4-12) of the fan units is disconnected from the Signal Backplane. | Remove the front cover and front dust filter from the projector and check if the wire unit (reference 3 image 4-12) is inserted in the Signal Backplane. |
| Blocked Cathode Fan (reference 2 image 4-12). | Check if the Cathode Fan is not blocked. Ensure that the Cathode Fan can turn freely. |
| Damaged wire unit. | Check if the wire unit of the Cathode Fan is not damaged. Repair if possible, otherwise replace with new one. |
| Malfunction Fan Control board. | Replace the Fan Control board. See "Removing a board in the card cage", page 221. |
| Cathode fan (reference 1 image 4-12) end of life. | Replace the Cathode Fan. See "Lamp cathode fan", page 327. |

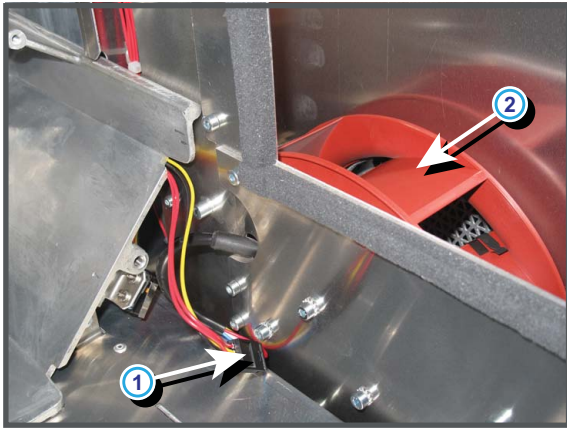
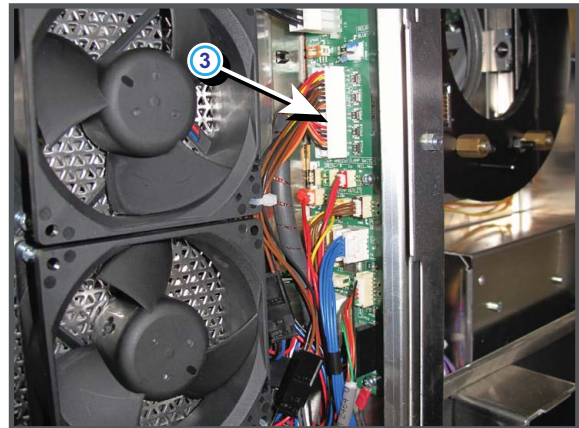

Image 4-12
Cathode fan connections



Code 5083: "lamp cathode fan - speed low" (Warning)

| Situation | Solution |
|---|---|
| Blocked Cathode Fan (reference 2 image 4-12). | Check if the Cathode Fan is not blocked. Ensure that the Cathode Fan can turn freely. |
| Damaged wire unit. | Check if the wire unit of the Cathode Fan is not damaged. Repair if possible, otherwise replace with new one. |
| Malfunction Fan Control board. | Replace the Fan Control board. See "Removing a board in the card cage", page 221. |
| Cathode fan (reference 1 image 4-12) end of life. | Replace the Cathode Fan. See "Lamp cathode fan", page 327. |

Code 5103: "smps fan 1 (left side) - speed low" (Warning)

| Situation | Solution |
|--|---|
| Blocked fan. (reference 1 image 4-13) | Unblock the fan. Ensure that the fan can turn freely. |
| Damaged wire unit. (reference 2 & 5 of image 4-13) | Check if the wire unit of the fan is not damaged. Repair if possible, otherwise replace with new one. |
| Malfunction Fan Control board. | Replace the Fan Control board. See "SMPS compartment fans", page 322. |
| Fan end of life. | Replace the fan. See "SMPS compartment fans", page 322. |

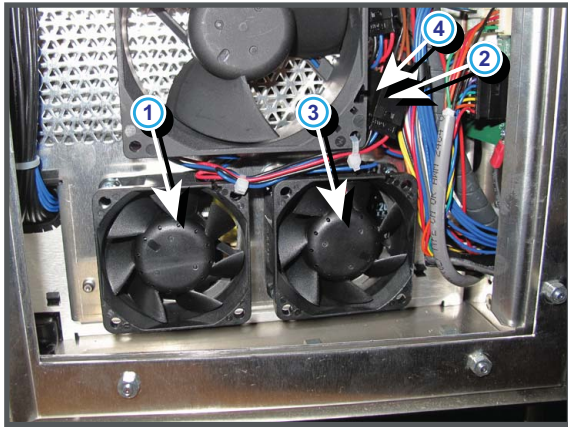
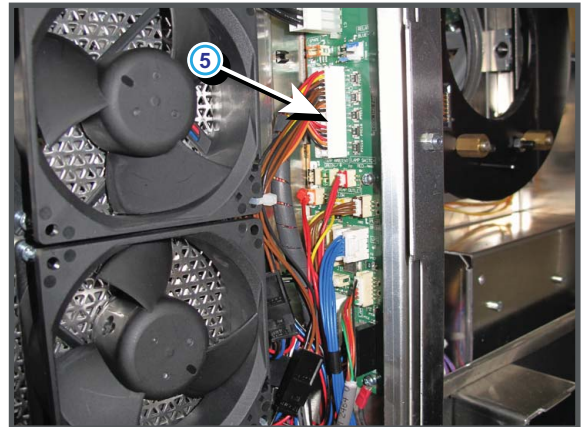

Image 4-13
SMPS fans connections



Code 5113: “smps fan 2 (right side) - speed low” (Warning)

| Situation | Solution |
|--|---|
| Blocked fan. (reference 4 of image 4-13) | Unblock the fan. Ensure that the fan can turn freely. |
| Damaged wire unit. (reference 3 & 5 of image 4-13) | Check if the wire unit of the fan is not damaged. Repair if possible, otherwise replace with new one. |
| Malfunction Fan Control board. | Replace the Fan Control board. See "SMPS compartment fans", page 322. |
| Fan end of life. | Replace the fan. See "SMPS compartment fans", page 322. |

Code 5123: “lamp rear fan - speed low” (Warning)

| Situation | Solution |
|--|---|
| Blocked fan. (reference 1 image 4-14) | Unblock the fan. Ensure the fan can turn freely. |
| Damaged wire unit of the fan. (reference 2 & 3 image 4-14) | Check if the wire unit of the fan is not damaged. Repair if possible, otherwise replace with new one. |
| Fan end of life. | Replace the fan. |
| Malfunction Fan Control board. | Replace the Fan Control board. See "Lamp Info Module fan", page 337. |
| Fan end of life. | Replace the fan. See "SMPS compartment fans", page 322. |

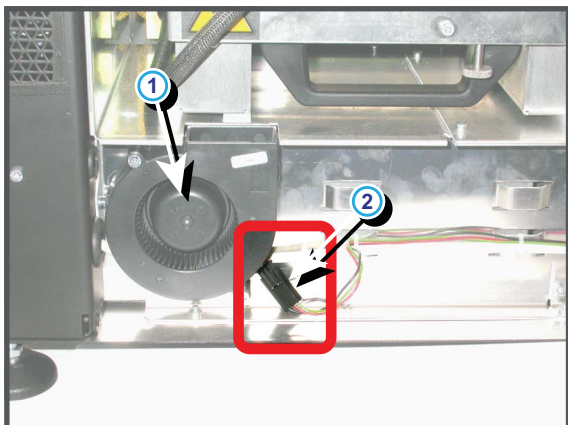
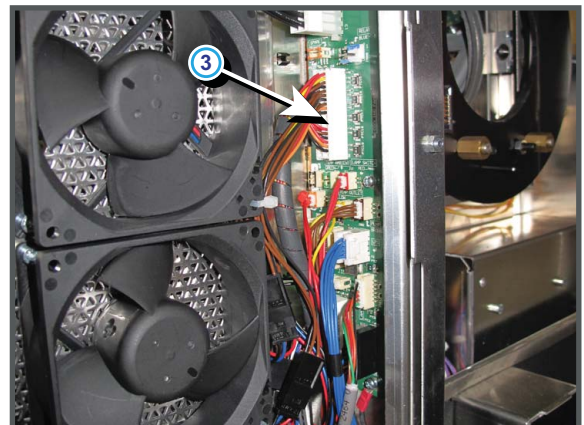

Image 4-14
Lamp rear fan connections



Code 5143: “electronics fan 1 (top side) - speed low” (Warning)

| Situation | Solution |
|---------------------------------------|---|
| Blocked fan. (reference 1 image 4-15) | Unblock the fan. Ensure that the fan can turn freely. |

| Situation | Solution |
|--|---|
| Damaged wire unit. (reference 2 & 5 of image 4-15) | Check if the wire unit of the fan is not damaged. Repair if possible, otherwise replace with new one. |
| Malfunction Fan Control board. | Replace the Fan Control board. See "Removing a board in the card cage", page 221. |
| Fan end of life. | Replace the fan. See "Card cage fans", page 320. |

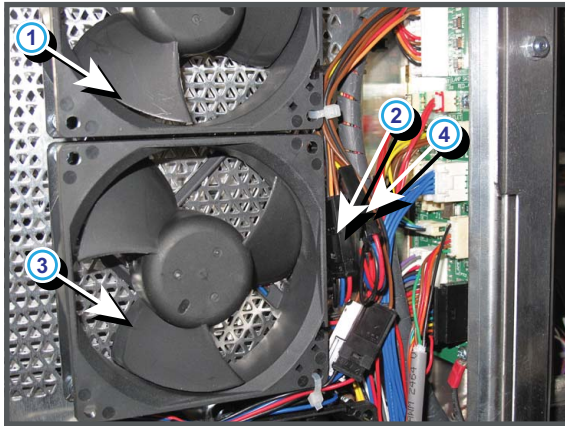
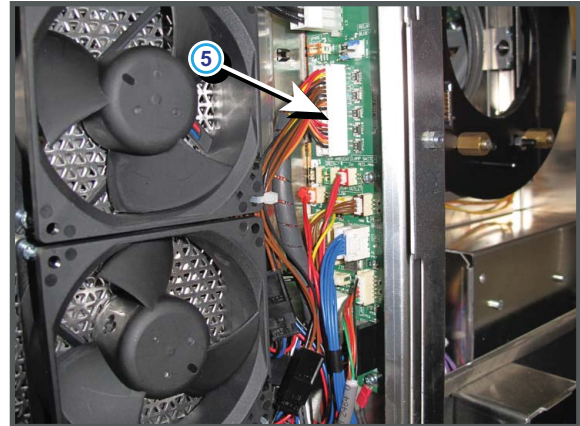

Image 4-15
Card cage fans



Code 5160: "engine switch - not ok" (Error)

| Situation | Solution |
|--|---|
| The Light Processor Unit is not correctly installed. | Check if the Light Processor Unit is properly installed. Ensure that both fixation screws at the foot of the Light Processor Unit are fastened. |
| Switch disconnected (reference 1 on image 4-16) on Signal Backplane. | Check connection of engine switch at the signal backplane, if connections are OK, measure switch at connector for continuity. |
| Damaged switch. | Remove the Light Processor Unit and check that switch is not damaged. The switch is located behind left hand side set pin which guides the engine into place. Replace switch if needed. |
| Malfunction Fan Control board. | Replace the Fan Control board. See "Removing a board in the card cage", page 221. |

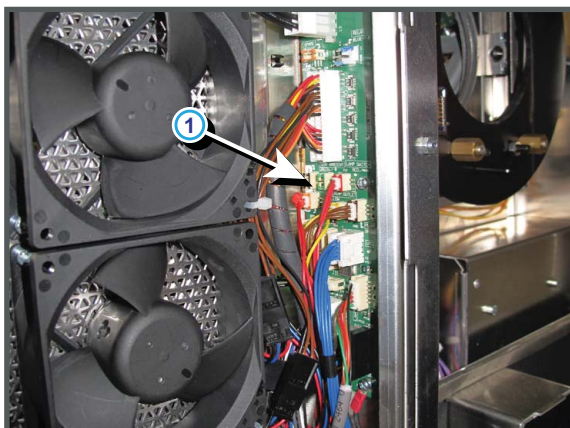

Image 4-16
Light processor switch connection

Code 5180: "lamp house - not connected" (Error)

| Situation | Solution |
|---|---|
| The lamp house is not correctly installed in its compartment. | Check if the lamp house is properly installed. Ensure that the three fixation screws (reference 1 image 4-17) of the lamp house are fastened. |
| Switch damaged (reference 2 image 4-17). | Check lamp house detection switch for damage. The switch is located at the bottom right corner. Replace if damaged. |
| Switch disconnected (reference 3 image 4-17). | Check connection of lamp house detection switch at the Signal Backplane, if connections are OK then measure switch cable for continuity. |

4. Troubleshooting

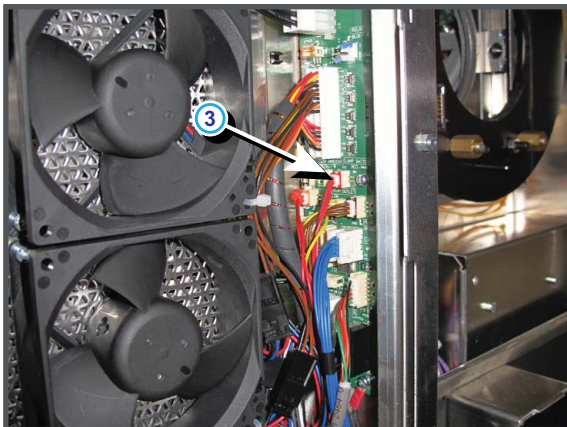
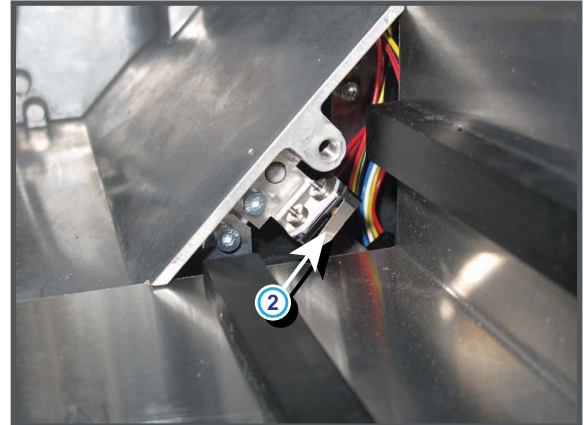
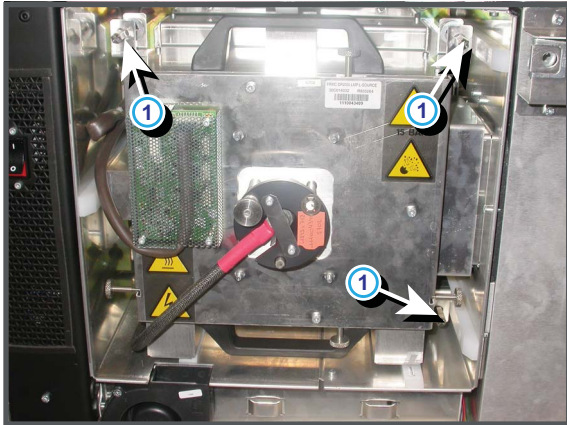

Image 4-17
Lamp house switch

Code 5191: “prism switch - warning (lens probably touches prism)” (Warning)

| Situation | Solution |
|---|---|
| Lens is touching the sensor (reference PR of image 4-18) on the prism. Maximum lens shift position reached. | Shift the lens upwards and/or to the left. |
| Defect prism sensor. | Remove lens and reboot projector, if warning appears again then the prism sensor is defective and needs to be replaced. |

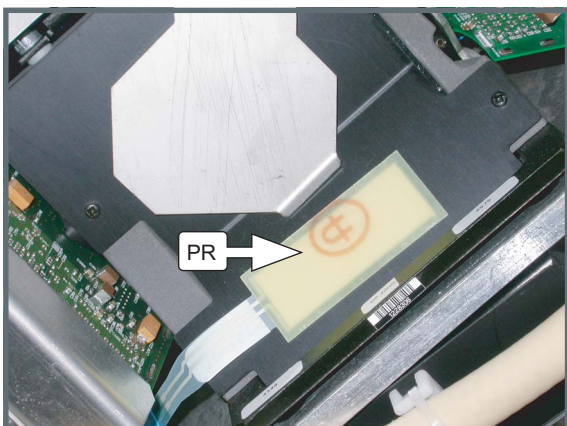

Image 4-18
PR Prism switch.

Code 5230: “lens zoom position - requested target not reached” (Warning)

| Situation | Solution |
|------------------------|--|
| Manual lens installed. | Replace the manual lens with a motorized lens. |

| Situation | Solution |
|---|---|
| The activated lens file does not correspond with the lens mounted on the projector. | Activate a lens file which does correspond with the mounted lens or mount an other lens which corresponds with the lens file you want to activate. |
| Corrupt lens file. | Delete the lens file and program correct lens type into communicator under Advanced/lens parameters and recreate a new lens file. Tip: perform a "Lens Homing" before creating a new lens file. Otherwise, if the lens is removed the existing lens file becomes useless. Setup all new lens files away from the maximum limitation of the lens zoom. It is possible that the lens file was originally created at the maximum or minimum zoom capabilities of the lens zoom. |
| The final lens position lays very close to the mechanical limits which disable the motorized lens position. | Position the lens manually, or reposition the projector so that the lens position lies further away from the mechanical limits, or try to use another lens which range is more suitable. Setup all new lens files away from the maximum limitation of the lens zoom. It is possible that lens file was originally created at the maximum or minimum zoom capabilities of the lens zoom. Program correct lens type into communicator under Advanced/lens parameters and recreate the lens files. |
| Disconnected wire units (reference 1 image 4-19) of the zoom motor of the motorized lens. | Remove the front cover of the projector and check if all wire units at the left bottom of the lens holder are connected. |
| Disconnected wire unit, of the lens zoom/shift signals, from the Signal Backplane. | Remove the front cover and front dust filter from the projector and check if the wire unit (reference 4 image 4-19) is inserted in the Signal Backplane (white plug behind blue wires). |
| Malfunction Fan Control board. | Replace the Fan Control board. See "Removing a board in the card cage", page 221. |
| Malfunction zoom motor of the lens. | Use the local keypad to zoom the image on the screen. If unsuccessful, replace the motorized lens. |
| Malfunction Signal Backplane (bad connection). | Replace the Signal Backplane. See "Replacement of the signal back plane", page 239. |
| Malfunction SMPS board which supplies power to the lens. | Replace the SMPS board. See "Replacement of the Switched Mode Power Supply", page 289. |

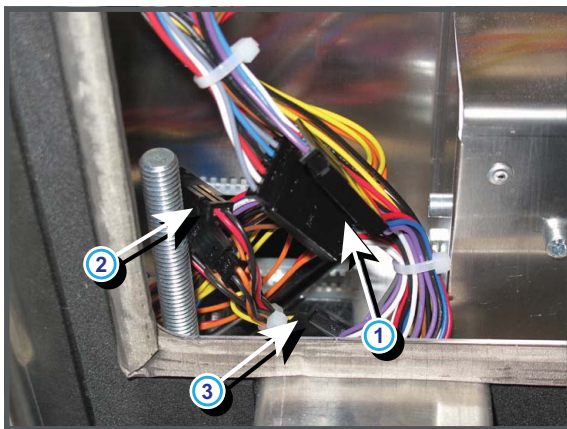
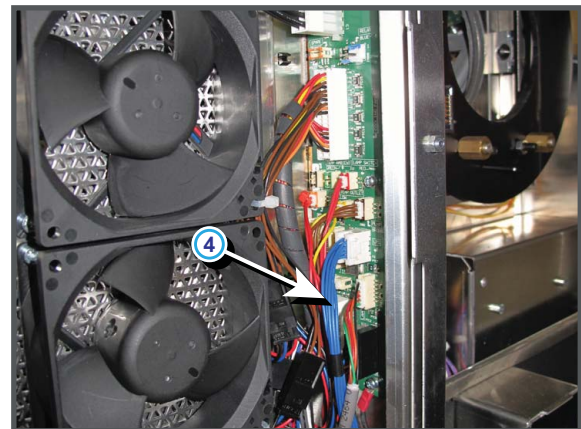

Image 4-19
Lens connections



Code 5231: "lens focus position - requested target not reached" (Warning)

| Situation | Solution |
|---|---|
| The activated lens file does not correspond with the lens mounted on the projector. | Activate a lens file which does correspond with the mounted lens or mount an other lens which correspond with the lens file you want to activate. |
| Corrupt lens file. | Delete the lens file and program correct lens type into communicator under Advanced/lens parameters and recreate a new lens file. Tip: perform a "Lens Homing" before creating a new lens file. Otherwise, if the lens is removed the existing lens file becomes useless. Setup all new lens files away from the maximum limitation of the lens zoom. It is possible that the lens file was originally created at the maximum or minimum zoom capabilities of the lens zoom. |
| The final lens position lays very close to the mechanical limits which disable the motorized lens position. | Position the lens manually, or reposition the projector so that the lens position lays further away from the mechanical limits, or try to use another lens which range is more suitable. Setup all new lens files away from the maximum limitation of the lens zoom. It is possible that lens file was originally created at the maximum or minimum zoom capabilities of the lens zoom. Program correct lens type into communicator under Advanced/lens parameters and recreate the lens files. |

4. Troubleshooting

| Situation | Solution |
|--|--|
| Wire unit (reference 1 image 4-19) of the lens focus signals disconnected from the Signal Backplane. | Remove the front cover and front dust filter from the projector and check if the wire unit (reference 1 image 4-19) is inserted in the Signal Backplane. |
| Disconnected wire unit of the Signal backplane. | Remove the front cover of the projector and check if the wire unit (reference 4 image 4-19) is connected with the Signal backplane. |
| Malfunction Fan Control board. | Replace the Fan Control board. See "Removing a board in the card cage", page 221. |
| Malfunction focus motor of the lens. | Use the local keypad to focus the image on the screen. If unsuccessful, replace the motorized lens. |
| Malfunction Signal Backplane (bad connection). | Replace the Signal Backplane. See "Replacement of the signal back plane", page 239. |
| Malfunction SMPS board which supplies power to the lens. | Replace the SMPS board. See "Replacement of the Switched Mode Power Supply", page 289. |

Code 5232: "lens horizontal shift position - requested target not reached" (Warning)

| Situation | Solution |
|---|---|
| The activated lens file does not correspond with the lens mounted on the projector. | Activate a lens file which does correspond with the mounted lens or mount an other lens which correspond with the lens file you want to activate. |
| Corrupt lens file. | Delete all current lens files and create new lens files. Note that each time the lens is removed new lens files has to be created. Setup all new lens files away from the maximum limitation of the lens zoom. It is possible that lens file was originally created at the maximum or minimum zoom capabilities of the lens zoom. Program correct lens type into communicator under Advanced/lens parameters and recreate the lens files. |
| The final lens position lays very close to the mechanical limits which disable the motorized lens position. | Position the lens manually, or reposition the projector so that the lens position lays further away from the mechanical limits, or try to use another lens which range is more suitable. Setup all new lens files away from the maximum limitation of the lens zoom. It is possible that lens file was originally created at the maximum or minimum zoom capabilities of the lens zoom. Program correct lens type into communicator under Advanced/lens parameters and recreate the lens files. |
| Disconnected wire unit of the horizontal shift motor of the motorized lens holder. | Remove the front cover of the projector and check if the wire unit is connected with the shift motor. See reference 1 image 4-20. |
| Disconnected wire unit on the Signal Backplane | Remove the front cover of the projector and check if the wire unit (reference 2 image 4-20) is connected with the Signal backplane. |
| Malfunction Fan Control board. | Replace the Fan Control board. See "Removing a board in the card cage", page 221. |
| Malfunction shift motor of the motorized lens holder. | Use the local keypad to shift the image on the screen horizontally. If unsuccessful, replace the horizontal shift motor of the motorized lens holder. |
| Malfunction Signal Backplane (bad connection). | Replace the Signal Backplane, see "Replacement of the signal back plane", page 239. |
| Malfunction SMPS board which supplies power to the lens. | Replace the SMPS board. See "Replacement of the Switched Mode Power Supply", page 289. |

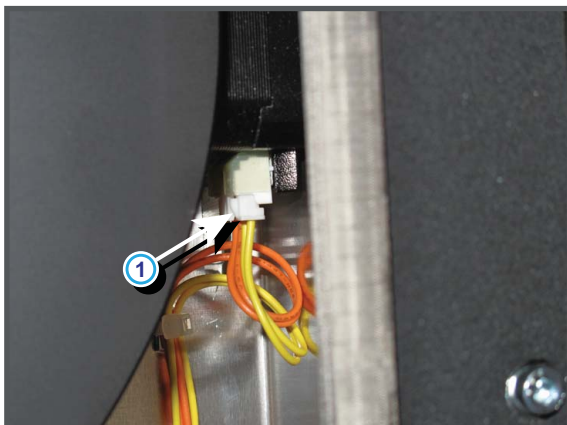
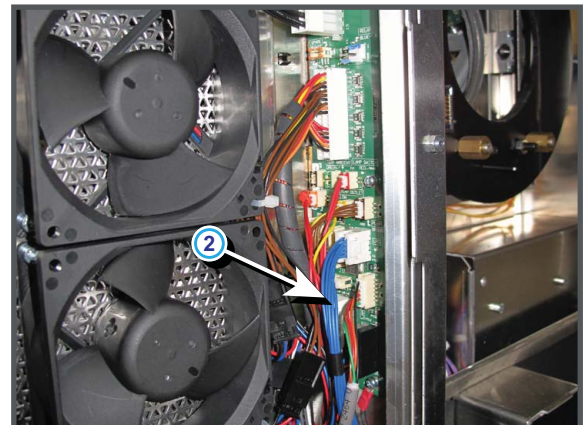

Image 4-20
Horizontal lens shift connection



Code 5233: “lens vertical shift position - requested target not reached” (Warning)

| Situation | Solution |
|---|---|
| The activated lens file does not correspond with the lens mounted on the projector. | Activate a lens file which does correspond with the mounted lens or mount an other lens which correspond with the lens file you want to activate. |
| Corrupt lens file. | Delete all current lens files and create new lens files. Note that each time the lens is removed new lens files has to be created. Setup all new lens files away from the maximum limitation of the lens zoom. It is possible that lens file was originally created at the maximum or minimum zoom capabilities of the lens zoom. Program correct lens type into communicator under Advanced/lens parameters and recreate the lens files. |
| The final lens position lays very close to the mechanical limits which disable the motorized lens position. | Position the lens manually, or reposition the projector so that the lens position lies further away from the mechanical limits, or try to use another lens which range is more suitable. Setup all new lens files away from the maximum limitation of the lens zoom. It is possible that lens file was originally created at the maximum or minimum zoom capabilities of the lens zoom. Program correct lens type into communicator under Advanced/lens parameters and recreate the lens files. |
| Disconnected wire unit of the vertical shift motor of the motorized lens holder. | Remove the front cover of the projector and check if the wire unit is connected with the shift motor. See reference 1 image 4-21. |
| Disconnected wire unit on the Signal Backplane | Remove the front cover of the projector and check if the wire unit (reference 2 image 4-21) is connected with the Signal backplane. |
| Malfunction Fan Control board. | Replace the Fan Control board. See "Removing a board in the card cage", page 221. |
| Malfunction shift motor of the motorized lens holder. | Use the local keypad to shift the image on the screen vertically. If unsuccessful, replace the vertical shift motor of the motorized lens holder. |
| Malfunction Signal Backplane (bad connection). | Replace the Signal Backplane, see "Replacement of the signal back plane", page 239. |
| Malfunction SMPS board which supplies power to the lens. | Replace the SMPS board. See "Replacement of the Switched Mode Power Supply", page 289. |

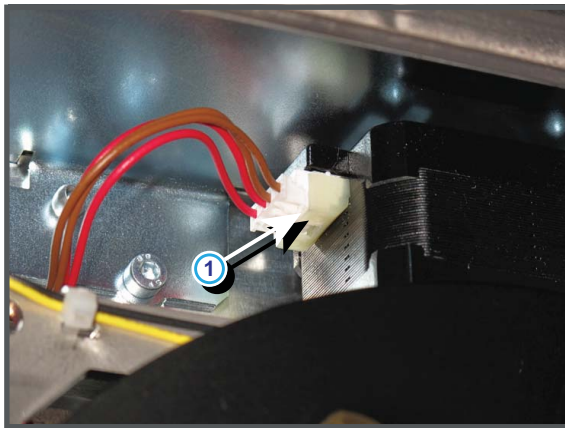
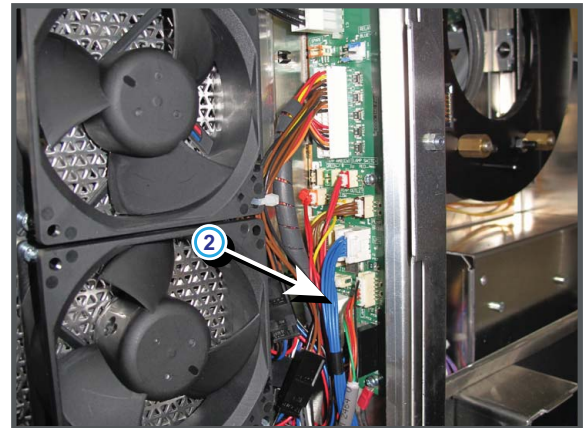

Image 4-21
Vertical lens shift connection

**Code 5253: “dmd red fan - speed low” (Warning)**

| Situation | Solution |
|---------------------------------------|--|
| Wire unit of the fan disconnected. | Check if the wire unit of the fan is connected with the Signal backplane See reference 2 image 4-22. Check the fan connection with the wire unit to the signal backplane. See reference 1 image 4-22. |
| Blocked fan. | Unblock the fan. Ensure that the fan can turn freely. |
| Damaged wire unit. | Check if the wire unit of the fan is not damaged. Repair if possible, otherwise replace with new one. |
| Fan end of life. | Replace the fan. |
| Malfunction Fan & Motor Control Board | Replace the Fan & Motor Control Board. See "Removing a board in the card cage", page 221. |

4. Troubleshooting

| Situation | Solution |
|-----------------------------------|--|
| Other fans are also not spinning. | Replace the SMPS Board. See "Replacement of the Switched Mode Power Supply", page 289. |
| Defect Signal Backplane | Replace the Signal Backplane, see "Replacement of the signal back plane", page 239. |

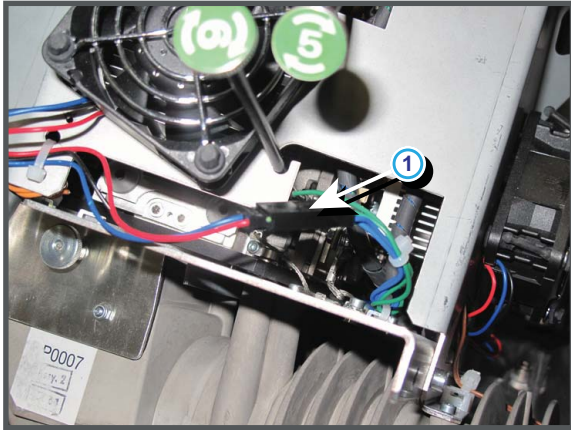
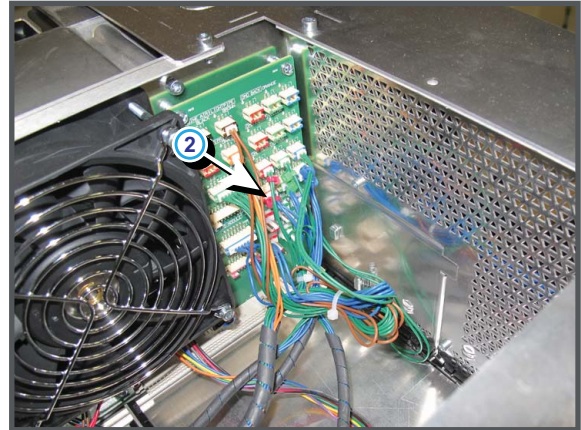

Image 4-22
Red DMD fan indication



Code 5263: “dmd green fan - speed low” (Warning)

| Situation | Solution |
|---------------------------------------|--|
| Wire unit of the fan disconnected. | Check if the wire unit of the fan is connected with the Signal backplane See reference 2 image 4-23. Check the fan connection with the wire unit to the signal backplane. |
| Blocked fan. | Unblock the fan. Ensure that the fan can turn freely. |
| Damaged wire unit. | Check if the wire unit of the fan is not damaged. Repair if possible, otherwise replace with new one. |
| Fan end of life. | Replace the fan. |
| Malfunction Fan & Motor Control Board | Replace the Fan & Motor Control Board. See "Removing a board in the card cage", page 221. |
| Other fans are also not spinning. | Replace the SMPS Board. See "Replacement of the Switched Mode Power Supply", page 289. |
| Defect Signal Backplane | Replace the Signal Backplane, see "Replacement of the signal back plane", page 239. |

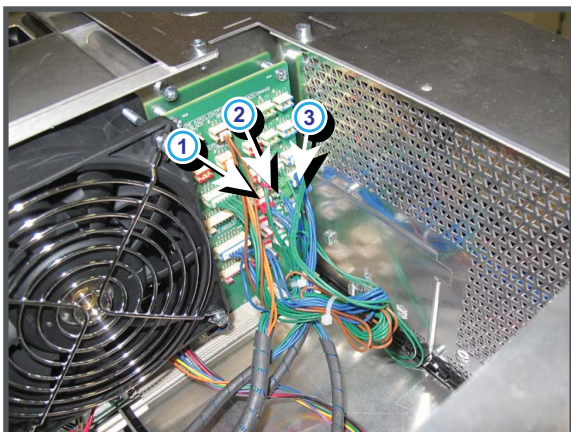

Image 4-23
Light processor fan connections

Code 5273: “dmd blue fan - speed low” (Warning)

| Situation | Solution |
|---------------------------------------|--|
| Wire unit of the fan disconnected. | Check if the wire unit of the fan is connected with the Signal backplane See reference 3 image 4-23. Check the fan connection with the wire unit to the signal backplane. |
| Blocked fan. | Unblock the fan. Ensure that the fan can turn freely. |
| Damaged wire unit. | Check if the wire unit of the fan is not damaged. Repair if possible, otherwise replace with new one. |
| Fan end of life. | Replace the fan. |
| Malfunction Fan & Motor Control Board | Replace the Fan & Motor Control Board. See "Removing a board in the card cage", page 221. |
| Other fans are also not spinning. | Replace the SMPS Board. See "Replacement of the Switched Mode Power Supply", page 289. |
| Defect Signal Backplane | Replace the Signal Backplane, see "Replacement of the signal back plane", page 239. |

Code 5280: “ambient - temperature too high” (Error)

This error code is probably preceded by the warning code: ambient - temperature high”.

| Situation | Solution |
|--|--|
| Ambient temperature too high. | Check the ambient temperature at the air inlets of the projector. Make sure that the ambient temperature does not exceed 35°C (95°F). |
| Blocked filter at the front side of the projector. | Clean the front filter or replace with new one. See "Removing the front dust filter", page 341 |
| Malfunction air extraction system. | Check the condition of the air extraction system. The air extraction system must be capable of removing minimum 6,65 m ³ /min or 235 CFM per installed digital projector. |
| Malfunction Fan Control board. | Replace the Fan Control board. See "Removing a board in the card cage", page 221. |

Code 5281: “ambient - temperature high” (Warning)

| Situation | Solution |
|---|--|
| Blocked high density filter at the front side of the projector. | Replace the front high density filter with a new one. See "Removing the front dust filter", page 341. |
| Ambient temperature too high. | Check the ambient temperature at the air inlets of the projector. Make sure that the ambient temperature does not exceed 35°C (95°F). |
| Malfunction air extraction system. | Check the condition of the air extraction system. The air extraction system must be capable of removing minimum 6,65 m ³ /min or 235 CFM per installed digital projector. |

Code 5283: “ambient - temperature low” (Warning)

| Situation | Solution |
|--|---|
| Ambient temperature is too low. | Check the ambient temperature at the air inlets of the projector. Makes sure that the ambient temperature is not lower than 0°C (32°F). |
| Defect temperature sensor. | Replace the Fan & Motor Control board. See "Removing a board in the card cage", page 221. |
| Malfunction Fan & Motor Control board. | Replace the Fan & Motor Control board. See "Removing a board in the card cage", page 221. |

Code 5284: “ambient - temperature sensor open” (Error)

| Situation | Solution |
|--------------------------------|---|
| Malfunction Fan Control board. | Replace the Fan Control board, see "Removing a board in the card cage", page 221. |

Code 5285: “ambient - temperature sensor short” (Error)

| Situation | Solution |
|--------------------------------|---|
| Malfunction Fan Control board. | Replace the Fan Control board. See "Removing a board in the card cage", page 221. |

Code 5290: “dmd blue - temperature too high” (Error)

This error code is probably preceded by the warning code 5291: “dmd blue - temperature high”. The same troubleshooting table can be applied.

Code 5291: “dmd blue - temperature high” (Error)

| Situation | Solution |
|---|---|
| Blocked fan of the blue channel. | Check if the fan can turn freely. |
| The wire unit of the temperature sensor (NTC) of the DMD in the blue channel is disconnected from the Signal backplane. | Check if the wire unit (reference 3 image 4-24) of the temperature sensor (NTC) of the DMD in the blue channel is connected with the Signal backplane. |
| Defect temperature sensor which measures the temperature at the rear side of the DMD of the blue channel. | Replace the whole Light Processor Unit. Contact Barco for further instructions to repair the malfunction Light Processor Unit. It is too critical to replace this temperature sensor in the field. The replacement of this temperature sensor must be done at factory or at an authorized service center. |

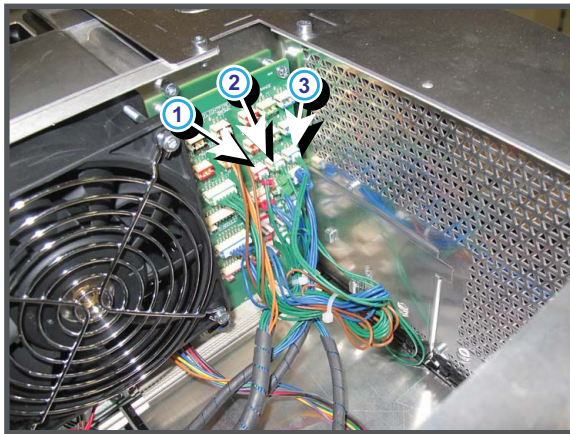

Image 4-24
DMD temperature sensor connections

Code 5293: “dmd blue - temperature low” (Warning)

| Situation | Solution |
|--|--|
| The electronics of the Light Processor Unit remains off due to a low DMD temperature. | Make sure that the ambient temperature is within specs (higher than 10°C (50°F)). Let the projector acclimate. Do not ignite the lamp, otherwise there is a risk for condensation. |
| Defect temperature sensor which measures the temperature of the DMD of the blue channel. | Replace the whole Light Processor Unit. Contact Barco for further instructions to repair the malfunction Light Processor Unit. |

Code 5294: “dmd blue - temperature sensor open” (Error)

| Situation | Solution |
|--|---|
| Wire units of the temperature sensors are disconnected from the Signal Backplane. | Check if the wire units (reference 3 image 4-24) of the temperature sensors are plugged into their sockets on the Signal Backplane. |
| Damaged wire unit of the temperature sensors (reference 3 image 4-24) which measures the temperature of the DMD of the blue channel. | <ol style="list-style-type: none"> 1. Repair the wire unit. 2. If not repairable, replace the whole Light Processor Unit. Contact Barco for further instructions to repair the malfunction Light Processor Unit. |
| Defect temperature sensor which measures the temperature of the blue channel. | Replace the whole Light Processor Unit. Contact Barco for further instructions to repair the malfunction Light Processor Unit. It is too critical to replace this temperature sensor in the field. The replacement of this temperature sensor must be done at factory or at an authorized service center. |

Code 5295: “dmd blue - temperature sensor short” (Error)

| Situation | Solution |
|--|---|
| Damaged wire unit of the temperature sensors (reference 3 image 4-24) which measures the temperature of the DMD of the blue channel. | <ol style="list-style-type: none"> 1. Repair the wire unit. 2. If not repairable, replace the whole Light Processor Unit. Contact Barco for further instructions to repair the malfunction Light Processor Unit. |
| Defect temperature sensor which measures the temperature of the blue channel. | Replace the whole Light Processor Unit. Contact Barco for further instructions to repair the malfunction Light Processor Unit. It is too critical to replace this temperature sensor in the field. The replacement of this temperature sensor must be done at factory or at an authorized service center. |

Code 5300: “dmd green - temperature too high” (Error)

This error code is probably preceded by the warning code 5301 : “dmd green - temperature high”. The same troubleshooting table can be applied.

Code 5301: “dmd green - temperature high” (Error)

| Situation | Solution |
|--|---|
| Blocked fan of the green channel. | Check if the fan can turn freely. |
| The wire unit of the temperature sensor (NTC) of the DMD in the green channel is disconnected from the Signal backplane. | Check if the wire unit (reference 2 image 4-24) of the temperature sensor (NTC) of the DMD in the green channel is connected with the Signal backplane. |
| Defect temperature sensor which measures the temperature at the rear side of the DMD of the green channel. | Replace the whole Light Processor Unit. Contact Barco for further instructions to repair the malfunction Light Processor Unit. It is too critical to replace this temperature sensor in the field. The replacement of this temperature sensor must be done at factory or at an authorized service center. |

Code 5303: “dmd green - temperature low” (Warning)

| Situation | Solution |
|---|--|
| The electronics of the Light Processor Unit remains off due to a low DMD temperature. | Make sure that the ambient temperature is within specs (higher then 10°C (50°F)). Let the projector acclimate. Do not ignite the lamp, otherwise there is a risk for condensate. |
| Defect temperature sensor which measures the temperature of the DMD of the green channel. | Replace the whole Light Processor Unit. Contact Barco for further instructions to repair the malfunction Light Processor Unit. |

Code 5304: “dmd green - temperature sensor open” (Error)

| Situation | Solution |
|---|---|
| Wire units of the temperature sensors are disconnected from the Signal Backplane. | Check if the wire units (reference 2 image 4-24) of the temperature sensors are plugged into their sockets on the Signal Backplane. |
| Damaged wire unit of the temperature sensors (reference 2 image 4-24) which measures the temperature of the DMD of the green channel. | <ol style="list-style-type: none"> 1. Repair the wire unit. 2. If not repairable, replace the whole Light Processor Unit. Contact Barco for further instructions to repair the malfunction Light Processor Unit. |
| Defect temperature sensor which measures the temperature of the green channel. | Replace the whole Light Processor Unit. Contact Barco for further instructions to repair the malfunction Light Processor Unit. It is too critical to replace this temperature sensor in the field. The replacement of this temperature sensor must be done at factory or at an authorized service center. |

4. Troubleshooting

Code 5305: “dmd green - temperature sensor short” (Error)

| Situation | Solution |
|---|---|
| Damaged wire unit of the temperature sensors (reference 2 image 4-24) which measures the temperature of the DMD of the green channel. | <ol style="list-style-type: none"> 1. Repair the wire unit. 2. If not repairable, replace the whole Light Processor Unit. Contact Barco for further instructions to repair the malfunction Light Processor Unit. |
| Defect temperature sensor which measures the temperature of the green channel. | Replace the whole Light Processor Unit. Contact Barco for further instructions to repair the malfunction Light Processor Unit. It is too critical to replace this temperature sensor in the field. The replacement of this temperature sensor must be done at factory or at an authorized service center. |

Code 5310: “lamp - temperature too high” (Error)

This error code is probably preceded by the warning code 5311 : “lamp - temperature high”. The same troubleshooting table can be applied.

Code 5311: “lamp - temperature high” (Warning)

| Situation | Solution |
|---|---|
| Ambient temperature too high. | Check the ambient temperature at the air inlets of the projector. Make sure that the ambient temperature does not exceed 35°C (95°F). |
| Blocked filters. | Check filters. Clean filthy filters or replace with new ones. |
| Malfunction air extraction system. | Check customer air extraction system for adequate extraction. The air extraction system must be capable of removing minimum 6,65 m³/min or 235 CFM per installed digital projector. |
| Malfunction lamp anode fan or lamp cathode fan. | Check the speed and voltage of the lamp anode and lamp cathode fan. Replace any malfunction fan. |

Code 5314: “lamp - temperature sensor open” (Error)

| Situation | Solution |
|--|---|
| Wire unit (reference 3 image 4-25) of the temperature sensor is disconnected from the Signal Backplane. | Plug the wire unit of the temperature sensor into its socket on the Signal Backplane. |
| Disconnected wire (reference 2 image 4-25) units between Signal Backplane and temperature sensor in the air outlet channel of the projector. | Check the connection between the wire units. The connection is made behind the back cover. |
| Damaged wire unit of the temperature sensor (reference 1 image 4-25). | <ol style="list-style-type: none"> 1. Repair the wire unit. 2. If not repairable, replace the whole wire unit and temperature sensor. |
| Defect temperature sensor (reference 1 image 4-25). | Replace the temperature sensor. Temperature sensor is visible through the air outlet on top of the projector. |
| | |

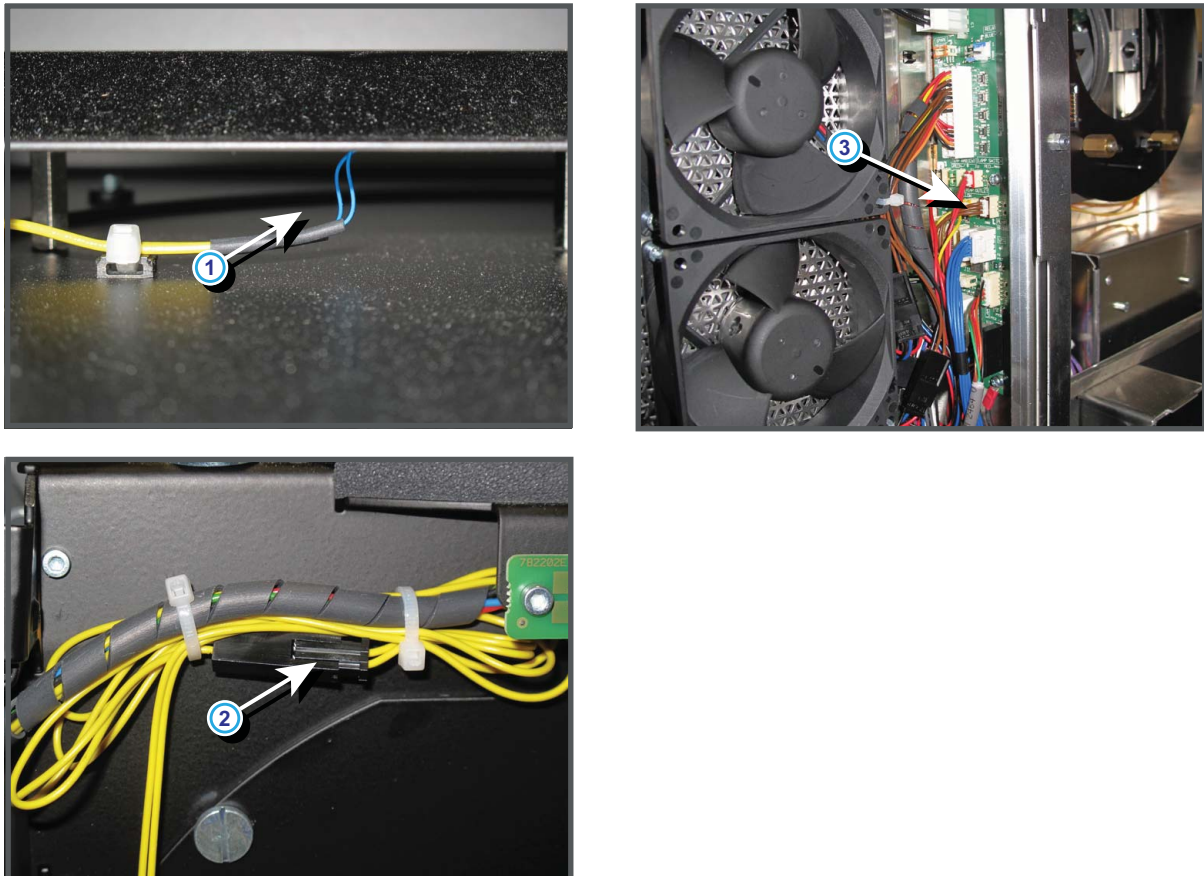

Image 4-25
Lamp temperature sensor connection

Code 5315: "lamp - temperature sensor short " (Error)

| Situation | Solution |
|---|---|
| Damaged insulation of the wire unit of the temperature sensor (reference 1 & 2 image 4-25), which measures the temperature in the channel of the air outlet of the Lamp House. When disconnecting the wire unit of the temperature sensor from the Signal Backplane (reference 3 image 4-25) the error code is changed to "lamp - temperature sensor open". | <ol style="list-style-type: none"> 1. Repair the insulation of the wire unit using shrink sleeve. 2. If not repairable, replace the whole wire unit and temperature sensor. |
| Defect temperature sensor (reference 1 image 4-25), which measures the temperature in the channel of the air outlet of the Lamp House. When disconnecting the wire unit of the temperature sensor from the Signal Backplane (reference 3 image 4-25) the error code is changed to "lamp - temperature sensor open". | Replace the temperature sensor. |

Code 5320: "fcb - force lps/lamp off " (Error)

| Situation | Solution |
|---|---|
| The Fan Control & Motor board forces to switch off the Lamp Power Supply due to an Error. | <p>Look for other errors in the log files and try to solve them.</p> <p>This can be due to:</p> <ul style="list-style-type: none"> • Overtemperature • Lamp house not connected. • Light processor is not connected. |
| Malfunction Fan Control & Motor board. | Replace the Fan Control & Motor board. See "Removing a board in the card cage", page 221. |

Code 5331: “pfc heatsink - temperature high” (Warning)

| Situation | Solution |
|--------------------------------|---|
| Ambient temperature too high. | Check the ambient temperature at the air inlets of the projector. Make sure that the ambient temperature does not exceed 35°C (95°F). |
| Blocked front filter. | Clean the filter at the front side of the projector or replace with a new one. See "Removing the front dust filter", page 341. |
| Malfunction SMPS module | Replace the SMPS module, see "Replacement of the Switched Mode Power Supply", page 289. |
| Malfunction Fan Control board. | Replace the Fan Control board. See "Removing a board in the card cage", page 221. |

Code 5340: “dmd red - temperature too high” (Error)

This error code is probably preceded by the warning code 5341 : “dmd red - temperature high”. The same troubleshooting table can be applied.

Code 5341: “dmd red - temperature high” (Error)

| Situation | Solution |
|--|---|
| Blocked fan of the red channel. | Check if the fan can turn freely. |
| The wire unit of the temperature sensor (NTC) of the DMD in the red channel is disconnected from the Signal backplane. | Check if the wire unit (reference 1 image 4-24) of the temperature sensor (NTC) of the DMD in the red channel is connected with the Signal backplane. |
| Defect temperature sensor which measures the temperature at the rear side of the DMD of the red channel. | Replace the whole Light Processor Unit. Contact Barco for further instructions to repair the malfunction Light Processor Unit. It is too critical to replace this temperature sensor in the field. The replacement of this temperature sensor must be done at factory or at an authorized service center. |

Code 5343: “dmd red - temperature low” (Warning)

| Situation | Solution |
|---|--|
| The electronics of the Light Processor Unit remains off due to a low DMD temperature. | Make sure that the ambient temperature is within specs (higher then 10°C (50°F)). Let the projector acclimate. Do not ignite the lamp, otherwise there is a risk for condensation. |
| Defect temperature sensor which measures the temperature of the DMD of the red channel. | Replace the whole Light Processor Unit. Contact Barco for further instructions to repair the malfunction Light Processor Unit. |

Code 5344: “dmd red - temperature sensor open” (Error)

| Situation | Solution |
|--|---|
| Wire units of the temperature sensors are disconnected from the Signal Backplane. | Check if the wire units (reference 1 image 4-24) of the temperature sensors are plugged into their sockets on the Signal Backplane. |
| Damaged wire unit of the temperature sensors (reference 1image 4-24) which measures the temperature of the DMD of the red channel. | <ol style="list-style-type: none"> 1. Repair the wire unit. 2. If not repairable, replace the whole Light Processor Unit. Contact Barco for further instructions to repair the malfunction Light Processor Unit. |
| Defect temperature sensor which measures the temperature of the red channel. | Replace the whole Light Processor Unit. Contact Barco for further instructions to repair the malfunction Light Processor Unit. It is too critical to replace this temperature sensor in the field. The replacement of this temperature sensor must be done at factory or at an authorized service center. |

Code 5345: “dmd red - temperature sensor short” (Error)

| Situation | Solution |
|---|---|
| Damaged wire unit of the temperature sensors (reference 1 image 4-24) which measures the temperature of the DMD of the red channel. | <ol style="list-style-type: none"> 1. Repair the wire unit. 2. If not repairable, replace the whole Light Processor Unit. Contact Barco for further instructions to repair the malfunction Light Processor Unit. |
| Defect temperature sensor which measures the temperature of the red channel. | Replace the whole Light Processor Unit. Contact Barco for further instructions to repair the malfunction Light Processor Unit. It is too critical to replace this temperature sensor in the field. The replacement of this temperature sensor must be done at factory or at an authorized service center. |

Code 5351: “smps primary heatsink - temperature high” (Warning)

| Situation | Solution |
|--------------------------------|---|
| Ambient temperature too high. | Check the ambient temperature at the air inlets of the projector. Make sure that the ambient temperature does not exceed 35°C (95°F). |
| Blocked front filter. | Clean the filter at the front side of the projector or replace with a new one. See "Removing the front dust filter", page 341. |
| Malfunction SMPS module | Replace the SMPS module. |
| Malfunction Fan Control board. | Replace the Fan Control board. See "Removing a board in the card cage", page 221. |

Code 5361: “smps secondary heatsink - temperature high” (Warning)

| Situation | Solution |
|--------------------------------|---|
| Ambient temperature too high. | Check the ambient temperature at the air inlets of the projector. Make sure that the ambient temperature does not exceed 35°C (95°F). |
| Blocked front filter. | Clean the filter at the front side of the projector or replace with a new one. See "Removing the front dust filter", page 341. |
| Malfunction SMPS module | Replace the SMPS module. |
| Malfunction Fan Control board. | Replace the Fan Control board. See "Removing a board in the card cage", page 221. |

Code 5364: “smps secondary heatsink - temperature sensor open ” (Error)

| Situation | Solution |
|-------------------------|---|
| Malfunction SMPS module | Replace the SMPS module. See "Replacement of the Switched Mode Power Supply", page 289. |

Code 5365: “smps secondary heatsink - temperature sensor short” (Error)

| Situation | Solution |
|-------------------------|---|
| Malfunction SMPS module | Replace the SMPS module. See "Replacement of the Switched Mode Power Supply", page 289. |

Code 5371: “dmd red fan - voltage high” (Warning)

| Situation | Solution |
|--|--|
| Malfunction Fan & Motor Control board. | Replace the Fan & Motor Control board. See "Removing a board in the card cage", page 221 |

Code 5372: “dmd red fan - voltage too low” (Error)

| Situation | Solution |
|--|---|
| Malfunction SMPS module. All other fans also report voltage low error. | Replace the SMPS module. See "Replacement of the Switched Mode Power Supply", page 289 |
| Damaged insulation of the wire unit of the DMD red fan. | <p>Remove the Light Processor from the projector and check the insulation of the wire unit of the fan.</p> <ol style="list-style-type: none"> 1. Repair the insulation of the wire unit using shrink sleeve. 2. If not repairable, replace the whole wire unit and fan. |
| Malfunction Fan & Motor Control board. | Replace the Fan & Motor Control board. See "Removing a board in the card cage", page 221 |
| Malfunction signal backplane | Replace the signal backplane, see "Replacement of the signal back plane", page 239. |

Code 5373: “dmd red fan - voltage low” (Warning)

| Situation | Solution |
|--|---|
| Malfunction SMPS module. All other fans also report voltage low error. | Replace the SMPS module. See "Replacement of the Switched Mode Power Supply", page 289 |
| Damaged insulation of the wire unit of the DMD red fan. | Remove the Light Processor from the projector and check the insulation of the wire unit of the fan. 1. Repair the insulation of the wire unit using shrink sleeve. 2. If not repairable, replace the whole wire unit and fan. |
| Malfunction Fan & Motor Control board. | Replace the Fan & Motor Control board. See "Removing a board in the card cage", page 221 |
| Malfunction signal backplane | Replace the signal backplane, see "Replacement of the signal back plane", page 239. |

Code 5381: “dmd green fan - voltage high” (Warning)

| Situation | Solution |
|--|--|
| Malfunction Fan & Motor Control board. | Replace the Fan & Motor Control board. See "Removing a board in the card cage", page 221 |

Code 5382: “dmd green fan - voltage too low” (Error)

| Situation | Solution |
|--|---|
| Malfunction SMPS module. All other fans also report voltage low error. | Replace the SMPS module. See "Replacement of the Switched Mode Power Supply", page 289 |
| Damaged insulation of the wire unit of the DMD green fan. | Remove the Light Processor from the projector and check the insulation of the wire unit of the fan. 1. Repair the insulation of the wire unit using shrink sleeve. 2. If not repairable, replace the whole wire unit and fan. |
| Malfunction Fan & Motor Control board. | Replace the Fan & Motor Control board. See "Removing a board in the card cage", page 221 |
| Malfunction signal backplane | Replace the signal backplane, see "Replacement of the signal back plane", page 239. |

Code 5383: “dmd green fan - voltage low” (Warning)

| Situation | Solution |
|--|---|
| Malfunction SMPS module. All other fans also report voltage low error. | Replace the SMPS module. See "Replacement of the Switched Mode Power Supply", page 289 |
| Damaged insulation of the wire unit of the DMD green fan. | Remove the Light Processor from the projector and check the insulation of the wire unit of the fan. 1. Repair the insulation of the wire unit using shrink sleeve. 2. If not repairable, replace the whole wire unit and fan. |
| Malfunction Fan & Motor Control board. | Replace the Fan & Motor Control board. See "Removing a board in the card cage", page 221 |
| Malfunction signal backplane | Replace the signal backplane, see "Replacement of the signal back plane", page 239. |

Code 5391: “dmd blue fan - voltage high” (Warning)

| Situation | Solution |
|--|--|
| Malfunction Fan & Motor Control board. | Replace the Fan & Motor Control board. See "Removing a board in the card cage", page 221 |

Code 5392: “dmd blue fan - voltage low” (Error)

| Situation | Solution |
|--|---|
| Malfunction SMPS module. All other fans also report voltage low error. | Replace the SMPS module. See "Replacement of the Switched Mode Power Supply", page 289 |
| Damaged insulation of the wire unit of the DMD blue fan. | Remove the Light Processor from the projector and check the insulation of the wire unit of the fan. 1. Repair the insulation of the wire unit using shrink sleeve. 2. If not repairable, replace the whole wire unit and fan. |

| Situation | Solution |
|--|--|
| Malfunction Fan & Motor Control board. | Replace the Fan & Motor Control board. See "Removing a board in the card cage", page 221 |
| Malfunction signal backplane | Replace the signal backplane, see "Replacement of the signal back plane", page 239. |

Code 5393: "dmd blue fan - voltage low" (Warning)

| Situation | Solution |
|--|---|
| Malfunction SMPS module. All other fans also report voltage low error. | Replace the SMPS module. See "Replacement of the Switched Mode Power Supply", page 289 |
| Damaged insulation of the wire unit of the DMD blue fan. | Remove the Light Processor from the projector and check the insulation of the wire unit of the fan. <ol style="list-style-type: none"> 1. Repair the insulation of the wire unit using shrink sleeve. 2. If not repairable, replace the whole wire unit and fan. |
| Malfunction Fan & Motor Control board. | Replace the Fan & Motor Control board. See "Removing a board in the card cage", page 221 |
| Malfunction signal backplane | Replace the signal backplane, see "Replacement of the signal back plane", page 239. |

Code 5431: "cold mirror fan - voltage high" (Warning)

| Situation | Solution |
|--|--|
| Malfunction Fan Control board or SMPS board. | Measure on the Signal Backplane the +24V voltage on pin 9, 10, 11 or 12 of the connector of the black wire unit which comes from the SMPS board. See image 4-26. If the measured voltage is about 24V then replace the Fan Control board. See "Removing a board in the card cage", page 221. Otherwise replace the SMPS board. See "Replacement of the Switched Mode Power Supply", page 289. |

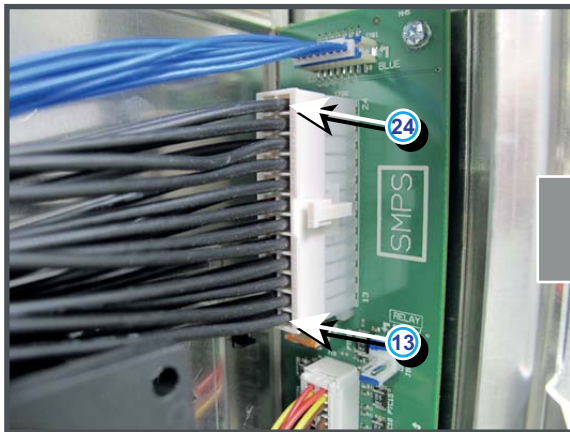
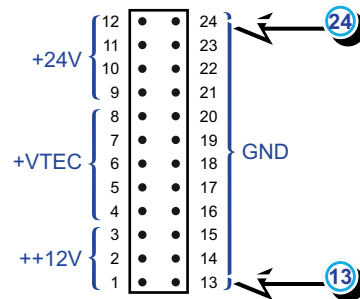

Image 4-26

**Code 5432: "cold mirror fan - voltage too low" (Error)**

This error code is probably preceded by the warning code 5433 : "cold mirror fan - voltage low". The same troubleshooting table can be applied.

Code 5433: "cold mirror fan - voltage low" (Warning)

| Situation | Solution |
|--|---|
| Malfunction Fan Control board or SMPS board. | Measure on the Signal Backplane the +24V voltage on pin 9, 10, 11 or 12 of the connector of the black wire unit which comes from the SMPS board. See image 4-26. If the measured voltage is about 24V then replace the Fan Control board. See "Removing a board in the card cage", page 221. Otherwise replace the SMPS board. See "Replacement of the Switched Mode Power Supply", page 289. |
| Short circuit or bad connection. | <ol style="list-style-type: none"> 1. Check the Signal Backplane for bad connections. Ensure that all wire units are well connected. (Note that the +24V supply is generated on the SMPS board and enters the Fan Control board and Cinema Control board via the Signal Backplane) 2. Check the wiring of the Anode fan for short circuits. 3. Check the wiring of the Cathode fan for short circuits. |

4. Troubleshooting

| Situation | Solution |
|---|--|
| Damaged insulation of the brown/red wire unit (reference 2 image 4-27) of the cold mirror fan (reference 1 image 4-27). | Remove the top cover of the projector, pull out the top dust filter to access the fan connection. Check the insulation of the wire unit. <ol style="list-style-type: none"> 1. Repair the insulation of the wire unit using shrink sleeve. 2. If the wire unit of the fan is not repairable, replace the Cold Mirror fan. See "Removal of the cold mirror assembly", page 125. |
| Malfunction Signal Backplane (bad connection) | Replace the Signal Backplane. See "Replacement of the signal back plane", page 239. |

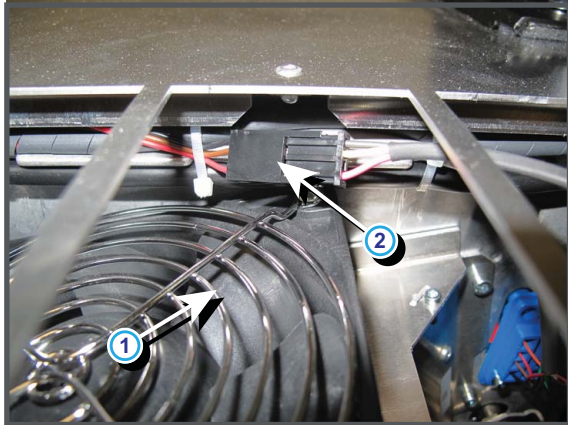

Image 4-27
Cold mirror fan connection

Code 5441: "engine fan - voltage high" (Warning)

| Situation | Solution |
|--|--|
| Malfunction Fan Control board or SMPS board. | Measure on the Signal Backplane the +24V voltage on pin 9, 10, 11 or 12 of the connector of the black wire unit which comes from the SMPS board. See image 4-26. If the measured voltage is about 24V then replace the Fan Control board. See "Removing a board in the card cage", page 221. Otherwise replace the SMPS board. See "Replacement of the Switched Mode Power Supply", page 289. |

Code 5442: "engine fan - voltage too low" (Error)

This error code is probably preceded by the warning code 5443: "engine fan - voltage low". The same troubleshooting table can be applied.

Code 5443: "engine fan - voltage low" (Warning)

| Situation | Solution |
|---|---|
| Malfunction Fan Control board or SMPS board. | Measure on the Signal Backplane the +24V voltage on pin 9, 10, 11 or 12 of the connector of the black wire unit which comes from the SMPS board. See image 4-26. If the measured voltage is about 24V then replace the Fan Control board. See "Removing a board in the card cage", page 221. Otherwise replace the SMPS board. See "Replacement of the Switched Mode Power Supply", page 289. |
| Short circuit or bad connection. | <ol style="list-style-type: none"> 1. Check the Signal Backplane for bad connections. Ensure that all wire units are well connected. (Note that the +24V supply is generated on the SMPS board and enters the Fan Control board and Cinema Control board via the Signal Backplane) 2. Check the wiring of the Anode fan for short circuits. 3. Check the wiring of the Cathode fan for short circuits. |
| Damaged insulation of the wire unit (reference 21 image 4-28) of the Light Processor fan (reference 1 image 4-28). Note that this fan is located between the Card Cage compartment and Light Processor compartment. | Check the insulation of the wire unit of the fan. The fan is accessible via the Card Cage. <ol style="list-style-type: none"> 1. Repair the insulation of the wire unit using shrink sleeve. 2. If not repairable, replace the whole wire unit and/or fan. See "Light processor compartment fan", page 324. |
| Malfunction Signal Backplane (bad connection) | Replace the Signal Backplane. See "Replacement of the signal back plane", page 239 |

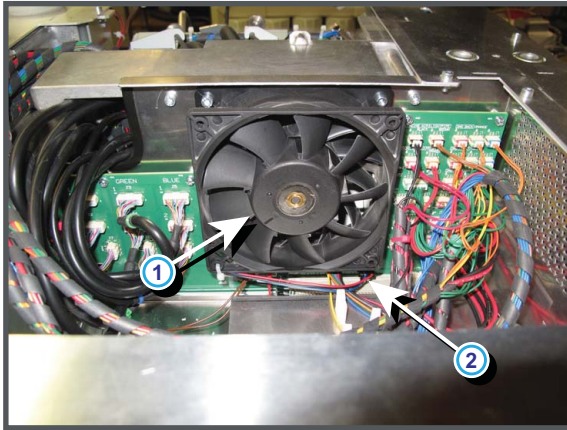

Image 4-28
Light processor fan

Code 5461: “lamp anode fan - voltage high” (Warning)

| Situation | Solution |
|--|--|
| Malfunction Fan Control board or SMPS board. | Measure on the Signal Backplane the +24V voltage on pin 9, 10, 11 or 12 of the connector of the black wire unit which comes from the SMPS board. See image 4-26. If the measured voltage is about 24V then replace the Fan Control board. See "Removing a board in the card cage", page 221. Otherwise replace the SMPS board. See "Replacement of the Switched Mode Power Supply", page 289. |

Code 5462: “lamp anode fan - voltage too low” (Error)

This error code is probably preceded by the warning code 5463: “lamp anode fan - voltage low”. The same troubleshooting table can be applied.

Code 5463: “lamp anode fan - voltage low” (Warning)

| Situation | Solution |
|---|---|
| Malfunction SMPS module. All other fans also report voltage low error. | Replace the SMPS module. See "Replacement of the Switched Mode Power Supply", page 289. |
| Damaged insulation of the wire unit (reference 2 image 4-29) of the Anode fan (reference 1 image 4-29). | Check the insulation of the wire unit of the Anode fan. The Anode fan is located below the compartment of the Light Processor. 1. Repair the insulation of the wire unit using shrink sleeve. 2. If not repairable replace the Anode fan. See "Lamp anode fan", page 332. |
| Malfunction Fan & Motor Control board. | Replace the Fan & Motor Control board. See "Removing a board in the card cage", page 221 |
| Malfunction Signal Backplane (bad connection) | Replace the Signal Backplane. See "Replacement of the signal back plane", page 239. |

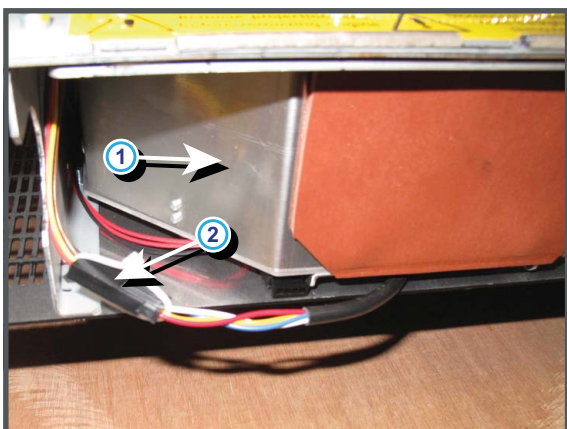

Image 4-29
Anode fan connection

Code 5471: “lamp cathode fan - voltage high” (Warning)

| Situation | Solution |
|--|--|
| Malfunction Fan Control board or SMPS board. | Measure on the Signal Backplane the +24V voltage on pin 9, 10, 11 or 12 of the connector of the black wire unit which comes from the SMPS board. See image 4-26. If the measured voltage is about 24V then replace the Fan Control board. See "Removing a board in the card cage", page 221. Otherwise replace the SMPS board. See "Replacement of the Switched Mode Power Supply", page 289. |

Code 5472: “lamp cathode fan - voltage too low” (Error)

This error code is probably proceeded by the warning code 5473: “lamp cathode fan - voltage low”. The same troubleshooting table can be applied.

Code 5473: “lamp cathode fan - voltage low” (Warning)

| Situation | Solution |
|---|--|
| Malfunction Fan Control board or SMPS board. | Measure on the Signal Backplane the +24V voltage on pin 9, 10, 11 or 12 of the connector of the black wire unit which comes from the SMPS board. See image 4-26. If the measured voltage is about 24V then replace the Fan Control board. See "Removing a board in the card cage", page 221. Otherwise replace the SMPS board. See "Replacement of the Switched Mode Power Supply", page 289. |
| Damaged insulation of the wire unit (reference 1 image 4-30) of the Cathode fan (reference 3 image 4-30). | To Check the insulation of the wire unit of the Cathode fan, pull out the wire unit (reference 1 image 4-30). The Cathode fan is located at the right inner side of the Lamp compartment. 1. Repair the insulation of the wire unit using shrink sleeve. 2. If not repairable replace the Cathode fan. See "Lamp cathode fan", page 327. |
| Malfunction Signal Backplane (bad connection) | Replace the Signal Backplane. See "Replacement of the signal back plane", page 239. |

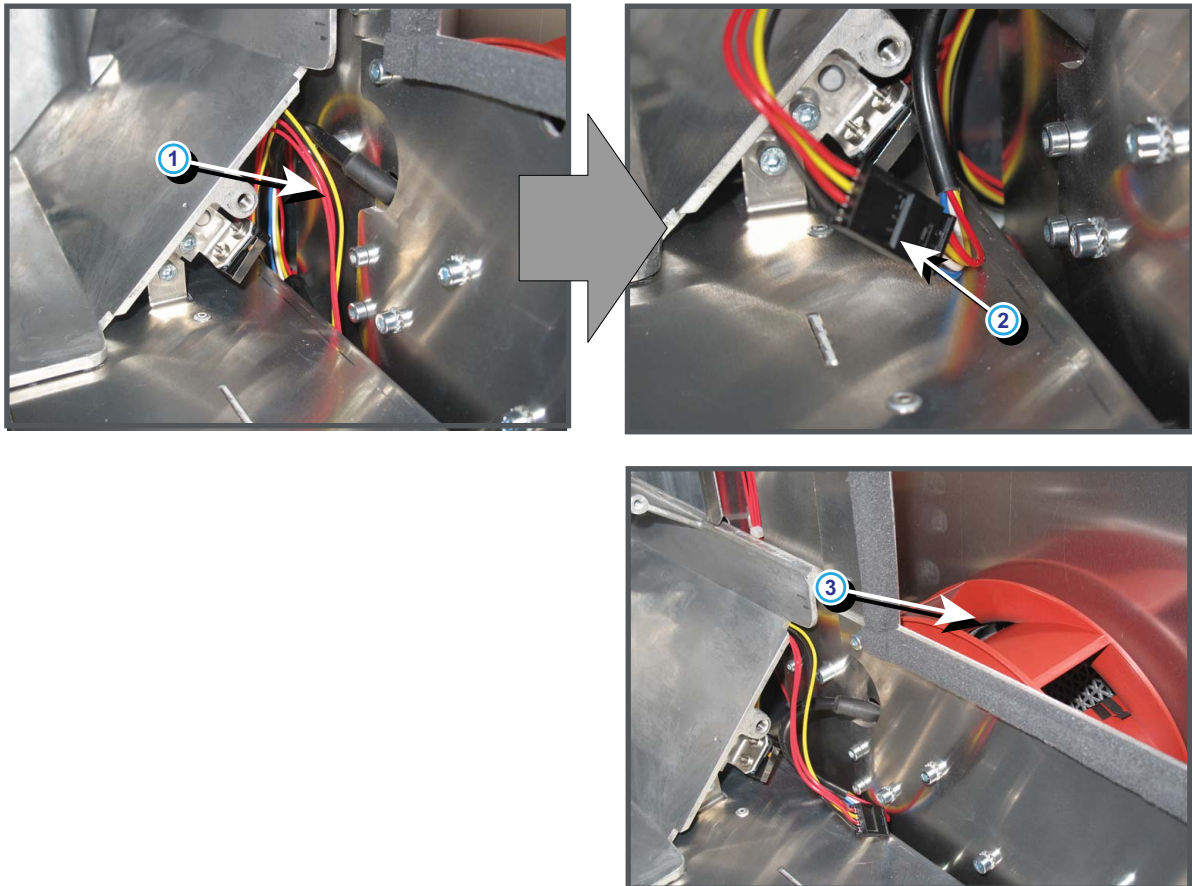

Image 4-30
Cathode fan connections

Code 5491: “smps fan - voltage high” (Warning)

| Situation | Solution |
|--|--|
| Malfunction Fan Control board or SMPS board. | Measure on the Signal Backplane the +24V voltage on pin 9, 10, 11 or 12 of the connector of the black wire unit which comes from the SMPS board. See image 4-26. If the measured voltage is about 24V then replace the Fan Control board. See "Removing a board in the card cage", page 221. Otherwise replace the SMPS board. See "Replacement of the Switched Mode Power Supply", page 289. |

Code 5492: “smps fan - voltage too low” (Error)

This error code is probably preceded by the warning code 5493: “smps fan - voltage low”. The same troubleshooting table can be applied.

Code 5493: “smps fan - voltage low” (Warning)

| Situation | Solution |
|---|---|
| Malfunction Fan Control board or SMPS board. | Measure on the Signal Backplane the +24V voltage on pin 9, 10, 11 or 12 of the connector of the black wire unit which comes from the SMPS board. See image 4-26. If the measured voltage is about 24V then replace the Fan Control board. See "Removing a board in the card cage", page 221. Otherwise replace the SMPS board. See "Replacement of the Switched Mode Power Supply", page 289. |
| Short circuit or bad connection. | <ol style="list-style-type: none"> 1. Check the Signal Backplane for bad connections. Ensure that all wire units are well connected. (Note that the +24V supply is generated on the SMPS board and enters the Fan Control board and Cinema Control board via the Signal Backplane) 2. Check the wiring of the Anode fan for short circuits. 3. Check the wiring of the Cathode fan for short circuits. |
| Damaged insulation of the wire unit (reference 3 & 4 image 4-31) of the SMPS fans (reference 1 & 2 image 4-31). | Check the insulation of the wire unit of the SMPS fans. The two SMPS fans are located behind the front filter (two lower fans). <ol style="list-style-type: none"> 1. Repair the insulation of the wire unit using shrink sleeve. 2. If not repairable replace the Cathode fan. See "Lamp cathode fan", page 327. |
| Malfunction Signal Backplane (bad connection) | Replace the Signal Backplane. See "Replacement of the signal back plane", page 239. |

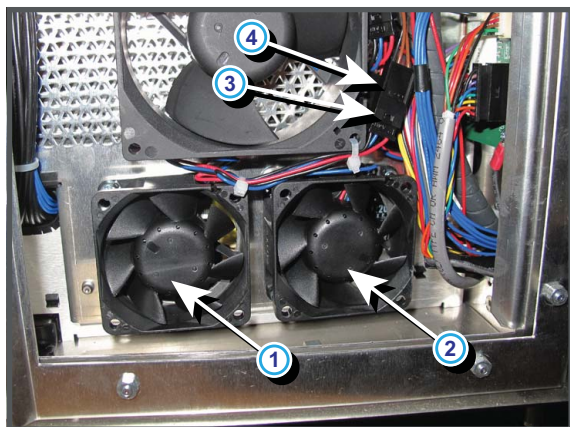

Image 4-31
SMPS fans connection

Code 5571: “lamp rear fan - voltage high” (Warning)

| Situation | Solution |
|--|--|
| Malfunction Fan Control board or SMPS board. | Measure on the Signal Backplane the +24V voltage on pin 9, 10, 11 or 12 of the connector of the black wire unit which comes from the SMPS board. See image 4-26. If the measured voltage is about 24V then replace the Fan Control board. See "Removing a board in the card cage", page 221. Otherwise replace the SMPS board. See "Replacement of the Switched Mode Power Supply", page 289. |

Code 5572: “lamp rear fan - voltage too low” (Error)

This error code is probably preceded by the warning code 5573: “lamp rear fan - voltage low”. The same troubleshooting table can be applied.

Code 5573: “lamp rear fan - voltage low” (Warning)

| Situation | Solution |
|---|---|
| Malfunction Fan Control board or SMPS board. | Measure on the Signal Backplane the +24V voltage on pin 9, 10, 11 or 12 of the connector of the black wire unit which comes from the SMPS board. See image 4-26. If the measured voltage is about 24V then replace the Fan Control board. See "Removing a board in the card cage", page 221. Otherwise replace the SMPS board. See "Replacement of the Switched Mode Power Supply", page 289. |
| Short circuit or bad connection. | <ol style="list-style-type: none"> 1. Check the Signal Backplane for bad connections. Ensure that all wire units are well connected. (Note that the +24V supply is generated on the SMPS board and enters the Fan Control board and Cinema Control board via the Signal Backplane) 2. Check the wiring of the Anode fan for short circuits. 3. Check the wiring of the Cathode fan for short circuits. |
| Damaged insulation of the wire unit (reference 2 image 4-32) of the fan (reference 1 image 4-32). | Check the insulation of the wire unit of the fan. <ol style="list-style-type: none"> 1. Repair the insulation of the wire unit using shrink sleeve. 2. If not repairable, replace the whole wire unit and/or fan. See "Lamp Info Module fan", page 337. |
| Malfunction Signal Backplane (bad connection, reference 3 image 4-32) | Replace the Signal Backplane. See "Replacement of the signal back plane", page 239. |

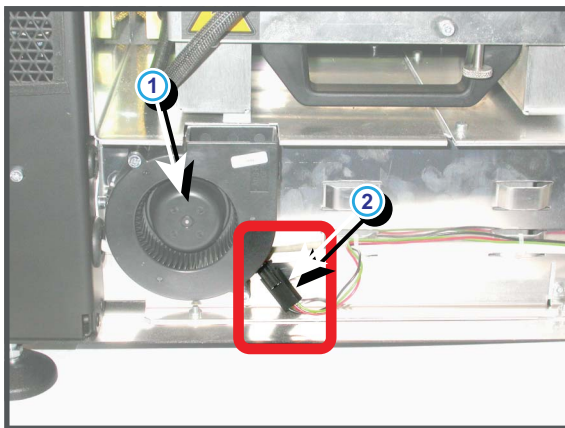
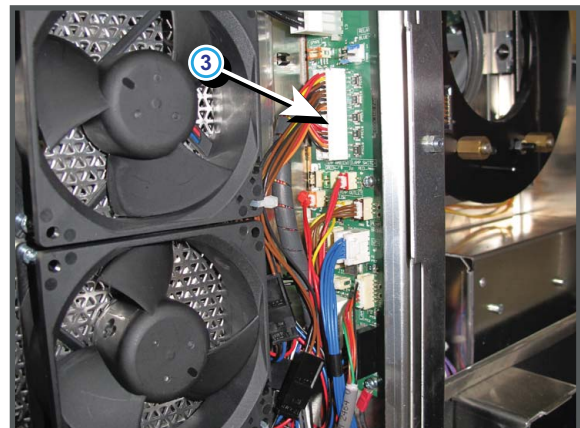

Image 4-32
Lamp rear fan connections



Code 5621: “electronics fan 1 (top side) - voltage high” (Warning)

| Situation | Solution |
|--|--|
| Malfunction Fan Control board or SMPS board. | Measure on the Signal Backplane the +24V voltage on pin 9, 10, 11 or 12 of the connector of the black wire unit which comes from the SMPS board. See image 4-26. If the measured voltage is about 24V then replace the Fan Control board. See "Removing a board in the card cage", page 221. Otherwise replace the SMPS board. See "Replacement of the Switched Mode Power Supply", page 289. |

Code 5622: “electronics fan 1 (top side) - voltage too low” (Error)

This error code is probably preceded by the warning code 5623: “electronics fan 1 (top side) - voltage low”. The same troubleshooting table can be applied.

Code 5623: “electronics fan 1 (top side) - voltage low” (Warning)

| Situation | Solution |
|--|--|
| Malfunction Fan Control board or SMPS board. | Measure on the Signal Backplane the +24V voltage on pin 9, 10, 11 or 12 of the connector of the black wire unit which comes from the SMPS board. See image 4-26. If the measured voltage is about 24V then replace the Fan Control board. See "Removing a board in the card cage", page 221. Otherwise replace the SMPS board. See "Replacement of the Switched Mode Power Supply", page 289. |

| Situation | Solution |
|--|---|
| Short circuit or bad connection. | <ol style="list-style-type: none"> 1. Check the Signal Backplane for bad connections. Ensure that all wire units are well connected. (Note that the +24V supply is generated on the SMPS board and enters the Fan Control board and Cinema Control board via the Signal Backplane) 2. Check the wiring of the Anode fan for short circuits. 3. Check the wiring of the Cathode fan for short circuits. |
| Damaged insulation of the wire unit (reference 2 image 4-33) of the upper fan (reference 1 image 4-33) for the Card Cage electronics. The fan is the upper fan located behind the dust filter at the front of the projector. | <p>Remove the dust filter at the front side of the projector and check the insulation of the wire unit of the fan.</p> <ol style="list-style-type: none"> 1. Repair the insulation of the wire unit using shrink sleeve. 2. If not repairable, replace the whole wire unit and/or fan. See "Card cage fans", page 320. |
| Malfunction Signal Backplane (bad connection) | Replace the Signal Backplane. See "Replacement of the signal back plane", page 239. |

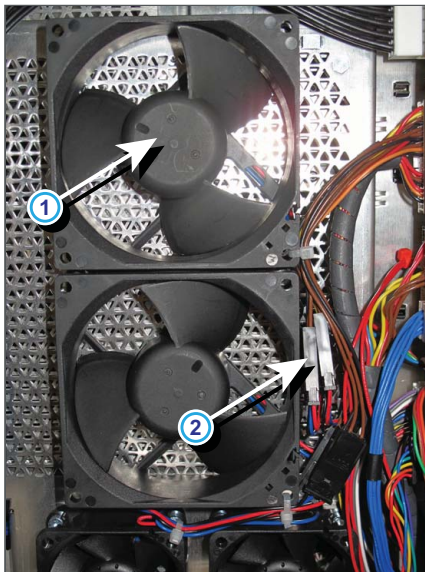

Image 4-33
Card cage, upper fan connection

Code 5631: “electronics fan 2 (bottom side) - voltage high” (Warning)

| Situation | Solution |
|--|---|
| Malfunction Fan Control board or SMPS board. | <p>Measure on the Signal Backplane the +24V voltage on pin 9, 10, 11 or 12 of the connector of the black wire unit which comes from the SMPS board. See image 4-26.</p> <p>If the measured voltage is about 24V then replace the Fan Control board. See "Removing a board in the card cage", page 221. Otherwise replace the SMPS board. See "Replacement of the Switched Mode Power Supply", page 289.</p> |

Code 5632: “electronics fan 2 (bottom side) - voltage too low” (Error)

This error code is probably preceded by the warning code 5633: “electronics fan 2 (bottom side) - voltage low”. The same troubleshooting table can be applied.

Code 5633: “electronics fan 2 (bottom side) - voltage low” (Warning)

| Situation | Solution |
|--|---|
| Malfunction Fan Control board or SMPS board. | <p>Measure on the Signal Backplane the +24V voltage on pin 9, 10, 11 or 12 of the connector of the black wire unit which comes from the SMPS board. See image 4-26.</p> <p>If the measured voltage is about 24V then replace the Fan Control board. See "Removing a board in the card cage", page 221. Otherwise replace the SMPS board. See "Replacement of the Switched Mode Power Supply", page 289.</p> |

4. Troubleshooting

| Situation | Solution |
|--|---|
| Short circuit or bad connection. | <ol style="list-style-type: none"> 1. Check the Signal Backplane for bad connections. Ensure that all wire units are well connected. (Note that the +24V supply is generated on the SMPS board and enters the Fan Control board and Cinema Control board via the Signal Backplane) 2. Check the wiring of the Anode fan for short circuits. 3. Check the wiring of the Cathode fan for short circuits. |
| Damaged insulation of the wire unit (reference 2 image 4-34) of the lower fan (reference 1 image 4-34) for the Card Cage electronics. The fan is the lower fan located behind the dust filter at the front of the projector. | <p>Remove the dust filter at the front side of the projector and check the insulation of the wire unit of the fan.</p> <ol style="list-style-type: none"> 1. Repair the insulation of the wire unit using shrink sleeve. 2. If not repairable, replace the whole wire unit and/or fan. See "Card cage fans", page 320. |
| Malfunction Signal Backplane (bad connection) | Replace the Signal Backplane. See "Replacement of the signal back plane", page 239. |

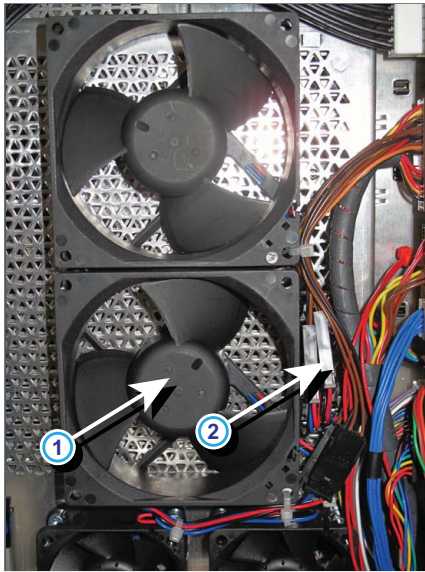

Image 4-34
Card cage, lower fan connection

Code 5640: "lamp power supplies - zero lamp power supplies detected" (Error)

| Situation | Solution |
|--|---|
| Main power cable disconnected from the LPS unit (reference 1 image 4-35). | Check if the main power cable is connected with the "MAINS INPUT" socket of the LPS unit. |
| Disconnected wire unit between the Signal Backplane and the LPS module (reference 2, LPS side and reference 3 Signal backplane side image 4-35). | Reconnect the wire unit between the Signal Backplane and the LPS module. |
| Malfunction of one of the LPS units. The red LED "ERR" of the malfunction LPS unit flashes fast. | Replace the whole LPS module. See "Lamp power supply", page 291 or "Lamp power supply (single module)", page 299. |
| Defect Signal Backplane. | Replace the Signal Backplane. See "Replacement of the signal back plane", page 239. |

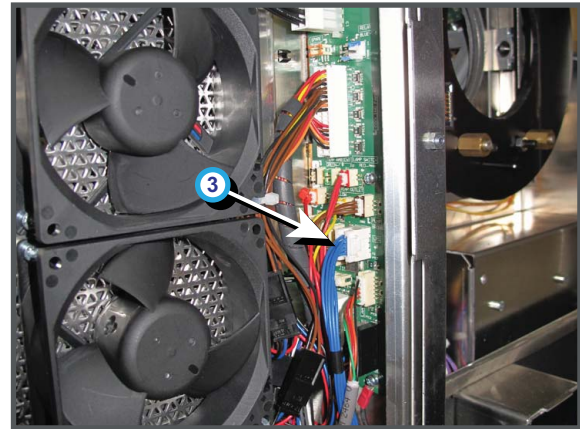
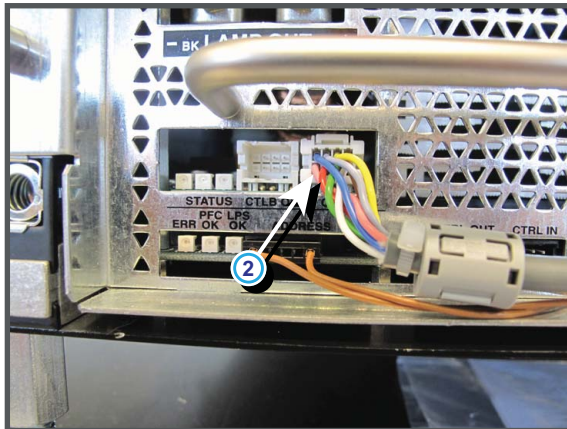
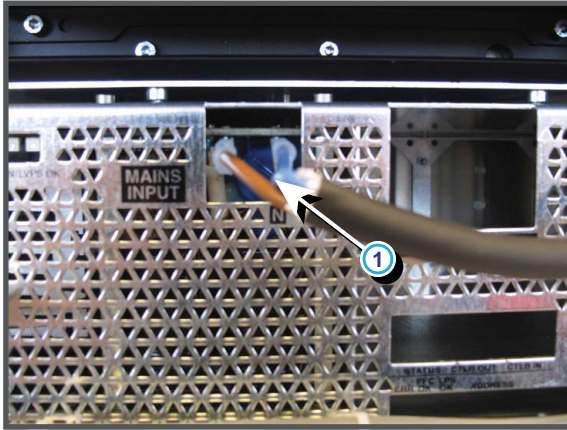

Image 4-35
Mains and CTLB connection LPS

Code 5641: “lamp power supplies - lamp is on, but smps is off” (Error)

| Situation | Solution |
|--------------------------|---|
| Malfunction SMPS module. | Replace the SMPS module. See "Replacement of the Switched Mode Power Supply", page 289. |
| Malfunction LPS module. | Replace the LPS module. See "Lamp power supply", page 291 or "Lamp power supply (single module)", page 299. |
| Defect Signal Backplane. | Replace the Signal Backplane. See "Replacement of the signal back plane", page 239. |

Code 5642: “lamp power supplies - at least one lamp power supply could not be detected” (Error)

| Situation | Solution |
|--|---|
| Main power cable disconnected from one of the LPS units (reference 1image 4-35). | Check if the main power cable is connected with the “MAINS INPUT” socket of the LPS unit. |
| Malfunction of one of the LPS units. The red LED “ERR” of the malfunction LPS unit flashes fast. | Replace the whole LPS module. See "Lamp power supply", page 291 or "Lamp power supply (single module)", page 299. |

Code 5643: “lamp power supplies - communication failed with at least one lamp power supply” (Error)

| Situation | Solution |
|--|---|
| Main power cable disconnected from one of the LPS units (reference 1image 4-35). | Check if the main power cable is connected with the “MAINS INPUT” socket of the LPS unit. |
| Malfunction of one of the LPS units. The red LED “ERR” of the malfunction LPS unit flashes fast. | Replace the whole LPS module. See "Lamp power supply", page 291 or "Lamp power supply (single module)", page 299. |

Code 5646: “lamp - set lamp on failed” (Error)

| Situation | Solution |
|--|--|
| The lamp goes out immediately after the ignition or does not go on at all. SMPS and LPS seems to work normally. This situation can be the result of a bad lamp or SPG module. See chapter "Start Pulse Generator", page 311. | <ul style="list-style-type: none"> Install another xenon lamp in case the voltage on the “LAMP OUT” pins is 140 volt and you hear the SPG module three times clicking to ignite the lamp. Replace the SPG module in case the voltage value on the “LAMP OUT” pins is 140 volt and you do NOT hear the SPG module clicking to ignite the lamp. Replace the LPS modules in case the voltage value on the “LAMP OUT” pins is below 140 volt and the lamp is not ignited. <p>Note: The ambient noise must be low to hear the SPG clicking in an attempt to ignite the lamp.</p> |

Code 5647: “lamp - lamp is off due to an error” (Error)

| Situation | Solution |
|---|--|
| The Lamp Power Supply was triggered to switch off the lamp due to an error. | Check the projector log files for other listed errors and solve these errors first. |
| Malfunction Lamp Power Supply (LPS). | Replace the Lamp Power Supply unit. See "Lamp power supply", page 291 or "Lamp power supply (single module)", page 299.. |
| Defect Lamp installed. | Replace the Lamp. See "Lamps and lamp houses", page 93. |

Code 5654: “lamp run time - read failed” (Error)

| Situation | Solution |
|-------------------------------------|---|
| Lamp house not correctly inserted | Check if the lamp house is properly installed. Ensure that the three fixation screws (reference 1 image 4-17) of the lamp house are fastened. |
| Lamp Info Module with old firmware. | Check lamp info module firmware version in the "version info" area of the communicator. If mismatch is detected then run update. |
| Malfunction Lamp Info Module. | Replace the Lamp Info Module. See "Replacement of the Lamp Info module", page 113. |

Code 5657: “lamp run time - exceeds maximum” (Error)

| Situation | Solution |
|---|---|
| The lamp inside the lamp house has exceeded its maximum run time. | Replace the lamp and reset hours and bulb type. See "Lamps and lamp houses", page 93. |

Code 5658: “lamp run time - read limits failed” (Error)

| Situation | Solution |
|-------------------------------------|---|
| Lamp house not correctly inserted | Check if the lamp house is properly installed. Ensure that the three fixation screws (reference 1 image 4-17) of the lamp house are fastened. |
| Lamp Info Module with old firmware. | Check lamp info module firmware version in the "version info" area of the communicator. If mismatch is detected then run update. |
| Malfunction Lamp Info Module. | Replace the Lamp Info Module. See "Replacement of the Lamp Info module", page 113. |

Code 5659: “lamp run time - warning” (Warning)

| Situation | Solution |
|--|--|
| The lamp inside the lamp house is about to exceed its maximum run time. Status light lights up blue (notification state) | Replace the lamp as soon as possible. See "Replacement of the Lamp Info module", page 113. |

Code 5670: “dowser - set dowser open failed” (Error)

| Situation | Solution |
|---|--|
| Wire unit Dowser disconnected (reference 1 image 4-36). | Reconnect the dowser wire unit with the blue wire unit on the light processor unit (reference 1 image 4-36). |
| Wire unit Dowser disconnected from the Signal Backplane (reference 2 image 4-36). | Reconnect the blue wire unit of the Dowser with the Signal Backplane. |

| Situation | Solution |
|--------------------------------------|---|
| Blocked blade of the Dowser | Check if nothing is blocking the blade of the Dowser. Do NOT force the blade from the open position to the closed position or vice versa. |
| Damaged wire unit of the Dowser | Try to repair the damaged wire unit. If not possible replace the Dowser unit. See "Replacement of the dowser (shutter)", page 152. |
| Malfunction motor of the Dowser unit | Replace the Dowser unit. See "Replacement of the dowser (shutter)", page 152. |
| Malfunction Fan Control board | Replace the Fan Control board. See "Removing a board in the card cage", page 221. |

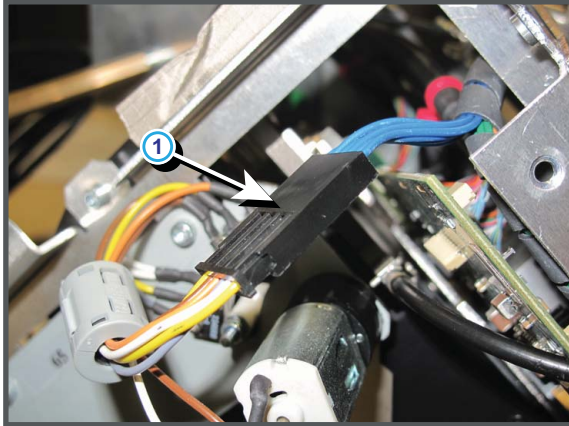
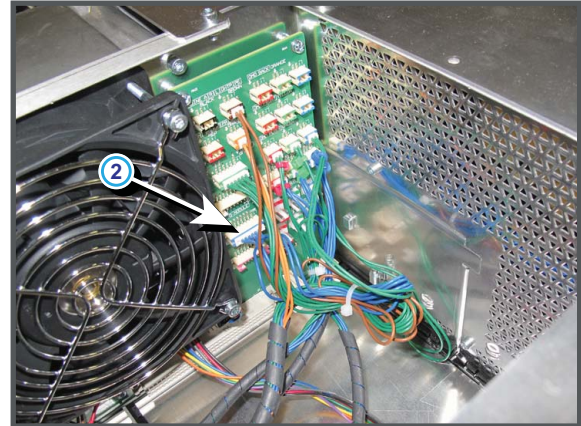

Image 4-36
Dowser connection



Code 5800: "ti-icp - system status = fail" (Error)

This is a generic TI error. Use the Communicator to make a detailed analysis. Go to *Diagnostics > Actual > Cinema Front End Status > Detailed status > Error Messages*. Possible error messages are:

| Situation | Solution |
|---|---|
| ICP self test - ICP frame memory test failed | Replace the ICP board. See "Removing a board in the card cage", page 221. |
| ICP self test - ICP data path signature test failed | Check the connections to the formatters. Replace the ICP board. See "Removing a board in the card cage", page 221. |
| ICP Normal Configuration Error | Replace the ICP board. See "Removing a board in the card cage", page 221. |
| ICP Boot Configuration Error | Replace the ICP board. See "Removing a board in the card cage", page 221. |
| FMT Normal Configuration Error | Replace the ICP board. See "Removing a board in the card cage", page 221. |
| FMT Boot Configuration Error | Replace the ICP board. See "Removing a board in the card cage", page 221. |
| FMT Satellite Configuration Error | Replace the ICP board. See "Removing a board in the card cage", page 221. |
| 1.20V Supply out of range | Replace the ICP board. See "Removing a board in the card cage", page 221. |
| 1.80V Supply out of range | Replace the ICP board. See "Removing a board in the card cage", page 221. |
| 2.50V Supply out of range | Replace the ICP board. See "Removing a board in the card cage", page 221. |
| 3.30V Supply out of range | Replace the ICP board. See "Removing a board in the card cage", page 221. |
| ICP FPGA Temperature out of range | Temperature on ICP is too high. Current active fans have errors. Solve the fan problem first. For a correct airflow, check if all covers are closed. Ambient temperature is too high. Reduce the ambient temperature. |
| ICP FMT FPGA Temperature out of range | Temperature on ICP is too high. Current active fans have errors. Solve the fan problem first. For a correct airflow, check if all covers are closed. Ambient temperature is too high. Reduce the ambient temperature. |
| ICP Flash Update Error | Replace the ICP board. See "Removing a board in the card cage", page 221. |

4. Troubleshooting

| Situation | Solution |
|-----------------------------|---|
| ICP real time clock error | <ol style="list-style-type: none"> 1. Clear the error by configuring the RTC (Real Time Clock) of the ICP. See user manual Communicator chapter "Set up of the ICP clock", choose the option UTC/GMT time calculated from current PC time current time. 2. If the error stays: <ul style="list-style-type: none"> - replace the RTC (Real Time Clock) battery of the ICP board. See "Replacement of the RTC battery of the ICP board", page 223. - Clear the projector error 5800 "ti-icp - system status = fail" with error message "ICP real time clock error" by configuring the RTC (Real Time Clock) of the ICP. See user manual Communicator chapter "Set up of the ICP clock", choose the option UTC/GMT time calculated from current PC time current time. - Clear the projector error 5834 "physical marriage tamper event" by remarrying the projector. See service manual chapter "Authorization to clear security warning on the projector". 3. If problem remains, replace the ICP board. See "Removing a board in the card cage", page 221 |
| Satellite Hardware Mismatch | Replace light processor assembly. See "Light processor assembly", page 135. |

Code 5801: "ti-link-decryptor - service door tamper event " (Error)

| Situation | Solution |
|---|---|
| A board in the Card Cage has been removed. | <p>Clear the security warning. See "Authorization to clear security warning on the projector", page 253.</p> <p>Brief procedure to clear the security warning:</p> <ol style="list-style-type: none"> 1. Ensure the cover plate of the Light Processor compartment is properly installed. 2. Ensure that all boards in the Card Cage are properly installed. 3. Start up the projector. 4. Initiate authorization by holding the security key in the security socket (image 4-37). 5. Enter the pin code within 5 seconds. |
| The cover plate of the Light Processor compartment has been removed. Security switches are activated (reference 1 & 2 image 4-38) | <p>Clear the security warning. See "Authorization to clear security warning on the projector", page 253.</p> <p>Brief procedure to clear the security warning:</p> <ol style="list-style-type: none"> 1. Ensure the cover plate of the Light Processor compartment is properly installed. 2. Ensure that all boards in the Card Cage are properly installed. 3. Start up the projector. 4. Initiate authorization by holding the security key in the security socket. 5. Enter the pin code within 5 seconds. |
| Defect security switches (reference 1 & 2 image 4-38). | If all compartments and devices are installed and security error will not authorize, replace DCI security switches. |
| Malfunction Signal Backplane | If switch replacement is not the solution, then replace Signal Backplane. See "Replacement of the signal back plane", page 239. |



Image 4-37
Dallas key slot

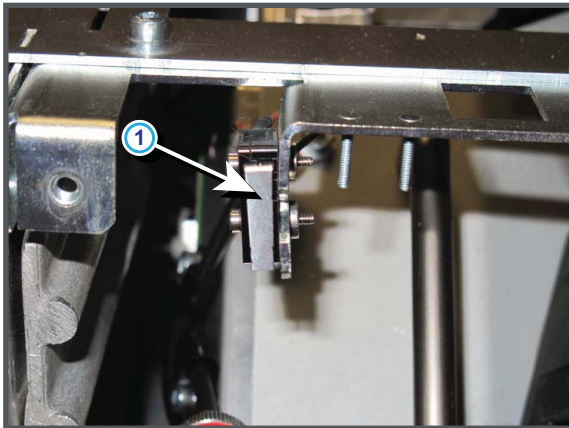
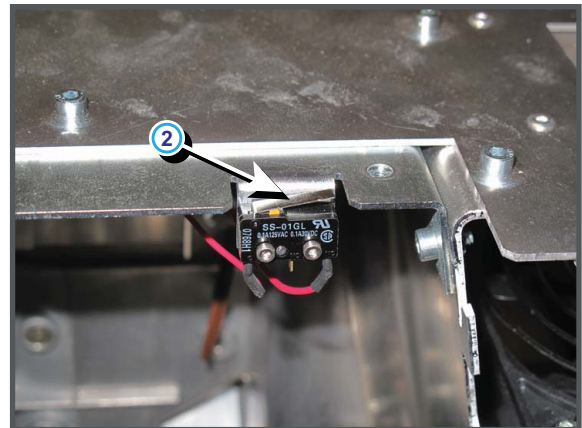

Image 4-38
Light processor cover tamper switches



Code 5807: “ti-icp - read system status failed” (Error)

The Barco controller can not read the status of the ICP.

| Situation | Solution |
|--|---|
| ICP board is not correctly inserted | Insert the ICP board properly. |
| ICP crash. The most left LED is not blinking | Restart the projector. |
| ICP is being upgrading | Wait until projector reset after the upgrade. |

Code 5812: “ti-icp - read satellite info failed” (Error)

| Situation | Solution |
|--|---|
| A wire unit to one of the formatters is not correctly connected to the Signal backplane (reference 1, 2, 3 for green on image 4-39). | Check the connections between the formatters and the Signal backplane on the Signal backplane side. |
| A wire unit on one of the formatters is not correctly connected (reference 4, 5, 6 for red on image 4-39) | Check the connections between the formatters and the Signal backplane on the formatter side. |



Image 4-39
Formatter connections

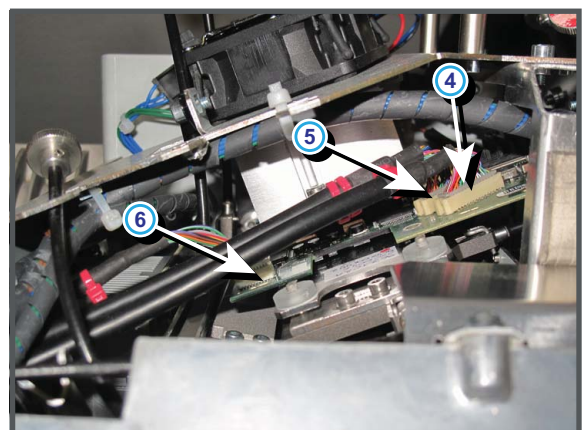

Code 5813: “ti-icp - satellite firmware mismatch” (Error)

This error can occur when you move ICP boards between projectors which have a different DMD configuration. (E.g. switching an ICP between a 1.2 and 0.98 inch system)

4. Troubleshooting

| Situation | Solution |
|----------------------|--|
| ICP software corrupt | <p>Reinstall the ICP software.</p> <p>Use the “DC update companion” to update the software. These software is part of the Communicator software.</p> <ul style="list-style-type: none"> • Start your communicator, make a connection and login as service technician. • Browse to Maintenance - Software upgade and click on Launch DC Update companion. Follow the instruction on the screen. <p>For more information on “launching DC update companion”, see Communicator’s User Guide. Continue then with “ICP software upgrade” as described in the same user guide.</p> |

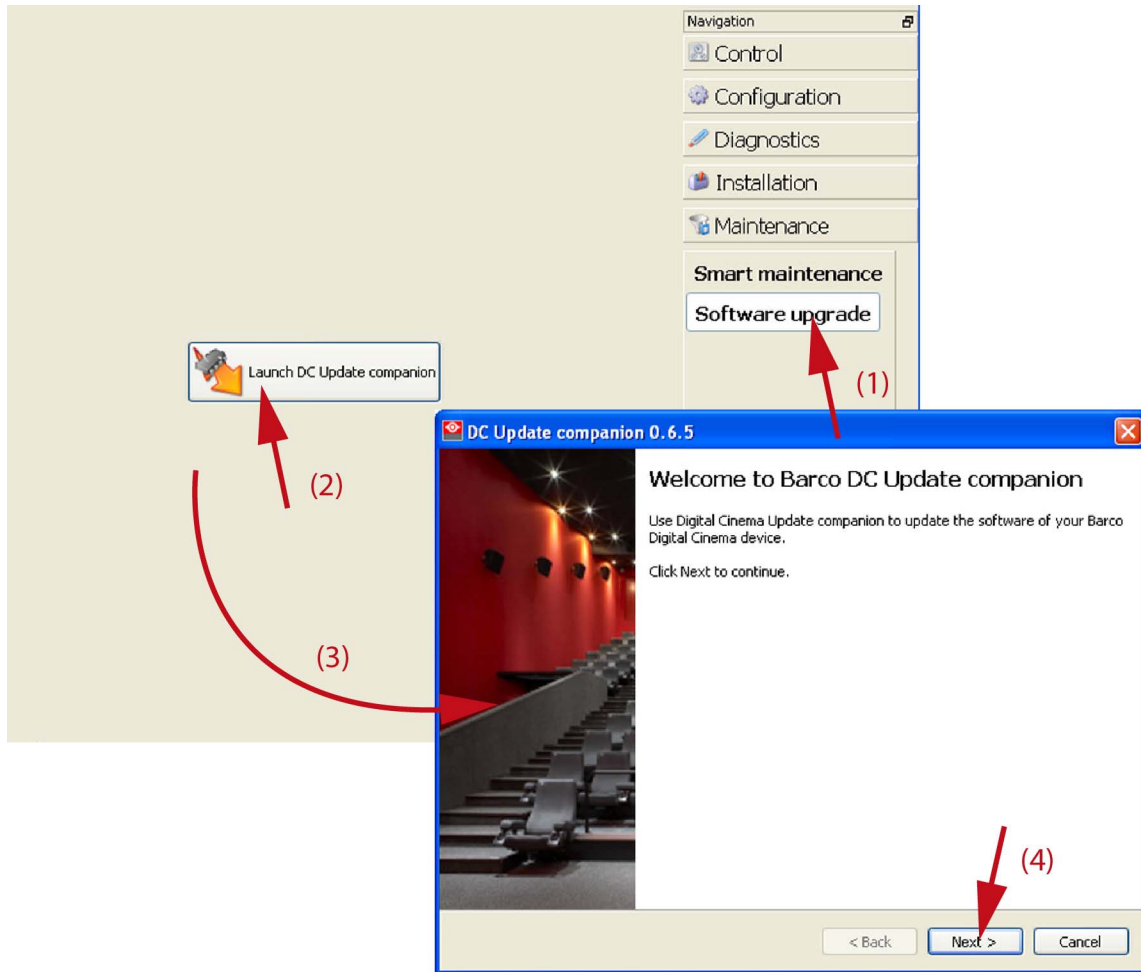

Image 4-40
Launch DC update companion

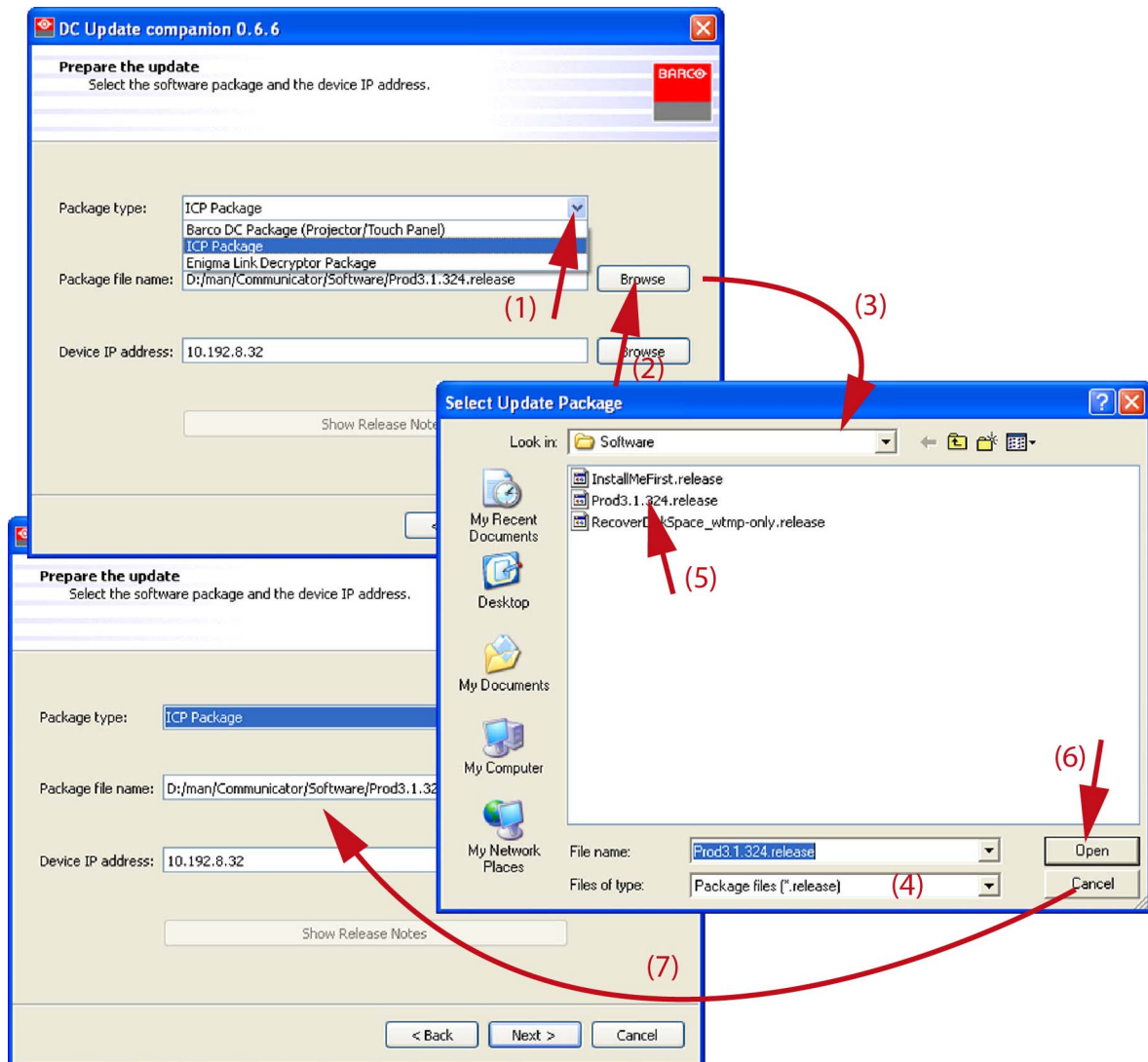

Image 4-41

Code 5814: “ti-icp - self test = fail” (Error)

| Situation | Solution |
|--|---|
| A wire unit to one of the formatters is not correctly connected to the Signal backplane (reference 1, 2, 3 for green on image 4-39). | Check the connections between the formatters and the Signal backplane on the Signal backplane side. The TI log file will indicate which formatter connection has failed If problem remains, replace ICP board. See "Removing a board in the card cage", page 221. |
| A wire unit on one of the formatters is not correctly connected (reference 4, 5, 6 for red on image 4-39). | Check the connections between the formatters and the Signal backplane on the formatter side. If problem remains, replace ICP board. See "Removing a board in the card cage", page 221. |

Code 5815: “ti-icp - certificate error” (Error)

| Situation | Solution |
|---|---|
| New ICP software version installed but no reboot of projector has happen. | Reboot projector |
| Error remains occurring after different boot cycles. | Replace ICP board. See "Removing a board in the card cage", page 221. |

Code 5816: “ti-icp - key error” (Error)

| Situation | Solution |
|---|---|
| New ICP software version installed but no reboot of projector has happen. | Reboot projector |
| Error remains occurring after different boot cycles. | Replace ICP board. See "Removing a board in the card cage", page 221. |

Code 5817: “ti-icp - icp board not detected” (Error)

| Situation | Solution |
|-----------------------------------|---------------------------|
| There is no ICP board installed. | Install an ICP board. |
| ICP board not correctly inserted. | Re-install the ICP board. |

Code 5830: “ti-link-decryptor - no communication” (Error)

| Situation | Solution |
|---|---|
| Link decryptor is not correctly seated. | Reseat the link decryptor. If problem remains, replace the link decryptor. |

Code 5831: “ti-link-decryptor - system error” (Error)

With the Communicator, go to *Diagnostics* → *Actual* → *Link Decryptor status* → *Error messages*

The following errors can occur:

| Error | Solution |
|---|--|
| Link decryptor - User loader integrity error | Replace link decryptor. See "Replacement of the Link Decryptor", page 251. |
| Link decryptor - Main application integrity error | Replace link decryptor. See "Replacement of the Link Decryptor", page 251. |
| Link decryptor - RNG hardware integrity error | Replace link decryptor. See "Replacement of the Link Decryptor", page 251. |
| Link decryptor - DRNG hardware integrity error | Replace link decryptor. See "Replacement of the Link Decryptor", page 251. |
| Link decryptor - RSA algorithm integrity error | Replace link decryptor. See "Replacement of the Link Decryptor", page 251. |
| Link decryptor - AES algorithm integrity error | Replace link decryptor. See "Replacement of the Link Decryptor", page 251. |
| Link decryptor - HMAC algorithm integrity error | Replace link decryptor. See "Replacement of the Link Decryptor", page 251. |
| Link decryptor - SHA algorithm integrity error | Replace link decryptor. See "Replacement of the Link Decryptor", page 251. |
| Link decryptor - TLS integrity error | Replace link decryptor. See "Replacement of the Link Decryptor", page 251. |
| Link decryptor - FPGA configuration integrity error | Replace link decryptor. See "Replacement of the Link Decryptor", page 251. |
| Link decryptor - FPGA cinelink 2 decryption integrity error | Replace link decryptor. See "Replacement of the Link Decryptor", page 251. |
| Link decryptor - Real time clock error | Replace link decryptor. See "Replacement of the Link Decryptor", page 251. |
| Link decryptor - FPGA configuration error | Replace link decryptor. See "Replacement of the Link Decryptor", page 251. |
| Link decryptor - FPGA temperature out of range | Temperature on the link decryptor is to high. Check for other fan or temperature error messages. Check if the front cover of the HDSDI module is closed. |
| Link decryptor - RNG Hardware duplicate output error | Replace link decryptor. See "Replacement of the Link Decryptor", page 251. |
| Link decryptor - DRNG Hardware duplicate output error | Replace link decryptor. See "Replacement of the Link Decryptor", page 251. |

| Error | Solution |
|--|---|
| Link decryptor - 1.20V supply out of range | Replace SMPS. See "Replacement of the Switched Mode Power Supply", page 289. Replace Signal backplane. See "Replacement of the signal back plane", page 239. Replace link decryptor. See "Replacement of the Link Decryptor", page 251. |
| Link decryptor - 1.80V supply out of range | Replace SMPS. See "Replacement of the Switched Mode Power Supply", page 289. Replace Signal backplane. See "Replacement of the signal back plane", page 239. Replace link decryptor. See "Replacement of the Link Decryptor", page 251. |
| Link decryptor - 2.50V supply out of range | Replace SMPS. See "Replacement of the Switched Mode Power Supply", page 289. Replace Signal backplane. See "Replacement of the signal back plane", page 239. Replace link decryptor. See "Replacement of the Link Decryptor", page 251. |
| Link decryptor - 3.30V regulator out of range | Replace SMPS. See "Replacement of the Switched Mode Power Supply", page 289. Replace Signal backplane. See "Replacement of the signal back plane", page 239. Replace link decryptor. See "Replacement of the Link Decryptor", page 251. |
| Link decryptor - Security tamper | The link decryptor has been tampered. Replace link decryptor. See "Replacement of the Link Decryptor", page 251. |
| Link decryptor - Top side security enclosure open | The top side enclosure has been tampered. Replace link decryptor. See "Replacement of the Link Decryptor", page 251. |
| Link decryptor - Bottom side security enclosure open | The bottom side enclosure has been tampered. Replace link decryptor. See "Replacement of the Link Decryptor", page 251. |
| Link decryptor - Software command Zeroization | Replace link decryptor. See "Replacement of the Link Decryptor", page 251. |
| Link decryptor - Physical marriage tamper | The ICP and/or link decryptor have been removed and inserted again. You need to remarry both. Start the clear security warning procedure. See "Authorization to clear security warning on the projector", page 253. |
| Link decryptor - Logical marriage tamper | The ICP and link decryptor are not a couple. This means one of both has been replaced. You need to marry both. Start the clear security warning procedure. See "Authorization to clear security warning on the projector", page 253. |
| Link decryptor - Service door tamper | The Card Cage cover has been removed. Clear the security warning. See "Authorization to clear security warning on the projector", page 253. The cover plate of the Light Processor compartment has been removed. Clear the security warning. See "Authorization to clear security warning on the projector", page 253. Defect security switches. If all compartments and devices are installed and security error will not authorize, replace DCI security switches. Malfunction Signal Backplane. If switch replacement is not the solution, then replace Signal Backplane. See "Replacement of the signal back plane", page 239. |
| Link decryptor - Service log error | The Security Log Error indicates that there is no more room to write log entries in the link decryptor log file. When this error is active, the DCI compliant Server needs to extract the log data (via ASM/TLS session) from the link decryptor Security Log. Reads of the security log by any other entity/means will not impact this error. This error will remain active until the Server reads enough log entries to create room for 512 log entries. This can take some time. Playback will be prohibited (black image) as long as this error is active. |
| Link decryptor - Security battery low warning | The battery of the link-decryptor is low. Leave the projector on for some time to recharge the battery. |
| Link decryptor - Security log warning | The security log warning indicates that there are less than 512 log entry locations available in the link decryptor log before the log is full. The attached server needs to read the log which will clear the log of the projector. When this warning is active, the DCI compliant server needs to extract the log data (via ASM/TLS session) from the link decryptor Security Log. This can take some time. Reads of the security log by any other entity/means will not impact this warning. |

Code 5832: "ti-link-decryptor - security tamper event" (Error)

| Situation | Solution |
|---------------------------------------|--|
| The link decryptor has been tampered. | Replace link decryptor. See "Replacement of the Link Decryptor", page 251. |

Code 5833: “ti-link-decryptor - logical marriage tamper event” (Error)

| Situation | Solution |
|--|---|
| The ICP and link decryptor are not a couple. | This means one of both has been replaced. You need to marry both. Start the clear security warning procedure. See "Authorization to clear security warning on the projector", page 253. Together with this error you will always have an error " <i>ti-link-decryptor physical marriage tamper event</i> ". Brief procedure to clear the security warning and marriage ICP and decryptor: <ol style="list-style-type: none"> 1. Ensure the cover plate of the Light Processor compartment is properly installed. 2. Ensure that all boards in the Card Cage are properly installed. 3. Start up the projector. 4. Initiate authorization by holding the security key in the security socket (image 4-37). 5. Enter the pin code within 5 seconds. |

Code 5834: “ti-link-decryptor - physical marriage tamper event” (Error)

| Situation | Solution |
|---|---|
| The ICP and/or link decryptor have been removed and inserted again. | You need to remarry both. Start the clear security warning procedure. See "Authorization to clear security warning on the projector", page 253. Brief procedure to clear the security warning and marriage ICP and decryptor: <ol style="list-style-type: none"> 1. Ensure the cover plate of the Light Processor compartment is properly installed. 2. Ensure that all boards in the Card Cage are properly installed. 3. Start up the projector. 4. Initiate authorization by holding the security key in the security socket (image 4-37). 5. Enter the pin code within 5 seconds. |

Code 5835: “ti-link-decryptor - security log is almost full” (Error)

| Situation | Solution |
|---|--|
| The security log almost full indicates that there are less than 512 log entry locations available in the link decryptor log before the log is full. The attached server needs to read the log which will clear the log of the projector. | When this warning is active, the DCI compliant server needs to extract the log data (via ASM/TLS session) from the link decryptor Security Log. This can take some time. Reads of the security log by any other entity/means will not impact this warning. |

Code 5836: “ti-link-decryptor - security log is full” (Error)

| Situation | Solution |
|--|---|
| The Security Log is full indicates that there is no more room to write log entries in the link decryptor log file. | When this error is active, the DCI compliant Server needs to extract the log data (via ASM/TLS session) from the link decryptor Security Log. Reads of the security log by any other entity/means will not impact this error. This error will remain active until the Server reads enough log entries to create room for 512 log entries. This can take some time. Playback will be prohibited (black image) as long as this error is active. |

Code 5837: “ti-link-decryptor - read system status failed ” (Error)

| Situation | Solution |
|---|--|
| Link decryptor is not correctly seated. | Reseat the link decryptor. If problem remains, replace link decryptor. See "Replacement of the Link Decryptor", page 251. |

Code 5850: “imb - no communication” (Error)

| Situation | Solution |
|-----------------------------------|--|
| No communication with media block | Check if the media block is well seated. Replace the media block. |

Code 5851: “imb - service door tamper event” (Error)

| Situation | Solution |
|--|--|
| A board in the Card Cage has been removed. | Clear the security warning. See "Authorization to clear security warning on the projector", page 253. Brief procedure to clear the security warning: <ol style="list-style-type: none"> 1. Ensure the cover plate of the Light Processor compartment is properly installed. 2. Ensure that all boards in the Card Cage are properly installed. 3. Start up the projector. 4. Initiate authorization by holding the security key in the security socket (image 4-37). 5. Enter the pin code within 5 seconds. |
| The cover plate of the Light Processor compartment has been removed. Security switches are activated (reference 1 & 2 image 4-38). | Clear the security warning. See "Authorization to clear security warning on the projector", page 253. Brief procedure to clear the security warning: <ol style="list-style-type: none"> 1. Ensure the cover plate of the Light Processor compartment is properly installed. 2. Ensure that all boards in the Card Cage are properly installed. 3. Start up the projector. 4. Initiate authorization by holding the security key in the security socket (image 4-37). 5. Enter the pin code within 5 seconds. |
| Defect security switches (reference 1 & 2 image 4-38). | If all compartments and devices are installed and security error will not authorize, replace DCI security switches. |
| Malfunction Signal Backplane | If switch replacement is not the solution, then replace Signal Backplane. See "Replacement of the signal back plane", page 239. |

Code 5853: “imb - logical marriage tamper event” (Error)

| Situation | Solution |
|--|---|
| The ICP and Mediablock are not a couple. | This means one of both has been replaced. You need to marry both. Start the clear security warning procedure. See "Authorization to clear security warning on the projector", page 253. Together with this error you will always have an error " <i>imb - physical marriage tamper event</i> ". |

Code 5854: “imb - physical marriage tamper event” (Error)

| Situation | Solution |
|--|---|
| The ICP and/or IMediablock have been removed and inserted again. | You need to remarry both. Start the clear security warning procedure. See "Authorization to clear security warning on the projector", page 253. |

Code 5960: “light pipe - temperature too high” (Error)

This error code is probably preceded by the warning code 5961: “light pipe - temperature high”. The same troubleshooting table can be applied.

Code 5961: “light pipe - temperature high” (Warning)

| Situation | Solution |
|---|--|
| Damaged wire unit of the temperature sensor which measures the temperature of the cooling block of the light pipe entrance. | <ol style="list-style-type: none"> 1. Repair the wire unit. 2. If not repairable, replace the whole wire unit and temperature sensor. |
| Defect temperature sensor on the cooling block of the light pipe entrance. | Replace the temperature sensor. |
| Misalignment of the lamp inside the lamp house. | <ol style="list-style-type: none"> 1. Readjust the Z-alignment of the lamp. See "Realignment of the lamp in its reflector", page 111. 2. Replace the lamp house with a new lamp house. See "Removal of the lamp house", page 96. |
| Misalignment of the cold mirror. | Readjust the cold mirror. See "Cold mirror assembly", page 123. |

4. Troubleshooting

Code 5964: “light pipe - temperature sensor open” (Error)

| Situation | Solution |
|---|---|
| Wire unit (reference 1 image 4-42) of the temperature sensor is disconnected from the Signal Backplane. | Plug in the wire unit of the temperature sensor into its socket on the Signal Backplane. |
| Damaged wire unit of the temperature sensor which measures the temperature of the cooling block of the light pipe entrance. | <ol style="list-style-type: none"> 1. Repair the wire unit. 2. If not repairable, replace the whole wire unit and temperature sensor. |
| Defect temperature sensor on the cooling block of the light pipe entrance. | Replace the temperature sensor. |

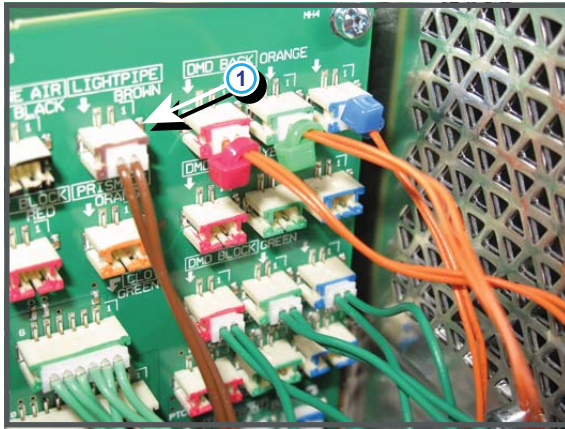

Image 4-42
Light pipe temperature sensor connection

Code 5965: “light pipe - temperature sensor short” (Error)

| Situation | Solution |
|--|---|
| Damaged insulation of the wire unit of the temperature sensor (reference 1 image 4-42) which measures the temperature of the cooling block of the light pipe entrance. When disconnecting the wire unit of the temperature sensor from the Signal backplane, the error code is changed to “light pipe - temperature sensor open 5964”. | <ol style="list-style-type: none"> 1. Repair the insulation of the wire unit using shrink sleeve. 2. If not repairable, replace the whole wire unit and temperature sensor. |
| Defect temperature sensor on the cooling block of the light pipe entrance. When disconnecting the wire unit (reference 1 image 4-42) of the temperature sensor from the Signal backplane, the error code is changed to “light pipe - temperature sensor open 5964”. | Replace the temperature sensor. |

Code 6050: “dmd - temperature hardware protection warning” (Warning)

| Situation | Solution |
|-----------------------|--|
| DMD temperature low. | Make sure that the ambient temperature is within specs. Let the projector acclimate to the normal room temperature which should be higher than 10°C (50°F) and lower than 35°C (95°F). Do not ignite the lamp, otherwise there is a risk for condensate. |
| DMD temperature high. | Check all cooling systems: Air extraction system, dust filters, ... |

Code 6061: “+24v - voltage high” (Warning)

| Situation | Solution |
|--|--|
| Malfunction Fan Control board or SMPS board. | Measure on the Signal Backplane the +24V voltage on pin 9, 10, 11 or 12 of the connector of the black wire unit which comes from the SMPS board. See image 4-43. If the measured voltage is about 24V then replace the Fan Control board. See "Removing a board in the card cage", page 221. Otherwise replace the SMPS board. See "Replacement of the Switched Mode Power Supply", page 289. |

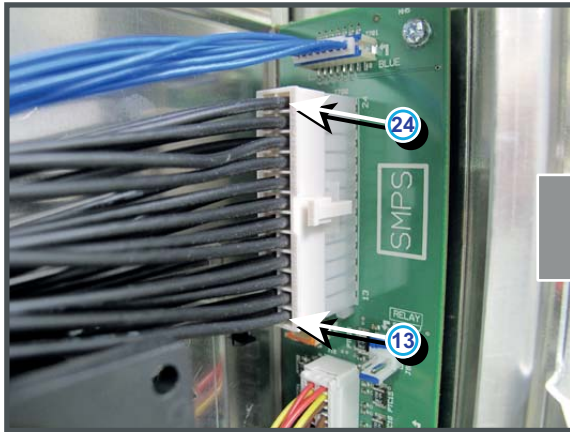
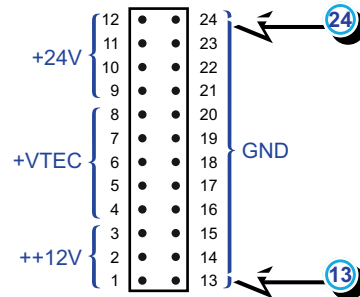

Image 4-43

**Code 6062: “+24v - voltage too low” (Error)**

This error code is probably preceded by the warning code 6063: “+24v - voltage low”. The same troubleshooting table can be applied.

Code 6063: “+24v - voltage low” (Warning)

| Situation | Solution |
|--|---|
| Malfunction Fan Control board or SMPS board. | Measure on the Signal Backplane the +24V voltage on pin 9, 10, 11 or 12 of the connector of the black wire unit which comes from the SMPS board. See image 4-43. If the measured voltage is about 24V then replace the Fan Control board. See "Removing a board in the card cage", page 221. Otherwise replace the SMPS board. See "Replacement of the Switched Mode Power Supply", page 289. |
| Short circuit or bad connection. | <ol style="list-style-type: none"> 1. Check the Signal Backplane for bad connections. Ensure that all wire units are well connected. (Note that the +24V supply is generated on the SMPS board and enters the Fan Control board and Cinema Control board via the Signal Backplane) 2. Check the wiring of the Anode fan for short circuits. 3. Check the wiring of the Cathode fan for short circuits. |

Code 6071: “++12v - voltage high” (Warning)

| Situation | Solution |
|--|---|
| Malfunction Fan Control board or SMPS board. | Measure on the Signal Backplane the ++12V voltage on pin 1, 2 or 3 of the connector of the black wire unit which comes from the SMPS board. See image 4-43. If the measured voltage is about 12V then replace the Fan Control board. See "Removing a board in the card cage", page 221. Otherwise replace the SMPS board. See "Replacement of the Switched Mode Power Supply", page 289. |

Code 6073: “++12v - voltage low” (Warning)

| Situation | Solution |
|--|---|
| Malfunction Fan Control board or SMPS board. | Measure on the Signal Backplane the ++12V voltage on pin 1, 2 or 3 of the connector of the black wire unit which comes from the SMPS board. See image 4-43. If the measured voltage is about 12V then replace the Fan Control board. See "Removing a board in the card cage", page 221. Otherwise replace the SMPS board. See "Replacement of the Switched Mode Power Supply", page 289. |
| Short circuit or bad connection. | Check the Signal Backplane for bad connections. |

Code 6082: “lens motors - voltage too low” (Error)

| Situation | Solution |
|--|---|
| The supply voltage for the lens motors is below its minimum. | Measure on the Signal Backplane the +24V voltage on pin 9, 10, 11 or 12 of the connector of the wire unit which comes from the SMPS board. See image 4-43. (The supply voltage for the lens motors is derived form the +24V on the Cinema Controller board. The +24V supply is generated on the SMPS board and enters the Fan Control board and Cinema Control board via the Signal Backplane.) If the measured voltage is about 24V then: <ol style="list-style-type: none"> reseat the Cinema Controller board. See "Removing a board in the card cage", page 221. if the problem remains, replace the Cinema Controller board. If the measured voltage is not OK then: <ol style="list-style-type: none"> Check the Signal Backplane for bad connections or short circuits. Ensure that all wire units are well connected. Check the wiring of the Anode fan for short circuits. Check the wiring of the Cathode fan for short circuits. replace the Fan Control board. See "Removing a board in the card cage", page 221. replace the SMPS board. See "Replacement of the Switched Mode Power Supply", page 289. |

Code 6123: “icp fan - speed low” (Warning)

| Situation | Solution |
|--|---|
| Wire unit (reference 2 image 4-44) disconnected from the Signal Backplane. | Remove the Card Cage cover from the projector and check if the wire unit (reference 2 image 4-44) is inserted in the Signal Backplane. |
| Blocked fan (reference 1 image 4-44). | Remove the Fan Control board and look inside the compartment to check if the fan is not blocked. Unblock the fan. Ensure that the fan can turn freely. See "Removing a board in the card cage", page 221. |
| Damaged wire unit. | Remove the Fan Control board and look inside the compartment to check the wire unit of the ICP fan. Repair if possible, otherwise replace with new one. See "Integrated cinema processor fan", page 338. |
| Malfunction Fan Control board. | Replace the Fan Control board. See "Removing a board in the card cage", page 221. |
| Fan end of life. | Replace the fan. See "Integrated cinema processor fan", page 338.. |

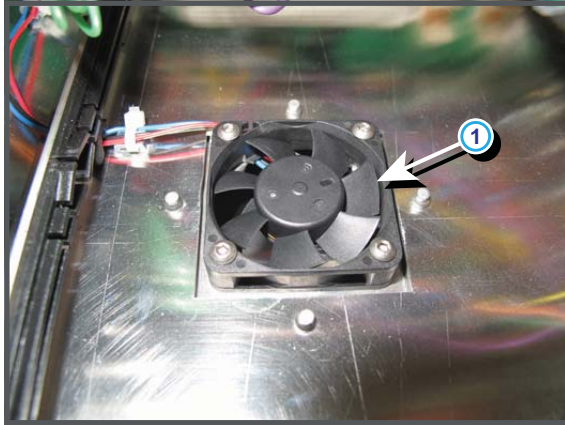
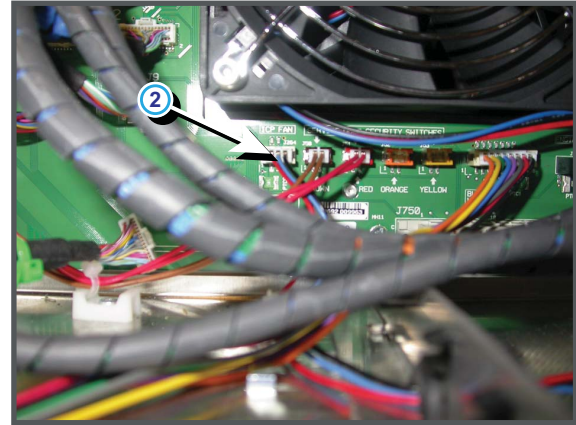

Image 4-44
ICP fan connection



Code 6131: “icp fan - voltage high” (Warning)

| Situation | Solution |
|--|--|
| Malfunction Fan Control board or SMPS board. | <p>Measure on the Signal Backplane the ++12V voltage on pin 1, 2 or 3 of the connector of the black wire unit which comes from the SMPS board. See image 4-43.</p> <p>If the measured voltage is about 12V then replace the Fan Control board. See "Removing a board in the card cage", page 221. Otherwise replace the SMPS board. See "Replacement of the Switched Mode Power Supply", page 289.</p> |

Code 6133: “icp fan - voltage low” (Warning)

| Situation | Solution |
|--|--|
| Malfunction Fan Control board or SMPS board. | <p>Measure on the Signal Backplane the ++12V voltage on pin 1, 2 or 3 of the connector of the black wire unit which comes from the SMPS board. See image 4-43.</p> <p>If the measured voltage is about 12V then replace the Fan Control board. See "Removing a board in the card cage", page 221. Otherwise replace the SMPS board. See "Replacement of the Switched Mode Power Supply", page 289.</p> |
| Short circuit or bad connection. | Check the Signal Backplane for bad connections. |
| Damaged insulation of the wire unit of the fan (reference 1 & 2 image 4-44) Note that this fan is in the Card Cage compartment underneath the Fan & Motor Control board. | <p>Check the insulation of the wire unit of the fan.</p> <ol style="list-style-type: none"> 1. Repair the insulation of the wire unit using shrink sleeve. 2. If not repairable, replace the whole wire unit and/or fan. See "Integrated cinema processor fan", page 338. |

Code 6200: “maintenance - maintenance required” (Notification)

| Situation | Solution |
|---------------------------------|--|
| Projector requires maintenance. | <p>Go to the menu "Maintenance → Smart maintenance" in the Communicator software.</p> <p>See also maintenance program of the projector (included in the service manual).</p> |

Code 6210: “lens - no lens parameter file has been activated” (Warning)

| Situation | Solution |
|--|--|
| No lens parameter file has been activated. | <p>Select a suitable lens parameter file for the installed lens using the Communicator software.</p> <p>>Installation >Advanced >Lens parameters >Select</p> |

4.2 Log files

Creating and downloading log files

A diagnostic package can be created with the Communicator software. Start up the software and go to *Diagnostics* → *Package*. A zip file will be created with the following information:

- ICP log file
- Security log file
- Projector log

These log files can be read with the Diagnostic package reader which was delivered as separate program together with the Communicator software. For more information about the use of this Diagnostic package reader, consult the User Guide of the Communicator software.

ICP Log File

Records events listed below:

- Handshakes with server
- TI system initialization
- Reading of TI board status
- Opening of TCP connection
- Failure of TI boards

Security Log File

Records events listed below:

- Monitoring of security switches
- Monitoring of key exchange
- Authorizing of Dallas key

Projector Log

Records events listed below:

- Lamp control commands
- Booting of Barco software
- Detection of TI boards
- Log on details of users
- Detection of Barco modules (LPS, FCB, etc.)

DP2K Log file analysis

Example of log file content

```
Dec 31 17:00:17 localhost local0.info license-manager[221]: main - starting application (version 1.0.1)
Dec 31 17:00:17 localhost local0.info router[224]: main - starting application (version 1.0.1)
Dec 31 17:00:17 localhost local0.info router[231]: network - wan ip-address is 0.0.0.0
Dec 31 17:00:18 localhost local0.info dp60[233]: main - starting application (version 1.0.7)
Dec 31 17:00:18 localhost local0.info dp60[233]: main - projector type is "DP2K-20C"
Dec 31 17:00:21 localhost local0.info dp60[233]: ti-icp - wait until ready
Dec 31 17:00:34 localhost local0.info dp60[233]: system - synchronize date to 20100406124925
Apr 6 12:49:25 localhost local0.info dp60[233]: system - ti-link-decryptor login started...
Apr 6 12:49:41 localhost local0.info dp60[233]: system - ti-link-decryptor login successful
Apr 6 12:49:41 localhost local0.info dp60[233]: system - load lens encoder file "R9855931"
Apr 6 12:49:41 localhost local0.info dp60[233]: command (port = internal) - execute lens file '.init'
...
```

Format :

```
'Time' localhost 'facility code'.'severity code' 'component name' ['pid']: 'message'
```

Where :

- 'Time' = the time when the event occurred
- 'facility code' = component level that generates a log message
- 'severity code' = the severity can be : info – debug – warning – alert – err.
- 'component name' = component name that generates a log message.
 - dp60 = main process
 - kernel = Linux kernel
 - router = component which manages the router
 - TI_marriage = component which handles the marriage
 - clo = component which handles Light Sensor logic
 - license-manager = internal license manager
 - crypto memory = process which handles communication with crypto memory module (ID card)
- 'pid' = Process identifier. The internal process identifier, of the component generating the log message.
- 'message' = The actual error message.

The Barco controller inserts every hour an unique entry in the Barco log file and in the TI log file. This is done to be able to synchronize events in both log files, when the clocks are not aligned. It will also be used for a tool, that is still to be implemented, that will merge both log files, to make better analysis.

Example of such an entry :

```
Feb 3 02:41:16 localhost local0.info dp60[233]: log mark - 0000003c1b84 - 8
```

Each Barco entry into a TI log is proceeded with a B.

What does the id means (as in the example) :

- 0000003c
 - the first 4 bytes give a hex interpretation of how many time the system has been booted.
 - 3c hex is 60 in decimal. It means that this system has been booted 60 times. Every boot cycle increases the timer with 1.
- 1b84 = the last two bytes, are random unique 2 bytes.
- 8 = the last digit indicates the number of hours passed in this boot cycle (in a decimal value). Every boot cycle resets this number to 0.

Ethernet connection messages in log file (some examples).

```
Apr 6 14:05:19 localhost local0.info dp60[233]: main - closing connection of
150.158.197.64:43680 (keep-alive time expired)
```

→ after 15 minutes of inactivity projector will close connection.

```
Apr 6 14:08:55 localhost local0.info dp60[233]: main - accepted connection from
150.158.192.133:43680
```

→ connection from communicator, from pc with ip address 150.158.192.133

```
Apr 6 14:08:58 localhost local0.info dp60[233]: log (port = 150.158.192.133:43680:1e) - lo-
gon-phmt-barco-default
```

→ communicator inserts in log file, who logged on to projector

```
Apr 6 14:09:07 localhost local0.info dp60[233]: command (port = 150.158.192.133:43680:1e) - set
lamp on
```

→ Command messages also indicate originator.

```
Apr 6 14:09:07 localhost local0.info dp60[233]: system - load fcb file "lamp-on"
```

→ on fan controller board, lamp-on state is set.

External commands received by the Barco controller are preceded with the command (port = xxx) string

Where xxx can be :

- /dev/ttyS0:0 = Command comes from the serial connection labeled ("RS232 IN"). That can be from a touch panel which is connected through a RS232 cable, or from a communicator which is connected serially.
- /dev/ttyS2:0 = Command comes from a touch panel attached with a dedicated cable to the back of the projector (touch panel input).
- /dev/ttyS3:0 = Command comes from the TI board. This is typically a command that is part of a macro stored on that board.
- 10.36.62.17:43680 = Command comes from a remote machine with indicated IP address, followed by the local of the remote machine that send this command internal. The command is initiated internally, due to an internal reason.
- button = button is triggered from the keypad, attached to the projector.

Some examples :

4. Troubleshooting

- `command (port = /dev/ttyS2:0) - set network ip-address to 10.140.162.141 (dhcp off)` = From the touch panel, the IP address of the projector was set to 10.140.162.141
- `command (port = 10.36.62.17:43680) - set network ip-address to 10.36.62.62 (dhcp off)` = From a device with IP address 10.36.63.17, the IP address of the projector was changed to 10.36.63.17
- `command (port = /dev/ttyS0:0) - set dowser open.` = From a touch panel or PC, connected serially (connector labeled "Touch panel"), the dowser was set to open.
- `command (port = /dev/ttyS0:0) - set lamp off` = From a touch panel or PC, connected serially (connector labeled "Touch panel"), the lamp was powered off.
- `command (port = internal) - set lamp off` = For an internal reason the state of the lamp was set to off.
- `command (port = button) - set dowser closed` = The dowser was closed from the keypad.

The error messages are explained in the troubleshooting list - code 5831

ICP log files

Example of log file content :

```
2010/04/06 09:02:40.964797 I ICP application 1.2(126) init Shows the ICP package
2010/04/06 09:02:40.980964 I successfully initialized the LoginLevelProtection mutex
2010/04/06 09:02:41.039022 I Autotiming initialized
2010/04/06 09:02:41.049829 I Autotiming using VSyncs
2010/04/06 09:02:41.051245 I Started Autotiming Port threads
2010/04/06 09:02:41.051755 I Autotiming started
2010/04/06 09:02:41.052149 I Port thread running
2010/04/06 09:02:41.052897 I Port thread running
2010/04/06 09:02:43.632304 I Started Autotiming Main thread
2010/04/06 09:02:43.633017 D Autotiming thread running
2010/04/06 09:02:43.633476 D Autotiming: blank the image
2010/04/06 09:02:43.792939 D Autotiming: unblank the image
...
```

Format

'Date Time' 'Severity' 'message'

Where :

- 'Date Time' = the time when the event occurred.
- 'Severity' = One character severity indication can be : 'D' (Debug) – "E" (Error) – "I" (Informational) - "U" (User).
- 'message' = The actual error message.

Example :

```
24.03.2010 17:17:12.185 TPPL = 2848, APPL = 2048, TLPF = 4095, ALPF = 128
```

This line is entered when the auto timing on the ICP computes values that are not within valid ranges.

Where :

- TPPL = Total Pixels Per Line
- APPL = Active Pixels Per Line
- TLPF = Total Lines Per Frame
- ALPF = Active Lines Per Frame
- 512 <= APPL <= TPPL <= 8191
- 288 <= ALPF <= TLPF <= 4095

In this example ALPF = 128 which is less than the minimum of 288. When this happens, auto timing will attempt to blank the image.

5. REMOVAL AND INSTALLATION OF PROJECTOR COVERS

About this chapter

Most maintenance and servicing procedures demand removing one or more of the projector covers to gain access to the parts to maintain or to service. To avoid redundancy, all procedures about cover removing or installing are grouped together in this chapter. The maintenance and servicing procedures also refer to this chapter if required. The procedures in this chapter describe, with detailed step by step actions and illustrations, how to remove or install the projector covers. Note that some covers may only be removed by qualified service personnel, see remarks above each procedure.



WARNING: Always switch off the projector and unplug the power cord before removing one of the covers, unless otherwise stated.

Overview

- Removal of the lamp cover
- Removal of the input cover
- Removal of the front cover
- Removal of the side cover
- Removal of the rear cover
- Removal of the top cover
- Open the sealed compartment
- Close the sealed compartment
- Installation of the top cover
- Installation of the rear cover
- Installation of the side cover
- Installation of the front cover
- Installation of the input cover

5.1 Removal of the lamp cover



WARNING: This procedure may only be performed by qualified technical service personnel.

Necessary tools

Flat screw driver.

How to remove the lamp cover of the projector?

1. Release the two captive screws at the right side, top and bottom, of the lamp cover, using a flat screw driver.

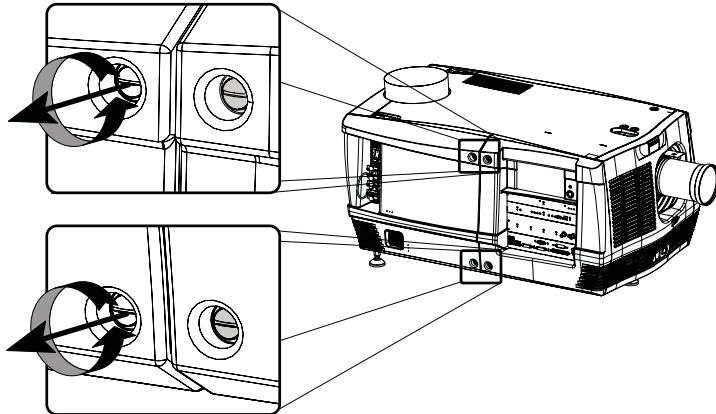

Image 5-1
Release lamp cover

2. Remove the lamp cover from the projector doing the following:
 - a) gently pull out the left bottom corner (A) of the lamp cover,
 - b) then gently pull out the left top corner (B) of the lamp cover,
 - c) then move the lamp cover away from the projector (C).

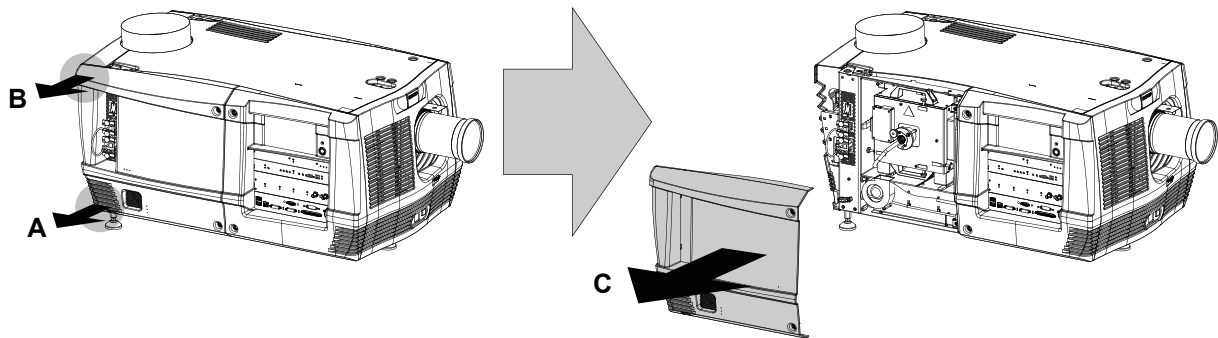

Image 5-2
Remove lamp cover

5.2 Removal of the input cover



WARNING: This procedure may only be performed by qualified technical service personnel.

Necessary tools

Flat screw driver.

How to remove the input cover of the projector?

1. Release the two captive screws at the top and bottom left side of the input cover, using a flat screw driver.

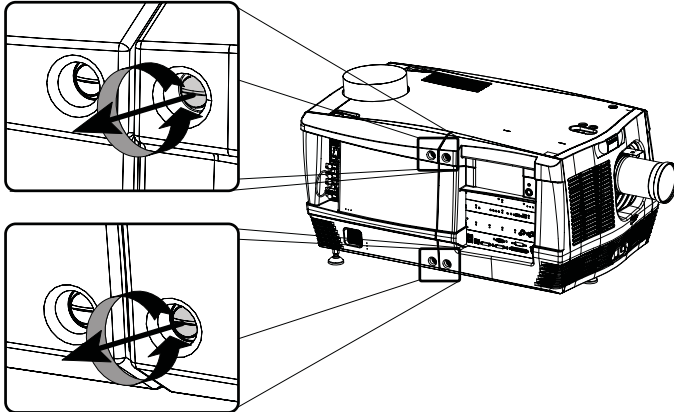

Image 5-3
Release input cover

2. Remove the input cover from the projector doing the following:
 - a) gently pull out the right bottom corner (A) of the input cover,
 - b) then gently pull out the right top corner (B) of the input cover,
 - c) then move the input cover away from the projector (C).

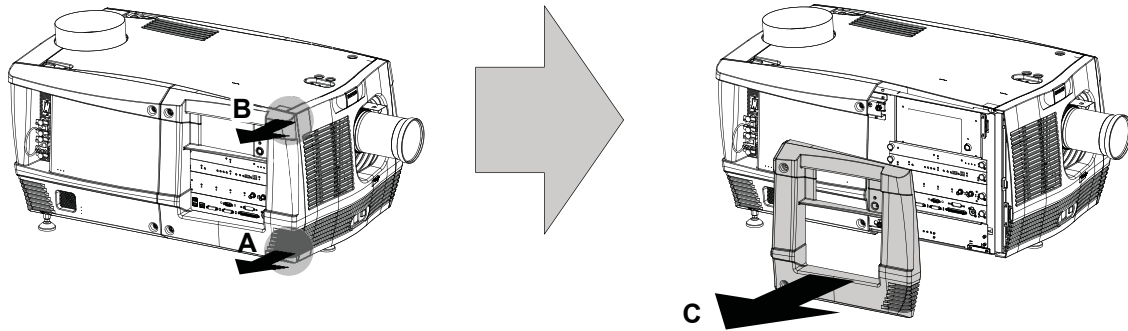

Image 5-4
Remove input cover

5.3 Removal of the front cover



The input cover and the lens have to be removed before removing the front cover. See procedures "Removal of the input cover", page 79, and "Lens removal", page 189.

Necessary tools

Flat screw driver

How to remove the front cover of the projector

1. Check if the input cover and the lens are removed.
2. Remove the rubber dust ring from the lens holder. See the detail at the right side of image 5-5.
3. Release the captive screw at the middle bottom of the front cover, using a flat screw driver.

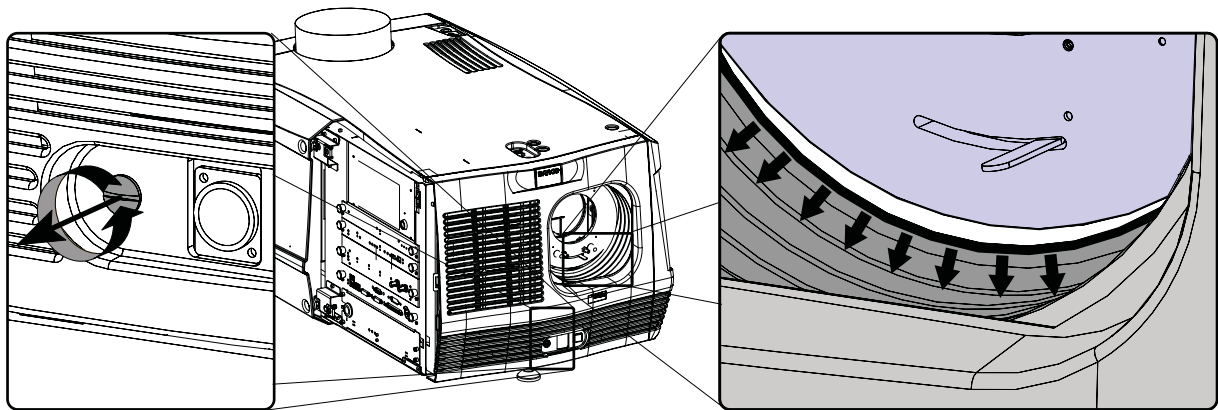

Image 5-5
Release front cover

4. Remove the front cover from the projector doing the following:
 - a) standing in front of the projector, pull the upper right corner (A) of the front cover toward you until the latch releases,
 - b) pull the lower right corner (B) of the front cover toward you until the latch releases,
 - c) then move the front cover away from the projector.

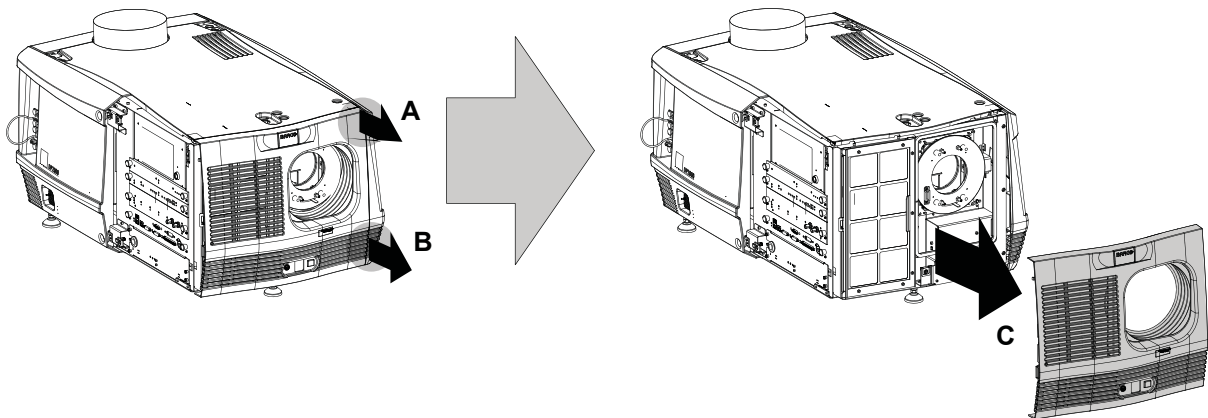

Image 5-6
Remove front cover

5.4 Removal of the side cover

Necessary tools

Flat screw driver.

How to remove the side cover of the projector?

1. Release the captive screw at the middle bottom of the side cover, using a flat screw driver.

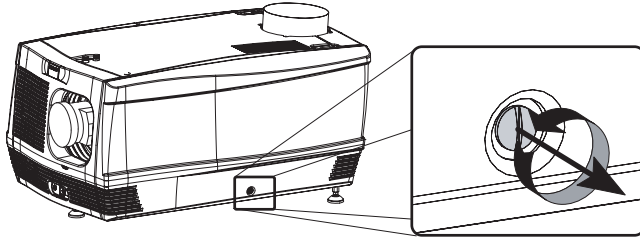

Image 5-7

2. Remove the side cover from the projector doing the following:
 - a) gently pull out the bottom corners (A) of the side cover,
 - b) then gently pull out the top corners (B) of the side cover,
 - c) then move the side cover away from the projector (C).

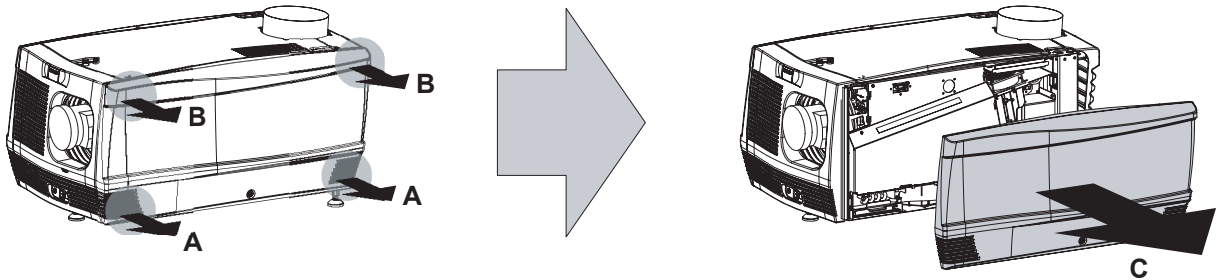

Image 5-8

5.5 Removal of the rear cover



WARNING: This procedure may only be performed by qualified technical service personnel.

Necessary tools

Flat screwdriver.

How to remove the rear cover from the projector?

1. Release the two captive screws at the bottom corners of the rear cover, using a flat screw driver.

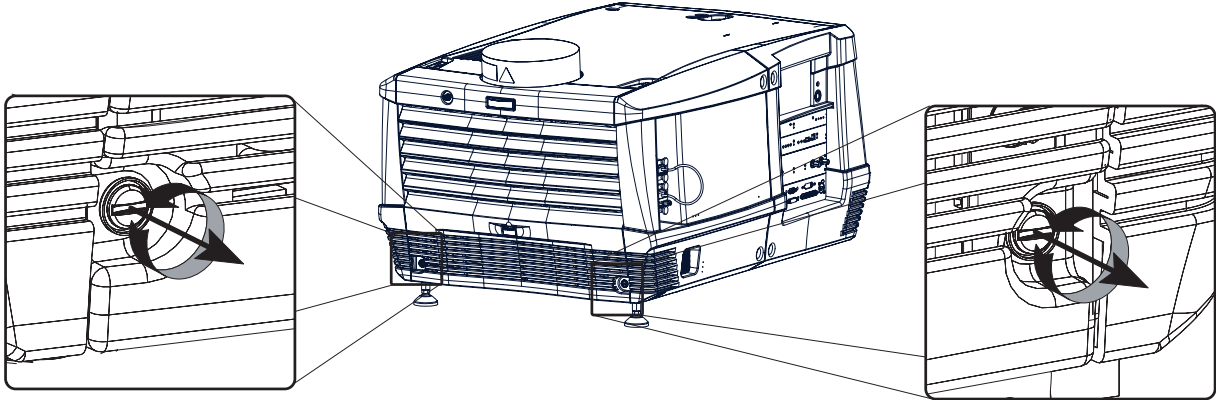

Image 5-9
Release rear cover

2. Remove the rear cover of the projector doing the following:
 - a) gently pull out the top corners of the rear cover,
 - b) then move the rear cover away from the projector.

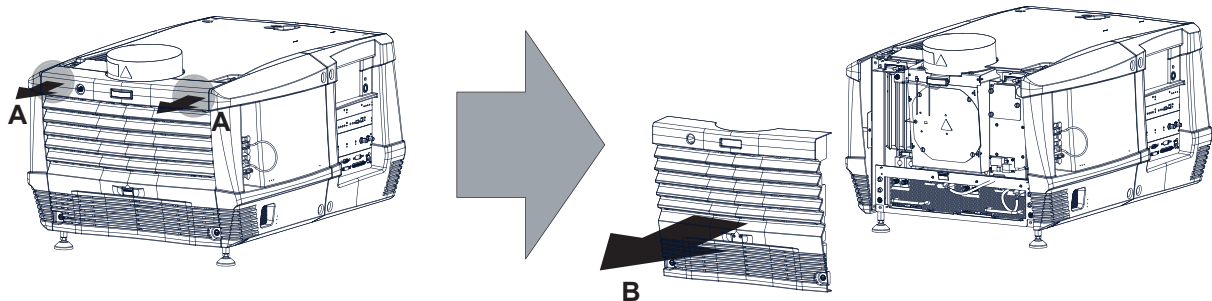

Image 5-10
Remove rear cover

5.6 Removal of the top cover



WARNING: This procedure may only be performed by qualified technical service personnel.



All side covers, front cover and back cover have to be removed before removing the top cover.

Necessary tools

Allen key 3mm

How to remove the top cover of the projector?

1. After all side covers, front and back cover are removed, turn all 3 fixation screws.

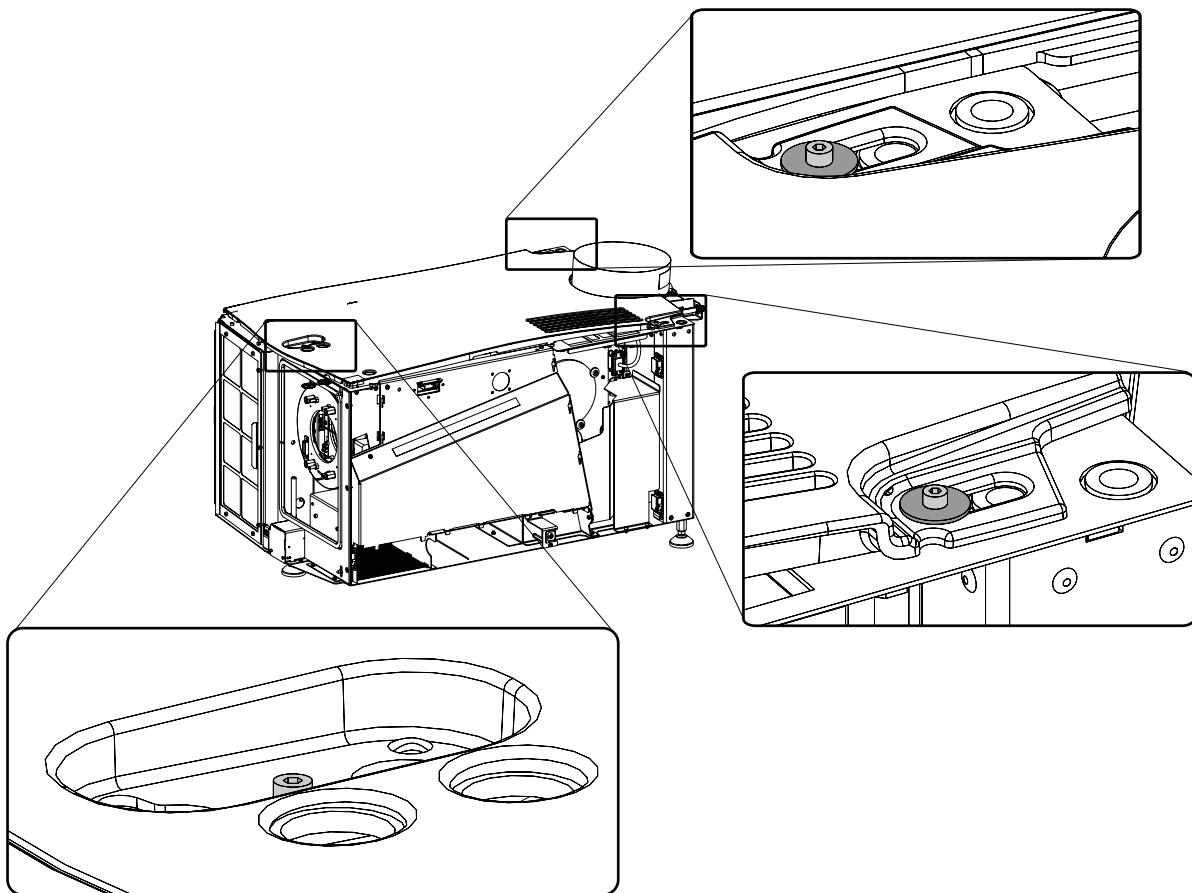

Image 5-11
Top cover removal

2. Left up the top cover and take it off.

5. Removal and installation of projector covers

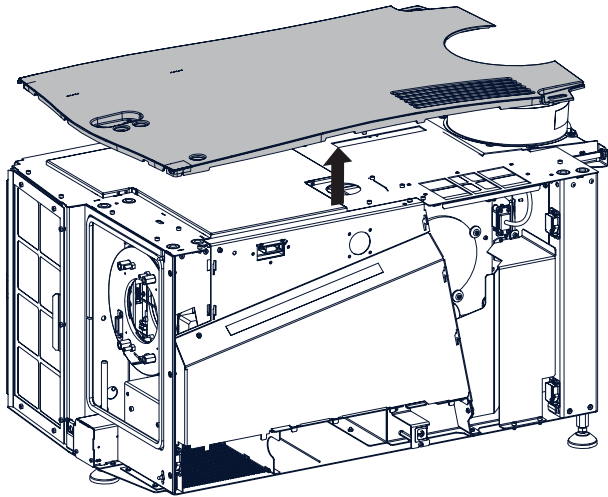

Image 5-12
Top cover removal

5.7 Open the sealed compartment



This procedure assumes that the left side cover of the projector is already removed.

Necessary tools

Allen wrench 3 mm

How to open the sealed compartment of the Light Processor Unit?

1. Release the three hexagon head cap screws as illustrated. Use for that a 3 mm Allen wrench.
Note: A washer is mounted between the plate and the screw head.

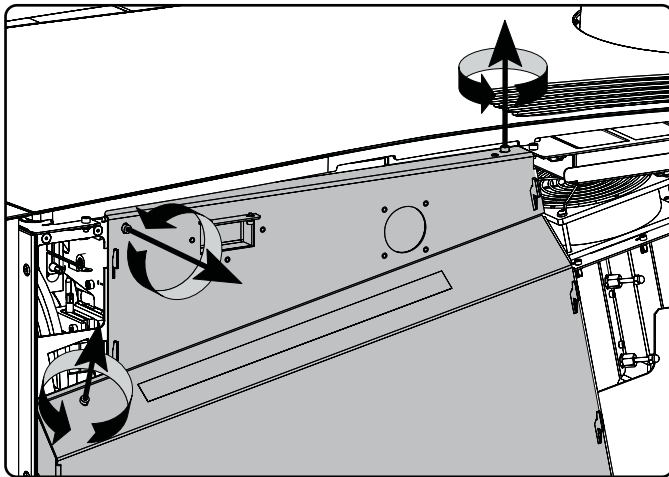

Image 5-13

2. Lift up the cover plate slightly, using the two lower lips provided, and then remove the cover plate away from the projector.

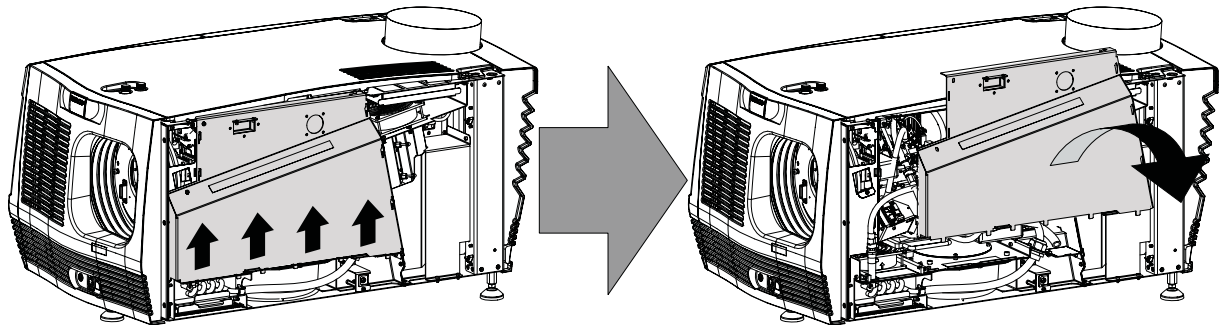

Image 5-14

5.8 Close the sealed compartment

Necessary tools

3 mm Allen wrench.

How to close the sealed compartment of the Light Processor Unit?

1. Place the cover plate in its place as illustrated.

Caution: Do not damage the micro switch at the top of the projector.

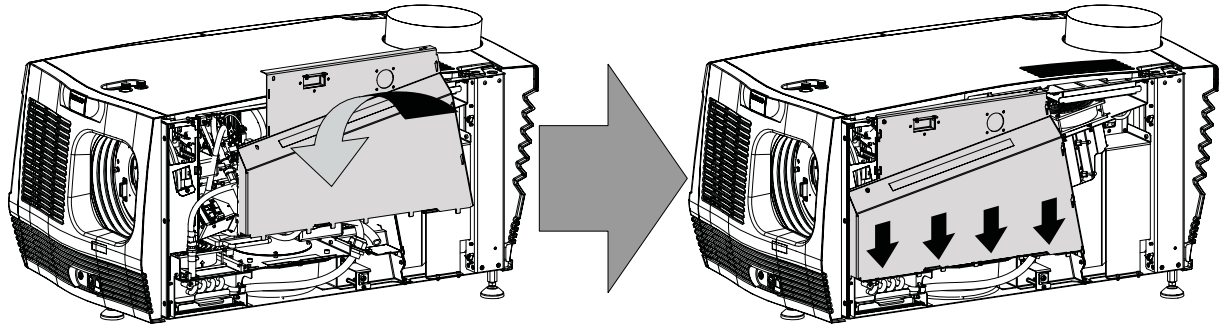

Image 5-15

2. Fasten the three hexagon head cap screws as illustrated. Use for that a 3 mm Allen wrench.

Note: Insert a washer between the each screw and the plate.

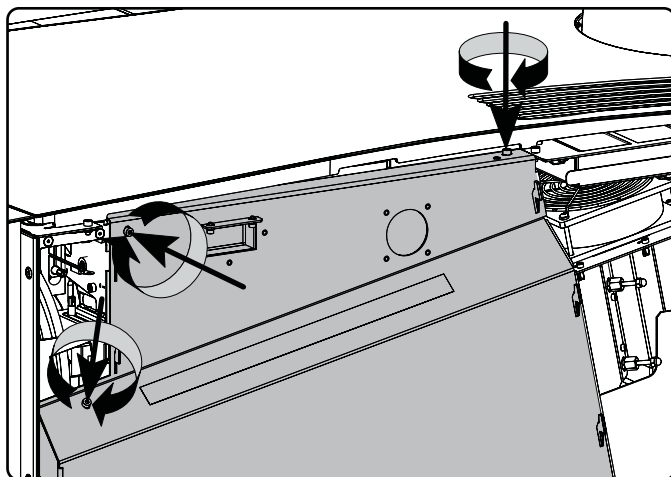

Image 5-16

5.9 Installation of the top cover

Necessary tools

Allen key 3 mm

How to install the top cover of the projector?

1. Place the top cover on the projector so that both holes matches the adjustment studs on top of the projector.

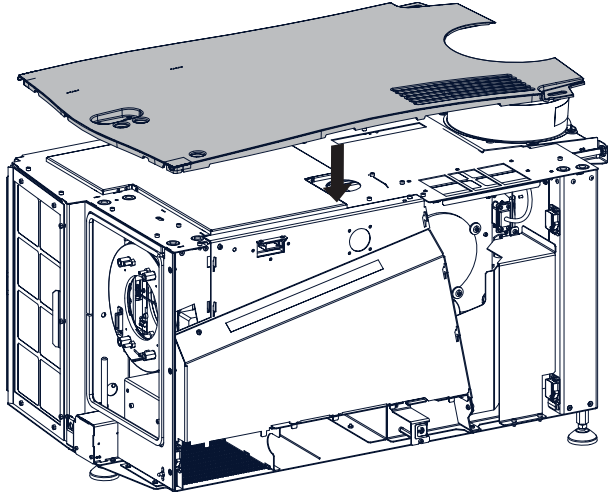

Image 5-17
Mount top cover

2. Turn all 3 fixation screws. Insert the washer between the screw and the top cover.

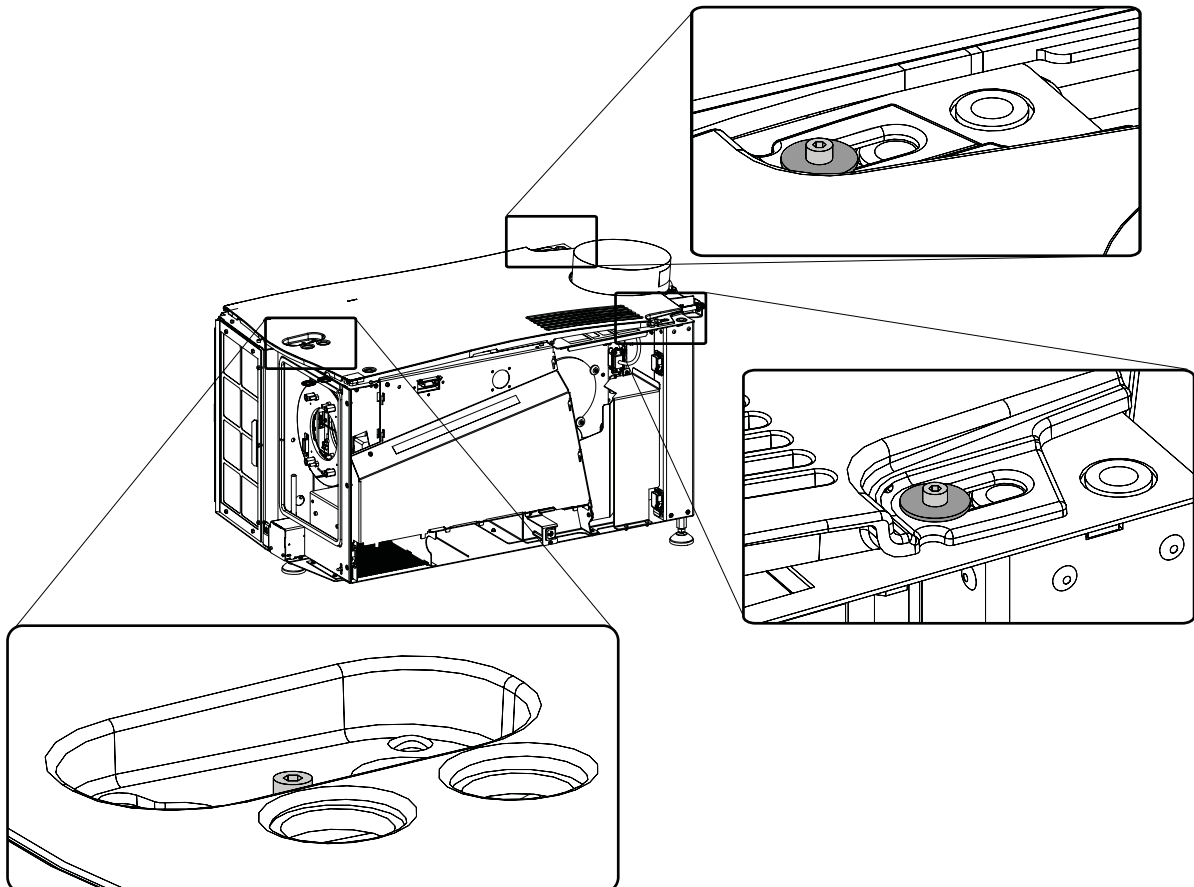

Image 5-18
Fixate top cover

5.10 Installation of the rear cover

Necessary tools

Flat screwdriver.

How to install the rear cover of the projector?

1. Install the rear cover of the projector doing the following:
 - a) Bring the rear cover towards it final position,
 - b) then gently push the locking studs of the top corners into their receivers

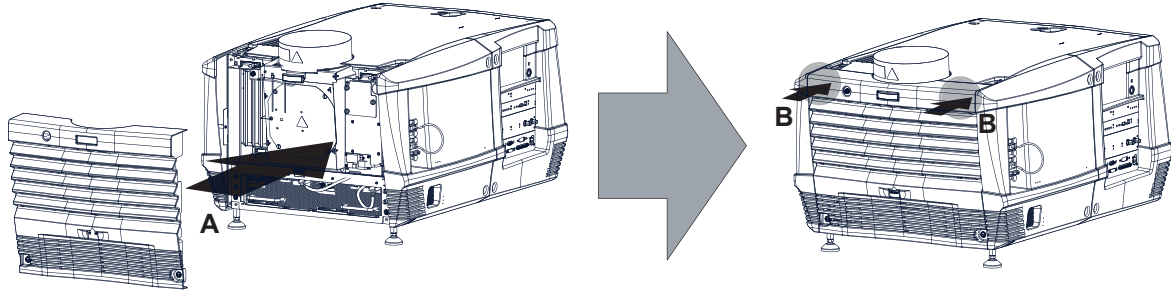

Image 5-19
Install rear housing

2. Secure the rear cover by locking the captive screws at the bottom corners of the rear cover.

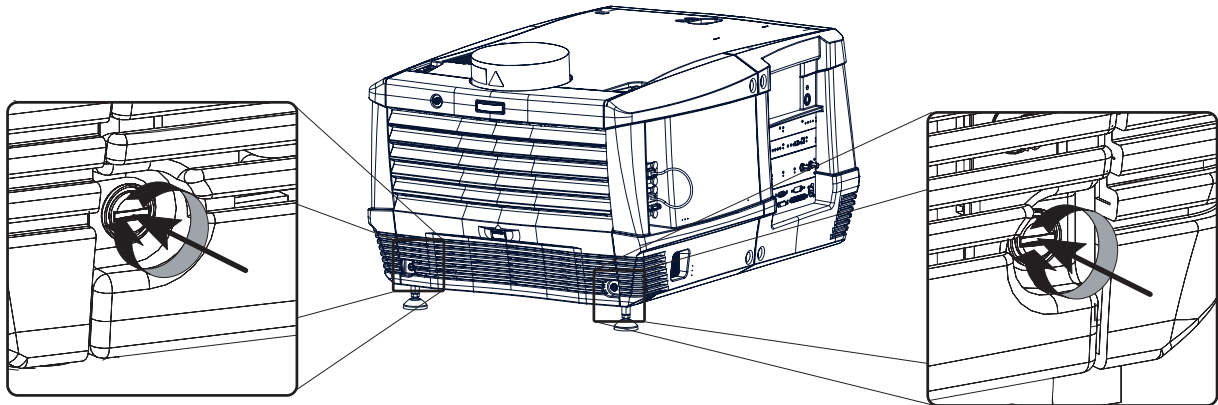

Image 5-20
Fasten rear housing

5.11 Installation of the side cover

Necessary tools

Flat screw driver.

How to install the side cover of the projector?

1. Check if the bottom and top filters are present.
2. Install the side cover of the projector doing the following:
 - a) Bring the side cover towards its final position (A),
 - b) then gently push the locking studs of the top corners (B) into their receivers,
 - c) then gently push the locking studs of the bottom corners (C) into their receivers.

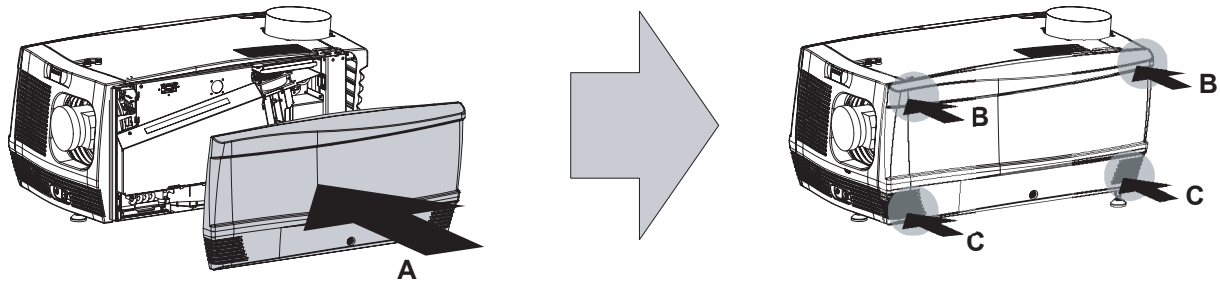

Image 5-21

3. Secure the side cover by locking the captive screw in the middle at the bottom of the side cover.

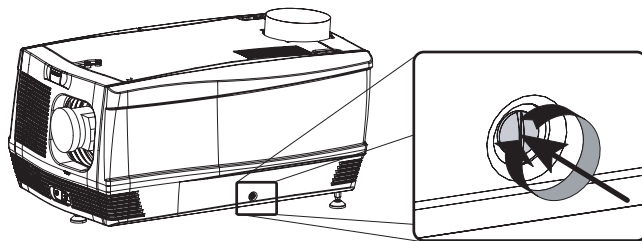

Image 5-22

5.12 Installation of the front cover



The input cover and the lens may not be installed yet.

Necessary tools

Flat screw driver.

How to install the front cover of the projector?

1. Check if the front filter is present.
2. Ensure that no lens is mounted and that the input cover is not installed.
3. Install the front cover of the projector doing the following:
 - a) first hook in the side of the front cover at the front filter,
 - b) then gently push the other side of the front cover into position,
 - c) ensure that the locking studs in the corners click into their receivers.

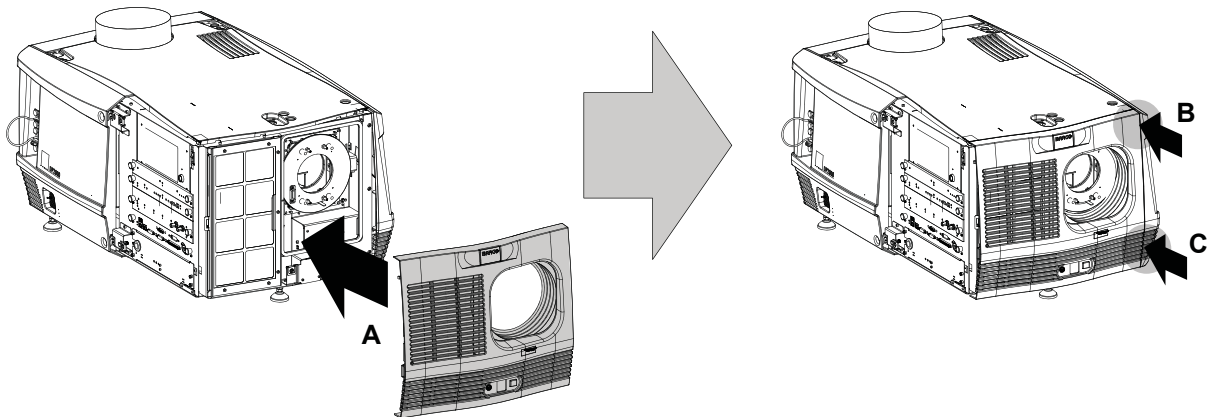

Image 5-23
Install front cover

4. Secure the front cover by locking the captive screw in the middle at the bottom of the front cover.

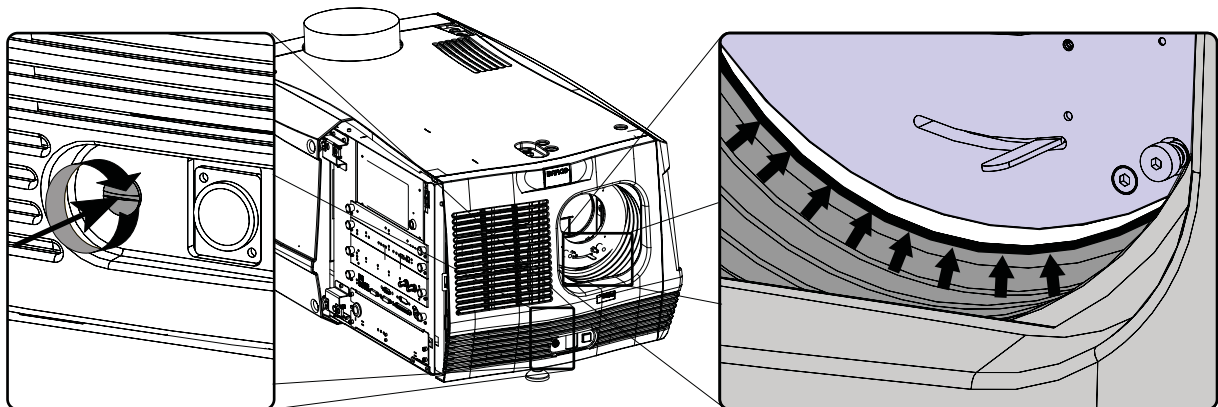

Image 5-24
Fasten front cover

5. Reinstall the rubber dust ring around the lens holder. See detail at the right of image 5-24.

5.13 Installation of the input cover

Necessary tools

Flat screw driver.

How to install the input cover of the projector?

1. Install the input cover of the projector doing the following:
 - a) Bring the input cover towards its final position (A),
 - b) then gently push the locking stud at the right top corner (B) into its receiver,
 - c) then gently push the locking stud at the right bottom corner (C) into its receiver.

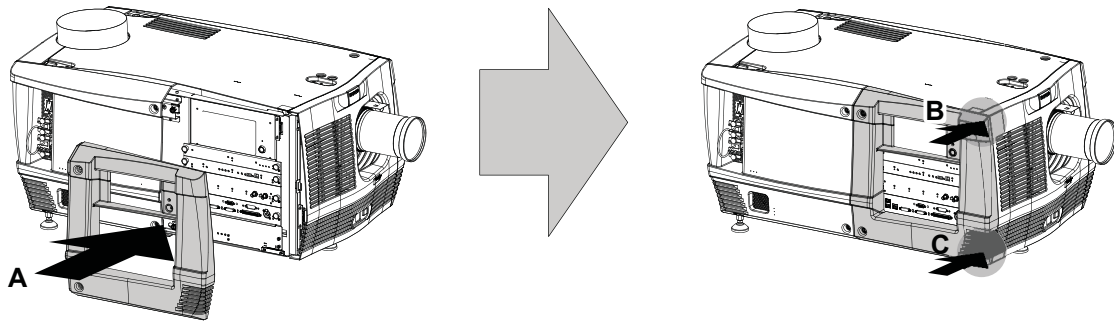

Image 5-25
Install input cover

2. Secure the input cover by locking the two captive screws at the left side of the input cover.

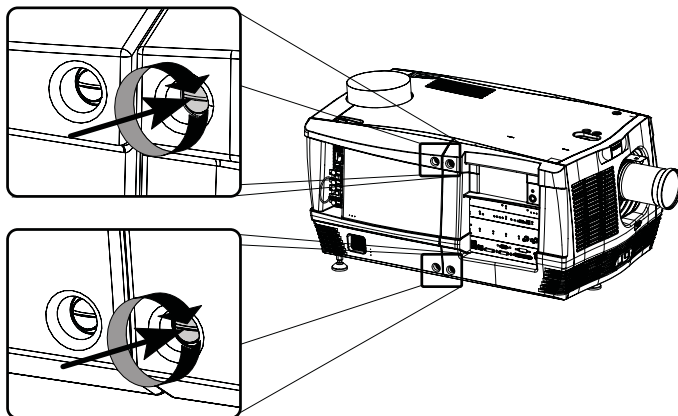

Image 5-26
Fasten input cover

6. LAMPS AND LAMP HOUSES

About this chapter

This chapter enumerates all the supported xenon lamps for the DP2K-12C/11CX and how to replace the xenon lamp in the lamp house. Also included is the procedure to reset the lamp parameters, which is required after a xenon lamp replacement, and the procedure to realign the lamp in its reflector for optimal performance.



WARNING: DO NOT PERMIT UNAUTHORIZED PERSONNEL TO PERFORM OR ATTEMPT ANY PHASE OF XENON LAMP HANDLING OR SERVICE. ONLY TRAINED AND QUALIFIED TECHNICAL SERVICE PERSONNEL ARE ALLOWED TO HANDLE THE XENON LAMP.



CAUTION: Xenon compact arc lamps are highly pressurized. When ignited, the normal operating temperature of the bulb increases the pressure to a level at which the bulb may explode if not handled in strict accordance to the manufacturer's instructions. The bulb is stable at room temperature, but may still explode if dropped or otherwise mishandled. Whenever the lamp house, containing a xenon lamp, has to be dismantled or whenever the protective container or cloth has to be removed from the xenon lamp, authorized protective clothing **MUST be worn!**



WARNING: Always wear face protection (full face shield) when handling xenon lamps.



WARNING: Always wear protective clothing (welder's jacket) when handling xenon lamps.



WARNING: Always wear clean leather gloves with wrist protectors when handling xenon lamps.

Overview

- Introduction
- Removal of the lamp house
- Removal of the xenon lamp
- Installation of the Xenon lamp
- Installation of the lamp house
- Resetting the lamp parameters
- Realignment of the lamp in its reflector
- Replacement of the Lamp Info module
- Replacement of the UV blocker
- Replacement of the lamp reflector
- Cleaning the Reflector of the Lamp House
- Cleaning the UV blocker of the Lamp House

6.1 Introduction

Lamp & lamp house

Normally the lamp house of the DP2K-12C/11CX projector is delivered with a mounted 2000 watt lamp. In case the xenon lamp is delivered separately the lamp has to be installed on site by a qualified service technician.

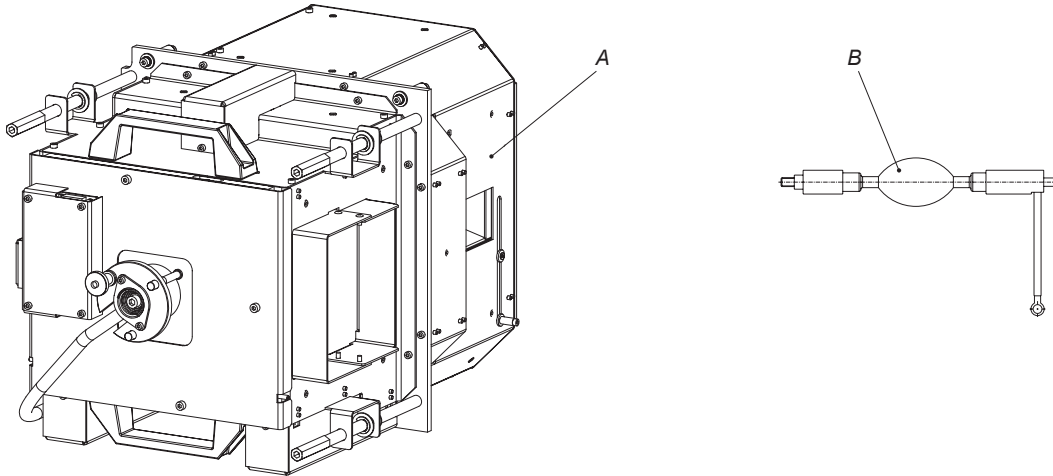

Image 6-1
A Lamp house.
B Xenon lamp.

The xenon lamp is packed in a protective container or wrapped in a protective cloth. Never remove this protective container or protective cloth without wearing adequate protective clothing (face shield, clean leather gloves, welder's jacket).



Image 6-2
Left: Xenon lamp in protective container. Right: Xenon lamp wrapped in protective cloth.



CAUTION: Xenon compact arc lamps are highly pressurized. When ignited, the normal operating temperature of the bulb increases the pressure to a level at which the bulb may explode if not handled in strict accordance to the manufacturer's instructions. The bulb is stable at room temperature, but may still explode if dropped or otherwise mishandled. Whenever the lamp house, containing a xenon lamp, has to be dismantled or whenever the protective container or cloth has to be removed from the xenon lamp, authorized protective clothing MUST be worn!

Cathode adaptor

A cathode adaptor is required to mount the xenon lamp in the lamp house. The cathode adaptor has to be mounted upon the cathode side of the xenon lamp prior to mounting the lamp in the lamp house. The purpose of the cathode adaptor is to position the arc of the xenon lamp in the middle of the reflector inside the lamp house.

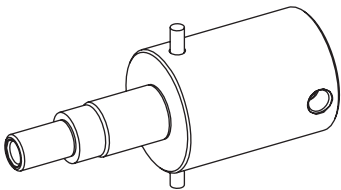

Image 6-3
Cathode adaptor (R858100K)

Supported xenon bulb lamps (without lamp house)

| Lamp | Type | Order info | |
|--------------------------|---------|------------|--|
| Osram xenon lamp of 2 kW | 2kW DHP | R9855956 | |

| Lamp | Type | Order info | |
|---------------------------|------------|------------|--|
| Osram xenon lamp of 1.2kW | 1200W DHP | R9855959 | |
| Ushio xenon lamp of 2 kW | DXL20BAF | R9855955 | |
| Ushio xenon lamp of 2 kW | DXL20BAF/2 | R9855965 | |
| Ushio xenon lamp of 1.2kW | DXL12BAF | R9855961 | |

6.2 Removal of the lamp house



WARNING: This procedure may only be performed by qualified technical service personnel.



CAUTION: Lamp casing is very hot after operation. To avoid burns, let the projector cool down for at least 15 minutes before proceeding to the lamp unit replacement.



CAUTION: Due to its high internal pressure, the lamp may explode in either hot or cold states if improperly handled.

Necessary tools

- Flat screw driver or
- Nut driver 8 mm

How to remove the lamp house of the projector

1. Switch off the projector.
2. Remove the lamp cover.
3. Release the three spring lock screws of the lamp house as illustrated.

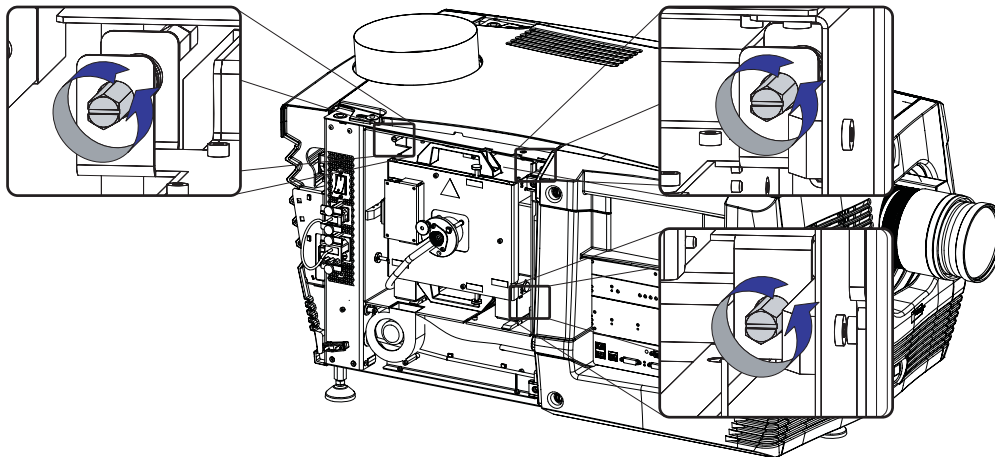

Image 6-4
Release lamp house

4. Take the lamp house by the handles and pull it out of the projector.

Caution: Be aware of the weight of the lamp assembly. Take the necessary precautions to avoid personal injury.

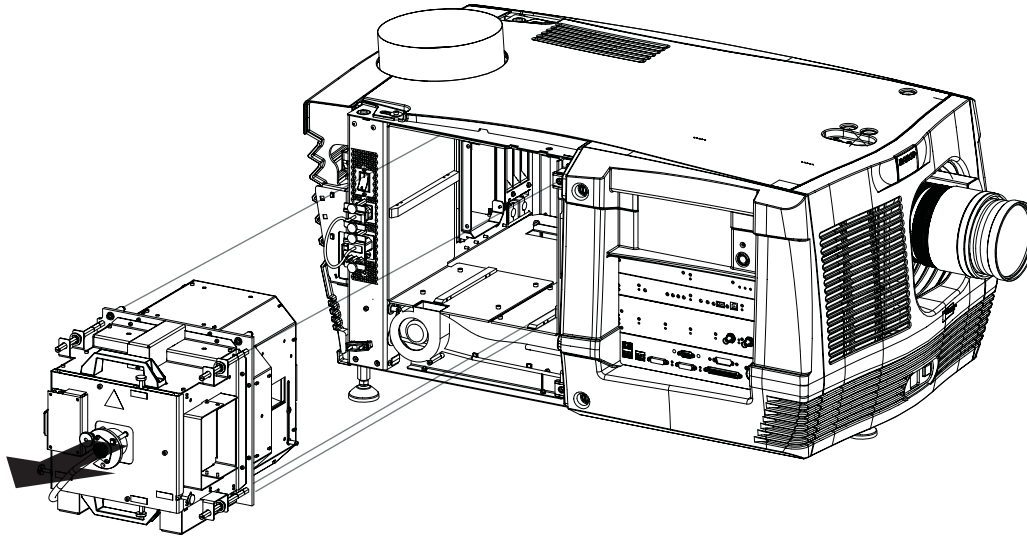

Image 6-5
Remove lamp house

5. Place the lamp house on a stable support.



While starting up the projector, the electronics detect if a lamp is installed. If no lamp is installed, it is not possible to start up the projector.

6.3 Removal of the xenon lamp



WARNING: DO NOT PERMIT UNAUTHORIZED PERSONNEL TO PERFORM OR ATTEMPT ANY PHASE OF XENON LAMP HANDLING OR SERVICE. ONLY TRAINED AND QUALIFIED TECHNICAL SERVICE PERSONNEL ARE ALLOWED TO HANDLE THE XENON LAMP.



WARNING: This procedure may only be performed by qualified technical service personnel.



CAUTION: Xenon compact arc lamps are highly pressurized. When ignited, the normal operating temperature of the bulb increases the pressure to a level at which the bulb may explode if not handled in strict accordance to the manufacturer's instructions. The bulb is stable at room temperature, but may still explode if dropped or otherwise mishandled. Whenever the lamp house, containing a xenon lamp, has to be dismantled or whenever the protective container or cloth has to be removed from the xenon lamp, authorized protective clothing **MUST be worn!**



WARNING: Always wear face protection (full face shield) when handling xenon lamps.



WARNING: Always wear protective clothing (welder's jacket) when handling xenon lamps.



WARNING: Always wear clean leather gloves with wrist protectors when handling xenon lamps.

Necessary tools

- Flat blade screw driver.
- 5 mm Allen wrench.
- 17 mm open-end wrench (2 pieces).
- Lamp protective container or protective cloth with two binders.

How to remove the xenon lamp from the lamp house?

1. Release the xenon lamp from its socket by removing the hexagon socket head cap screw and washer as illustrated. Use a 5 mm Allen wrench.

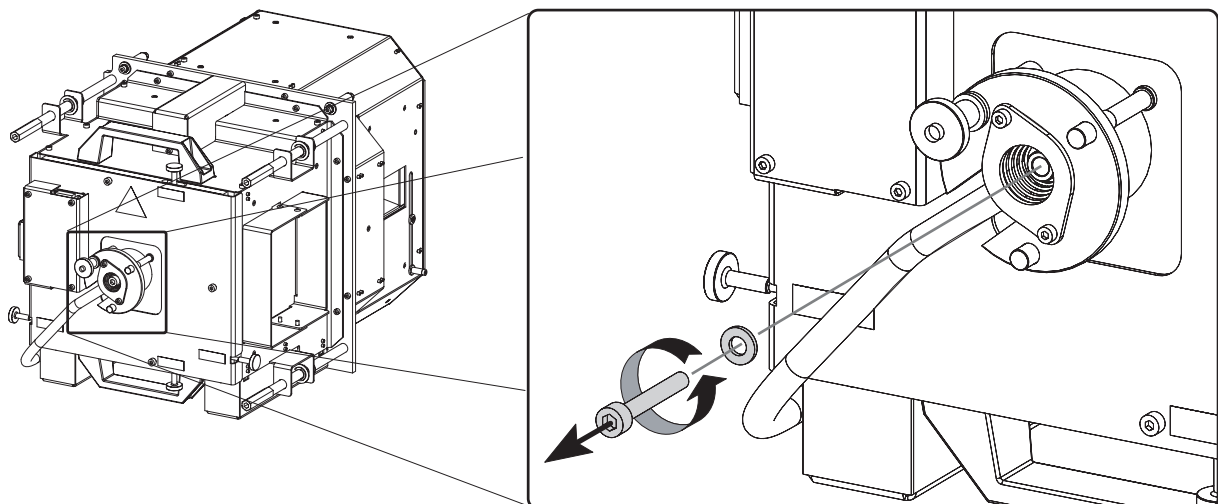

Image 6-6

2. Remove the Lamp House side cover by releasing the two retaining thumbscrews as illustrated.

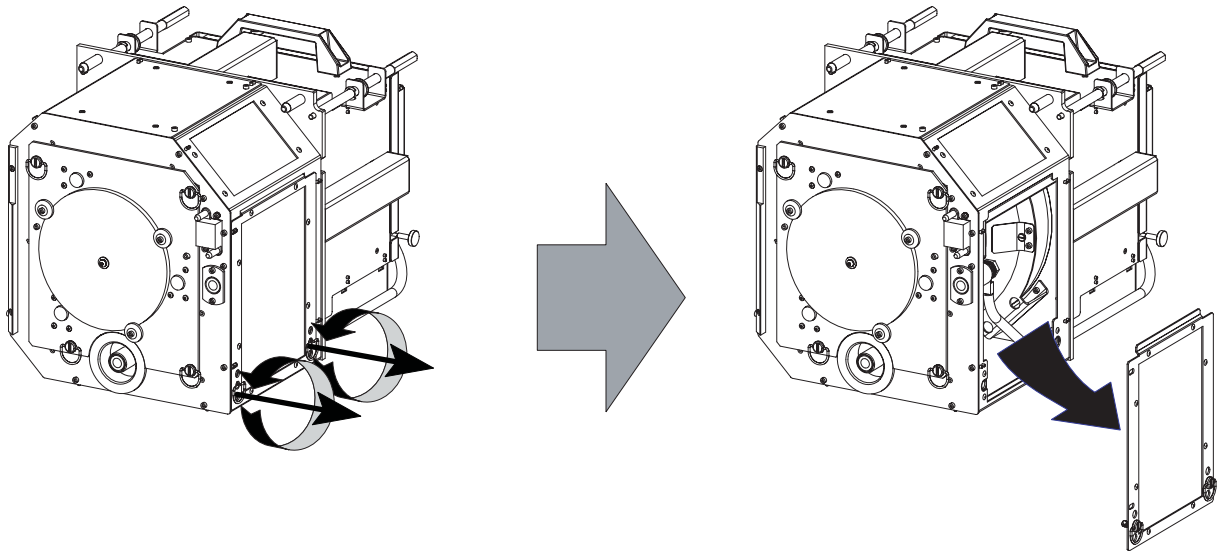

Image 6-7

3. Release the four retaining thumbscrews of the UV blocker assembly as illustrated. Make sure that the UV blocker assembly remains in its position while releasing the screws.

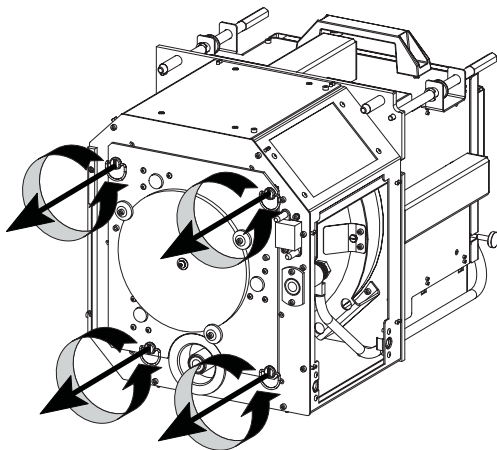

Image 6-8

4. Support the xenon lamp inside the Lamp House with one hand while removing the UV blocker assembly from the Lamp House. Note that some xenon lamps are installed with an anode adaptation bushing.
Caution: Ensure that you wear protective clothing, a full face shield and protective gloves.

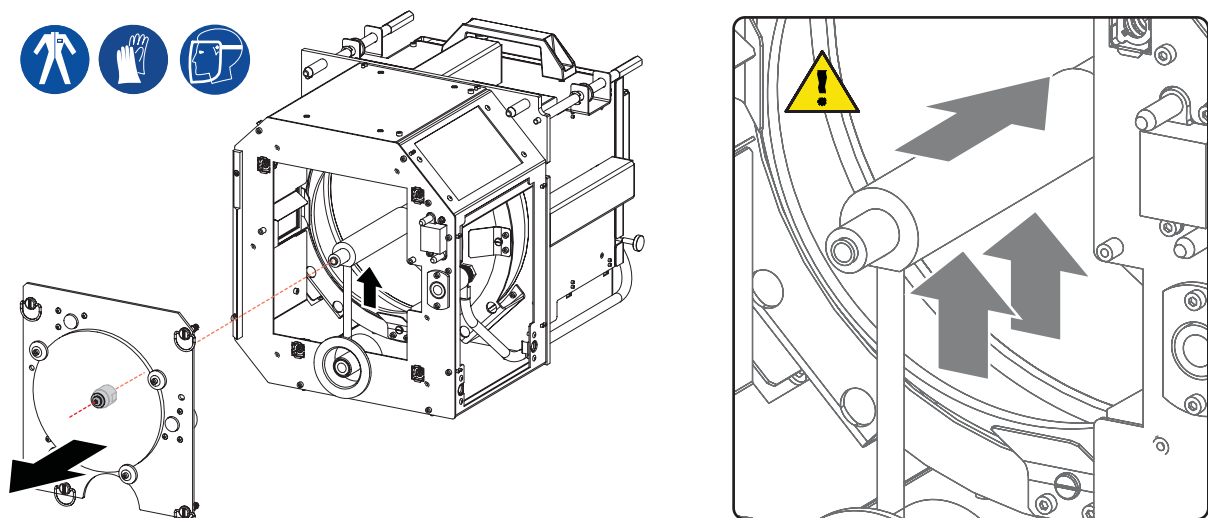

Image 6-9

5. Slide the white anode socket, which is connected via a thick wire with the xenon lamp, upwards away from its position and then remove the xenon lamp with anode socket from the Lamp House.

6. Lamps and lamp houses

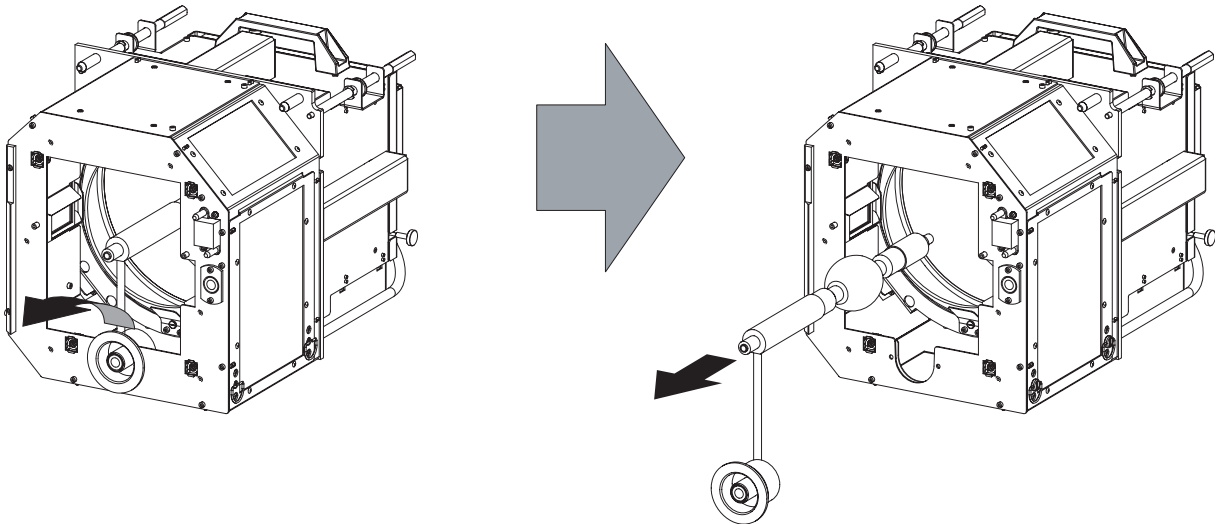

Image 6-10

- Place the xenon lamp into a protective container or wrap a protective cloth around the xenon lamp prior to proceed with this procedure.
- Remove the anode wire lug from the anode socket. Use for that two open end wrenches of 17 mm. Hold one nut (reference 7) with one wrench while releasing the other nut (reference 4) with the other wrench. Note that a plain washer (reference 5) is provided between the lock nut (reference 4) and the anode wire lug (reference 6).

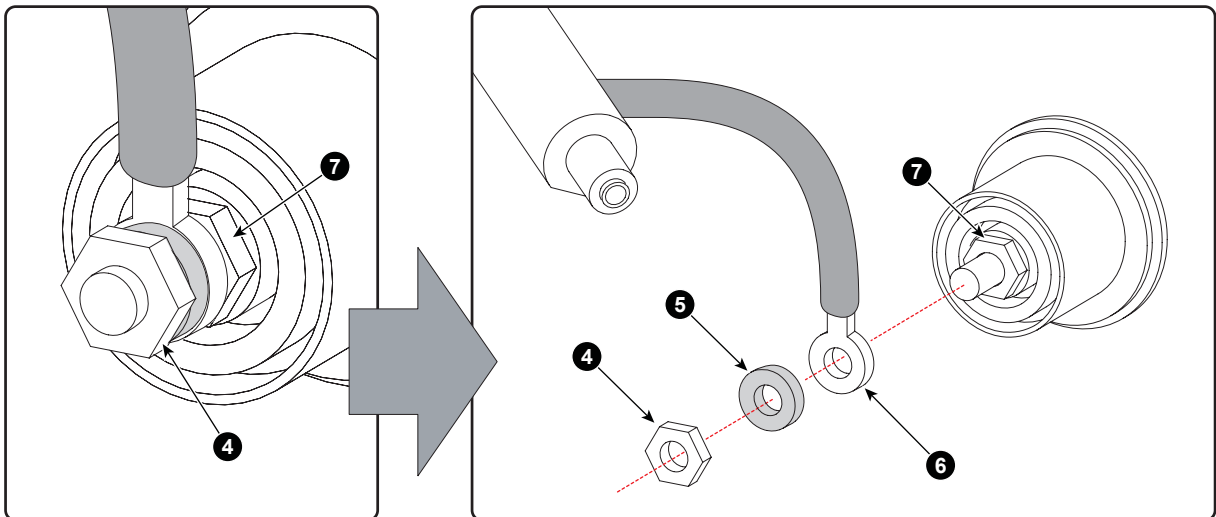

Image 6-11

Note: The electrical connection pins of older Lamp Houses may contain two flat washers, one on each side of the wire lug. New Lamp Houses can contain only one flat washer due to the shorter thread clearance of the new improved connection pins.

- Remove the cathode lamp adaptor (reference 11) from the xenon lamp (reference 13) as illustrated. Use a 5 mm Allen wrench to release the adaptor fixation screw (reference 12) of the adaptor.

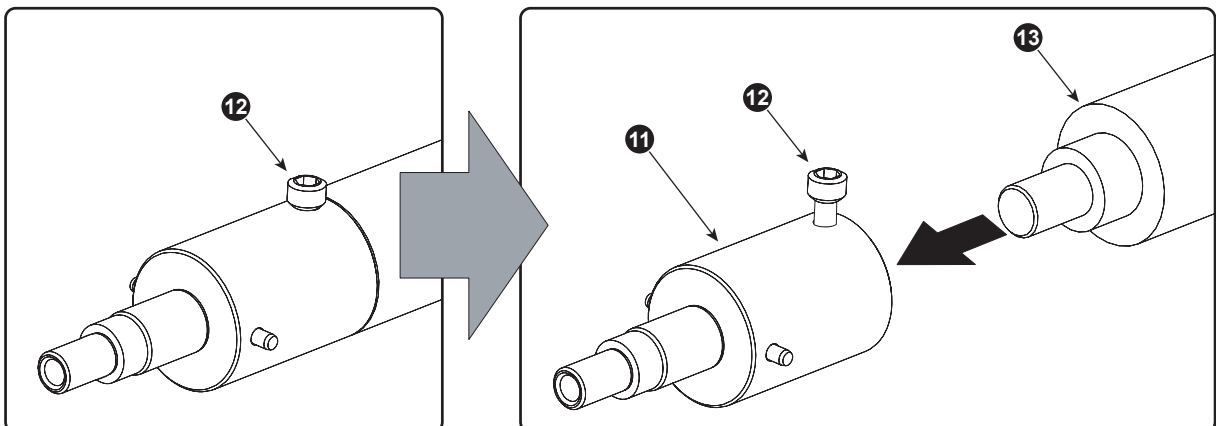

Image 6-12



CAUTION: Expired xenon lamps.

Dispose of expired bulbs that are beyond warranty in the following manner: wrap the bulb tightly in several layers of canvas or heavy cloth. Place it on hard surface and shatter the envelope with a sharp hammer blow. **DO NOT** place a non shattered bulb in any ordinary refuse container.



CAUTION: Small amounts of radioactive material (< 1000 Bq per lamp) are deliberately added to Xenon lamps for functional reasons. These lamps are manufactured under regulatory control as consumer product according to IAEA basic safety standard BSS 115. Disposal according to national regulations is required e.g. in Europe covered by WEEE regulation. See also related user manual of the lamp supplier for more guidance.



When returning a xenon lamp for warranty adjustment, pack it in its original shipping container. Complete and return all required warranty information.

6.4 Installation of the Xenon lamp



WARNING: DO NOT PERMIT UNAUTHORIZED PERSONNEL TO PERFORM OR ATTEMPT ANY PHASE OF XENON LAMP HANDLING OR SERVICE. ONLY TRAINED AND QUALIFIED TECHNICAL SERVICE PERSONNEL ARE ALLOWED TO HANDLE THE XENON LAMP.



WARNING: This procedure may only be performed by qualified technical service personnel.



CAUTION: Xenon compact arc lamps are highly pressurized. When ignited, the normal operating temperature of the bulb increases the pressure to a level at which the bulb may explode if not handled in strict accordance to the manufacturer's instructions. The bulb is stable at room temperature, but may still explode if dropped or otherwise mishandled. Whenever the lamp house, containing a xenon lamp, has to be dismantled or whenever the protective container or cloth has to be removed from the xenon lamp, authorized protective clothing **MUST be worn!**



WARNING: Always wear face protection (full face shield) when handling xenon lamps.



WARNING: Always wear protective clothing (welder's jacket) when handling xenon lamps.



WARNING: Always wear clean leather gloves with wrist protectors when handling xenon lamps.

Necessary tools

- 17 mm open ended wrench.
- Torque wrench with 17 mm hexagon socket
- Torque wrench with 5 mm Allen socket.

Necessary parts

- Lamp cathode adapter.
- Hexagon socket head screw M6 x 40.
- Flat washer.

How to install the xenon lamp into the lamp house

1. Remove the UV blocker and side cover of the lamp house by releasing the retaining thumbscrews as illustrated.
Note: In case of a lamp replacement, the UV blocker will be already removed.

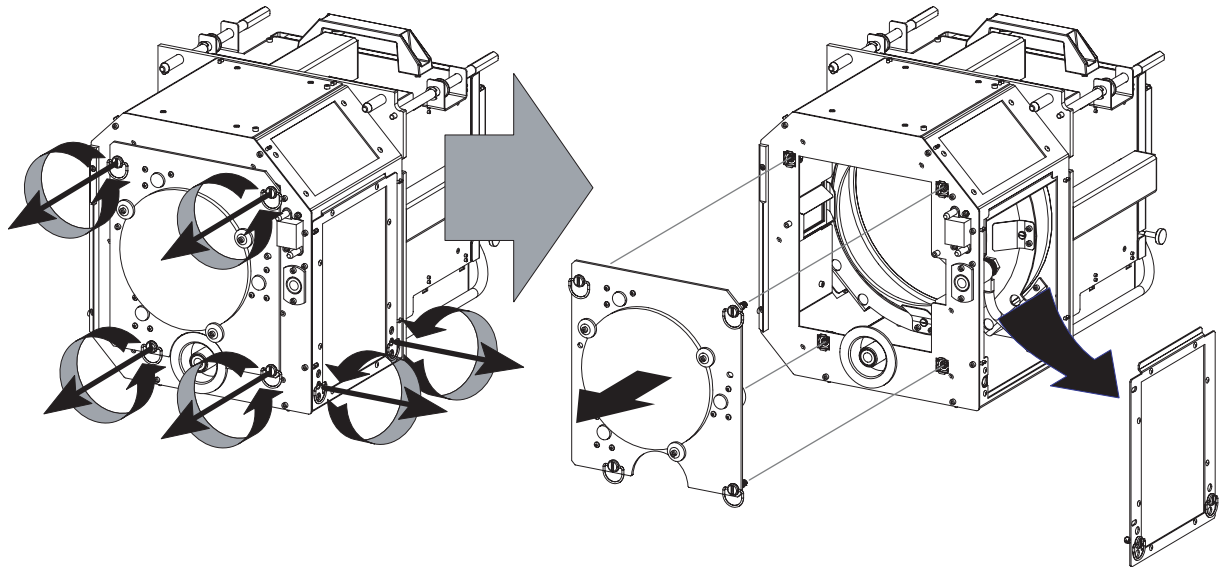

Image 6-13
Remove UV blocker and side cover

2. Install the lamp cathode adaptor (reference 1) upon the xenon lamp (reference 3) as illustrated. Tighten the adaptor fixation screw (reference 2) with a torque of **2,5 Nm** (1.84 lbf*ft). Use for that a torque wrench with a 5 mm Allen socket. Make sure that there is full contact between the cathode adaptor and the lamp base.

Note: Do not take the lamp out of its protective container or protective cloth while mounting the adaptor.

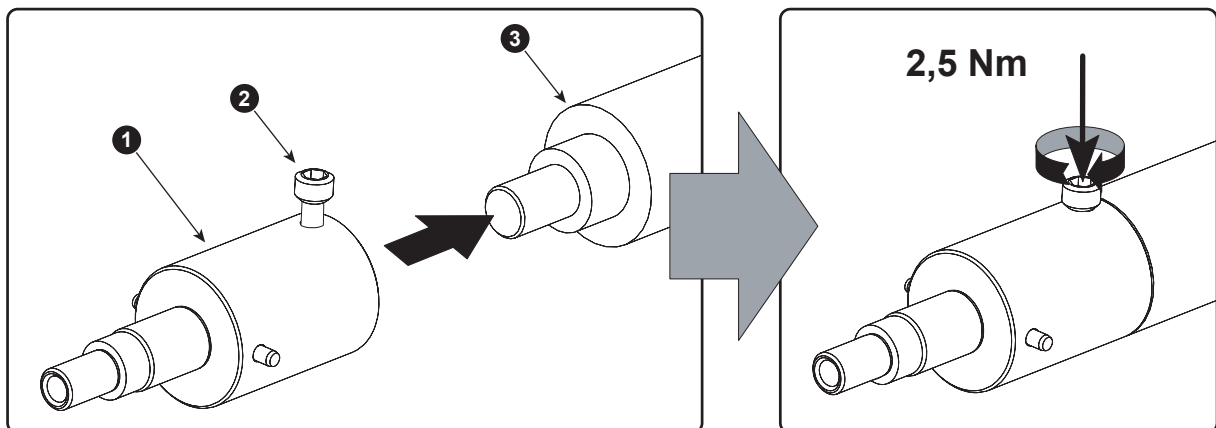

Image 6-14
Mount cathode adaptor

3. Install the anode wire lug (reference 6) upon the anode socket. Use an 17 mm open-end wrench to hold the first nut (reference 7) while fastening the lock nut (reference 4) on the rod with a torque of **9 Nm** (6,64 lbf*ft) using a torque wrench with 17 mm hexagon socket. Ensure that there is a flat washer (reference 5) between the lock nut and the wire lug.

Caution: Do not tighten the first nut (reference 1) against the connector housing. There must be some play (1 mm maximum). This is important to insert the Lamp House smoothly into the projector.

6. Lamps and lamp houses

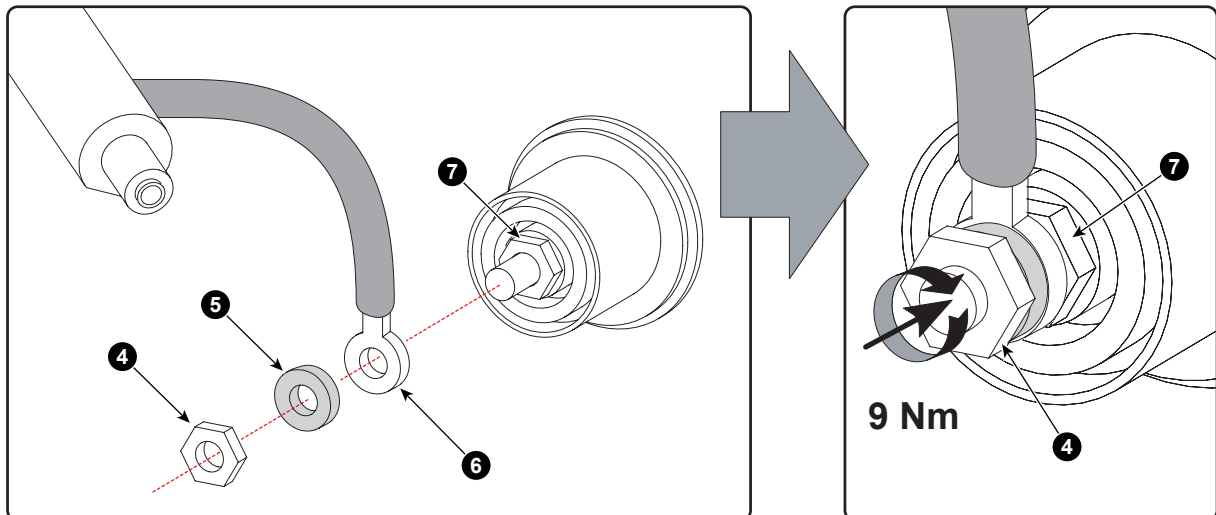

Image 6-15
Anode lug installation

4. Remove the protective container or unwrap the protective cloth from the xenon lamp.
Warning: Ensure that you wear protective clothing, a full face shield and protective gloves.
Tip: Write down the serial number of the lamp. You will need this while updating the lamp parameters after installation of the lamp. The serial number of the lamp is engraved in the neck of the xenon lamp.
5. Gently guide the xenon lamp into position inside the Lamp House as illustrated. Anode socket hanging vertical down. While inserting the lamp, rotate it slightly, engaging the pins of the cathode adapter in the foreseen slots. This is to ensure the lamp cathode is completely inserted.

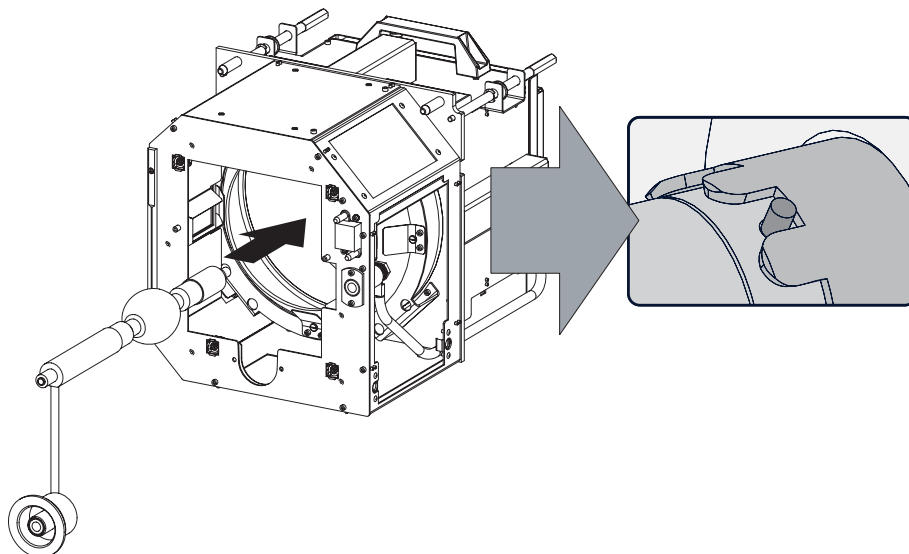

Image 6-16
Lamp bulb installation

Warning: Make sure that the both pins of the cathode adapter are engaged in the foreseen slots.

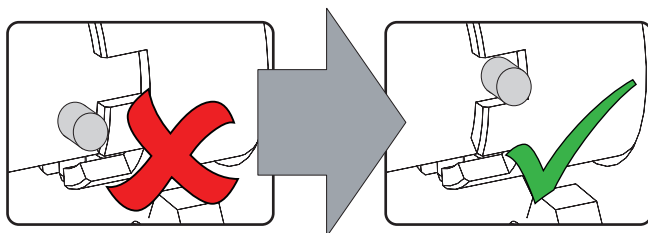

Image 6-17

6. Insert the anode socket into position as illustrated.
Caution: Avoid any tension on the anode wire, ensuring there is no mechanical stress on the lamp.

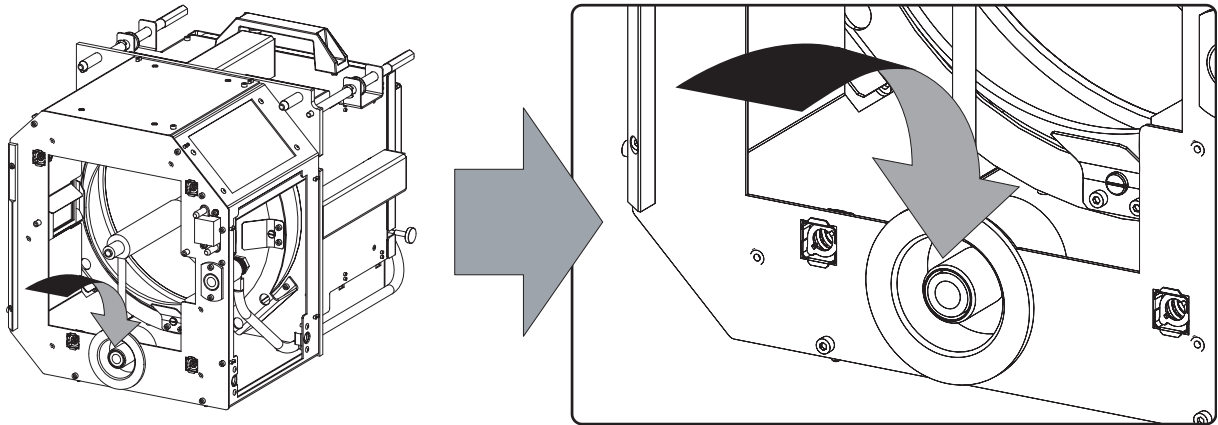

Image 6-18
Anode socket installation

7. Reinstall the UV blocker assembly as illustrated. Make sure that the xenon lamp is properly supported by the lamp supporting mechanism in the centre of the UV blocker. Use the opening at the side of the Lamp House to guide the supporting pin of the xenon lamp into the anode supporting mechanism.

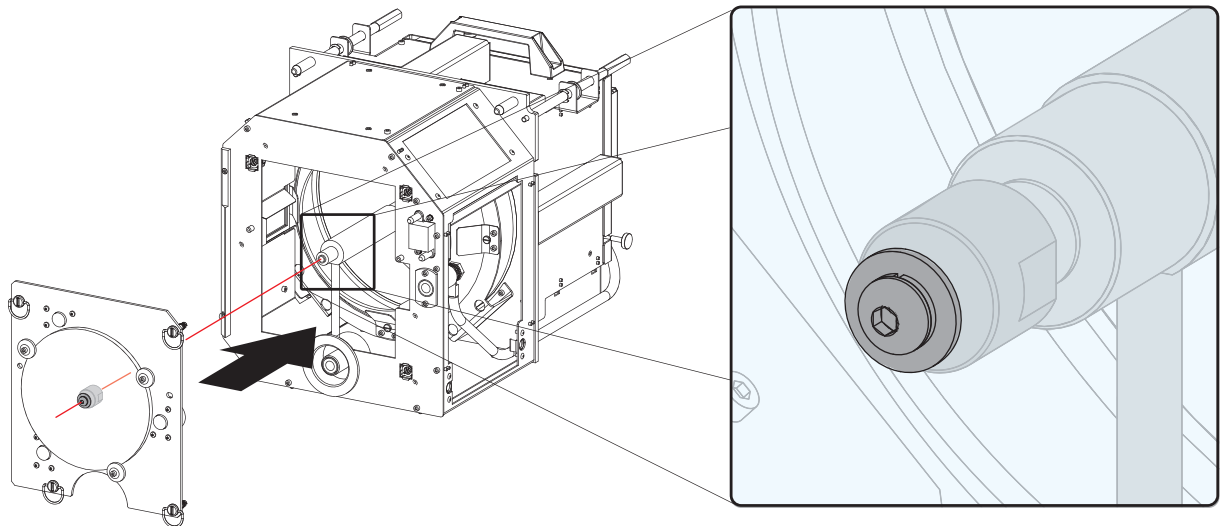

Image 6-19
UV blocker installation

8. Secure the UV blocker by fastening the four retaining thumbscrews as illustrated.

Note: Please ensure that the thumb screws turning wires are flush with the cover or interference will occur while inserting the lamp house into the projector.

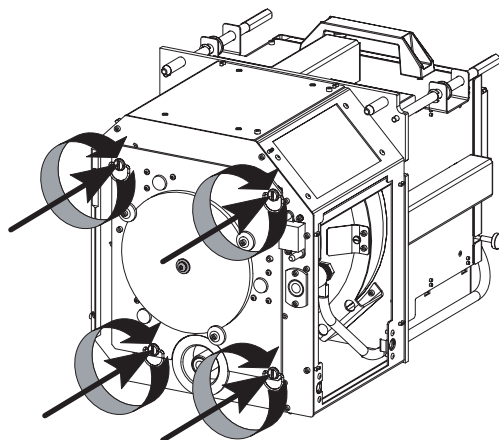

Image 6-20
Secure UV blocker

9. Fasten the cathode side of the xenon lamp using a hexagon socket head screw M6 x 40 and a plain washer as illustrated. Use a torque of **2,5 Nm** (1,84 lb*ft) to fasten the hexagon socket head screw. Use for that a torque wrench with a 5 mm Allen socket.
Caution: Make sure that the both pins of the cathode adapter remain engaged in the foreseen slots. Use one hand to keep the xenon lamp into position while inserting the hexagon socket head screw.

6. Lamps and lamp houses

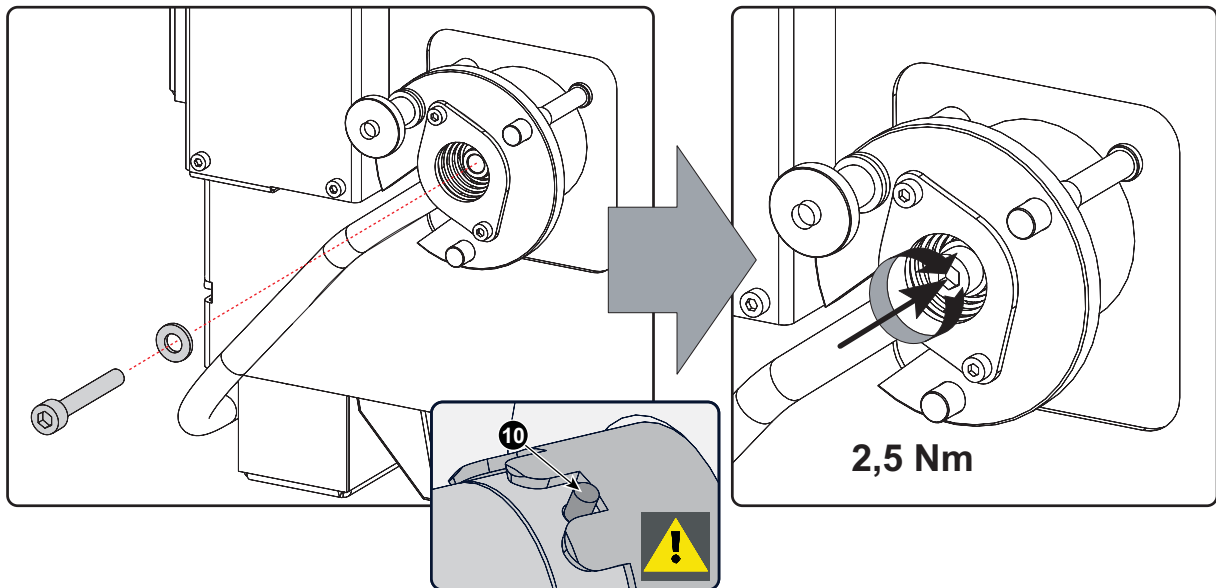

Image 6-21
Fasten cathode side

10. Check the cathode connection inside the Lamp House. Use a 17 mm open-end wrench to hold the first nut while fastening the second nut on the rod with a torque of **9 Nm** (6,64 lb*ft) using a torque wrench with 17 mm hexagon socket. Ensure that there is a flat washer (reference 3) between the lock nut and the wire lug.

Caution: This cathode connection must be checked with every lamp change!

Caution: Do not tighten the first nut (reference 1) against the connector housing. There must be some play (1 mm maximum). This is important to insert the Lamp House smoothly into the projector.

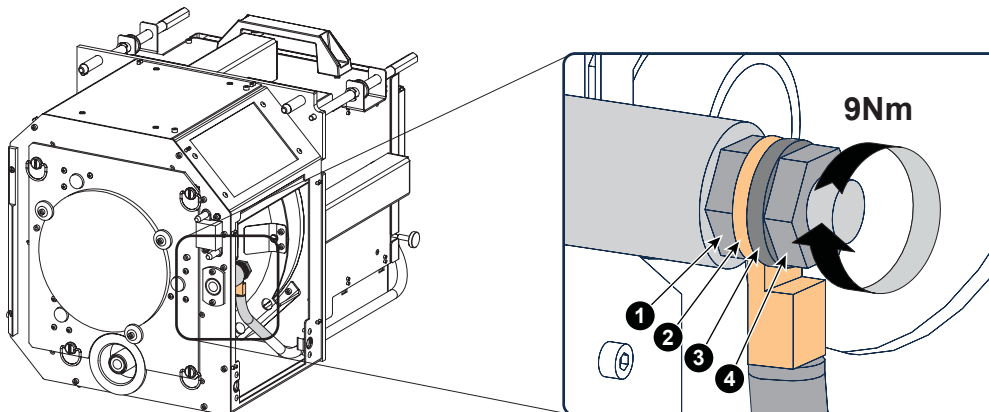

Image 6-22
Check cathode connection

Note: The electrical connection pins of older Lamp Houses may contain two flat washers, one on each side of the wire lug. New Lamp Houses can contain only one flat washer due to the shorter thread clearance of the new improved connection pins.

11. Reinstall the side cover of the Lamp House as illustrated.

Note: Please ensure that the thumb screws turning wires are flush with the cover or interference will occur while inserting the Lamp House into the projector.

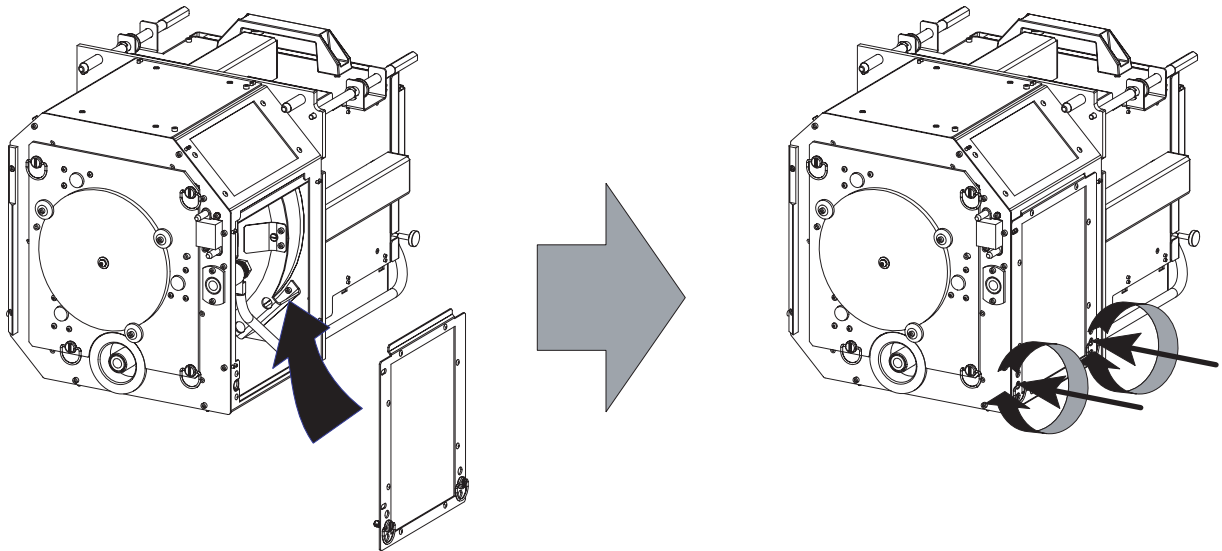

Image 6-23
Close side cover



CAUTION: The “LAMP INFO” parameters **MUST** be updated after each installation of a xenon lamp inside the lamp house. Neglecting this update will result in poor performance and short life time of the xenon lamp. See procedure “Resetting the lamp parameters”.



A realignment of the xenon lamp in its reflector is required after the installation of the xenon lamp in the lamp house. See procedure “Realignment of the lamp in its reflector”, page 111.

6.5 Installation of the lamp house



WARNING: This procedure may only be performed by qualified technical service personnel.



CAUTION: Due to its high internal pressure, the lamp may explode in either hot or cold states if improperly handled.

Necessary tools

Flat screw driver.

How to install the lamp house

1. Ensure the projector is switched off.
2. Remove the lamp cover.
3. Hold fast the lamp house by its handles and gently slide the lamp house into its socket. Note that the compartment is provided with guides (G) to position the lamp house correctly.

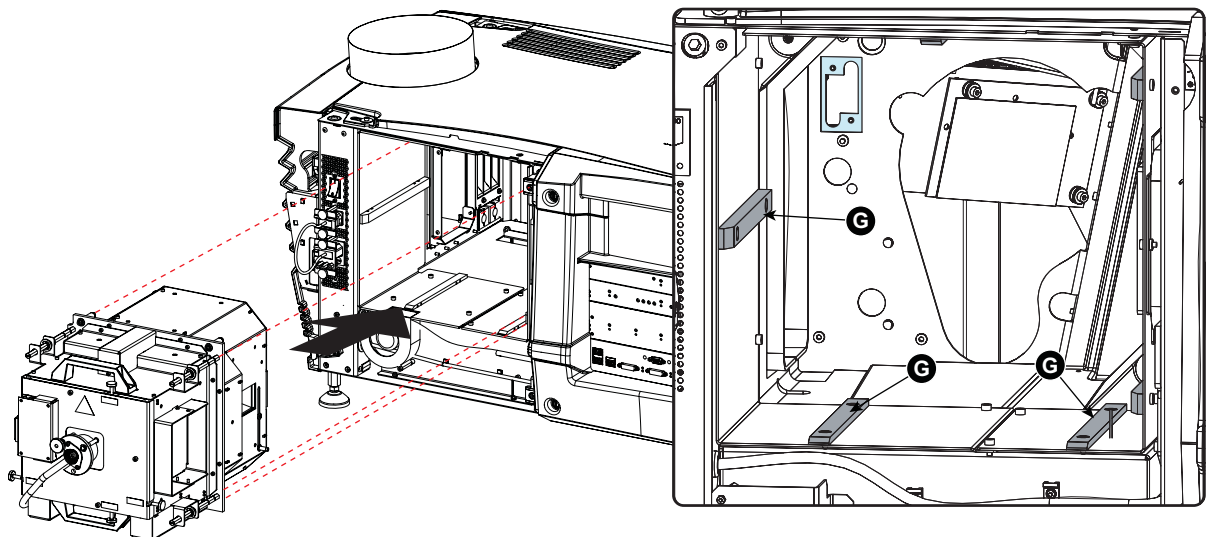

Image 6-24
Mount lamp house

4. Push the lamp house forward until it slides fully into the projector.
5. Secure the correct position of the lamp house by tightening all three spring lock screws as illustrated.

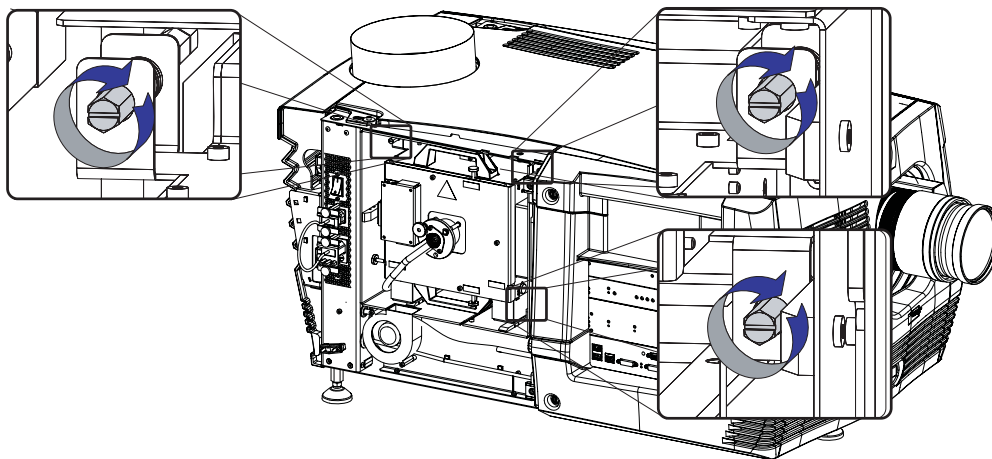

Image 6-25
Secure lamp house

6. Reinstall the lamp cover of the projector.



While starting up the projector, the electronics detect if a lamp is installed. If no lamp is installed, it is not possible to start up the projector.

6.6 Resetting the lamp parameters



CAUTION: The “LAMP INFO” parameters **MUST** be updated after each installation of a xenon lamp inside the Lamp House. Neglecting this update will result in poor performance and short life time of the xenon lamp.

How to reset the lamp parameters?

1. Start up the projector but do not ignite the lamp.
2. Go via the **Communicator** touch panel to the menu “Installation” > “Lamp” > “Lamp information”.
3. While the *Lamp information* window is displayed, tap on **Reset** (1).
A reset message is displayed (2).
4. Tap on **Select** (3) to display a list of possible article numbers (4). Select a article number (5) and tap **OK** (6).
The software will validate the selected article number (7).
5. Fill out the serial number of the lamp (8).
6. Click **Reset** (9).

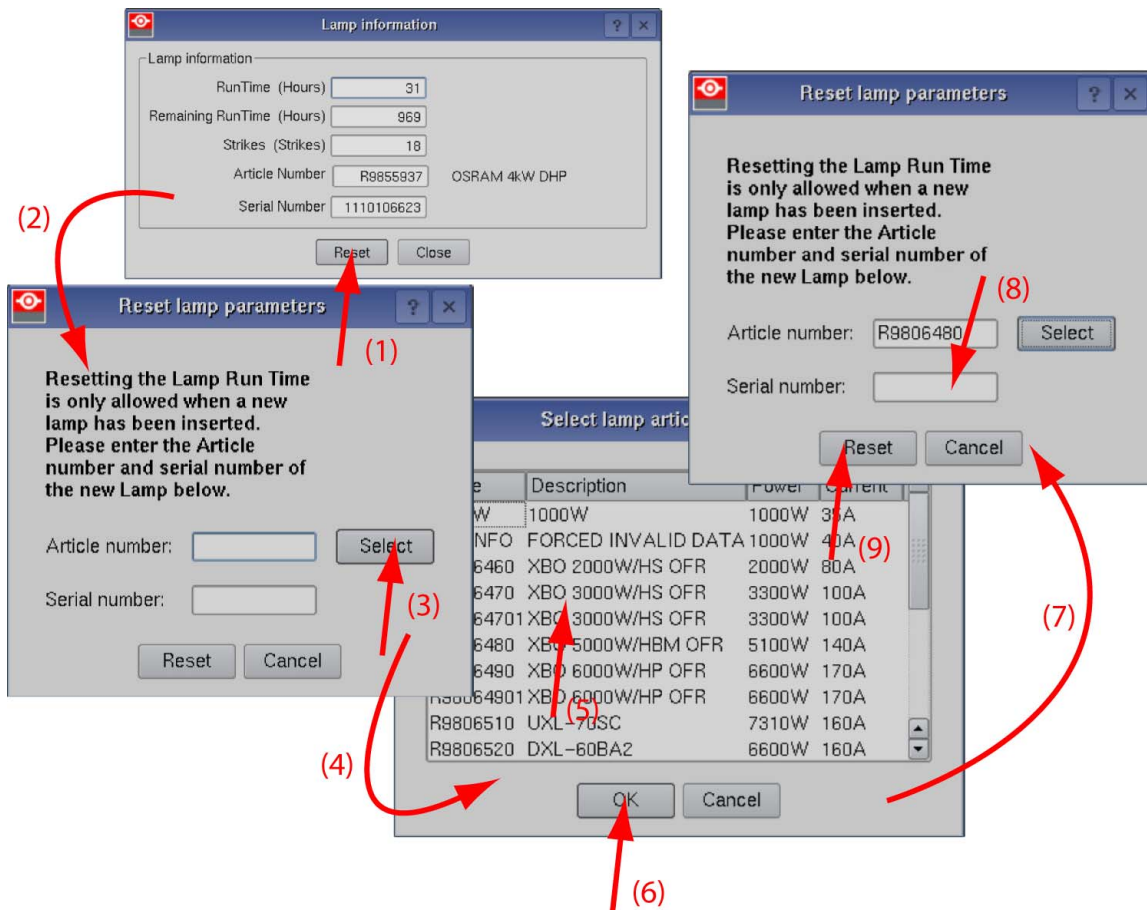

Image 6-26
Reset lamp info



CAUTION: For more information about using the Communicator Touch Panel consult the user’s guide of the Communicator Touch Panel.

6.7 Realignment of the lamp in its reflector



Each xenon lamp installation requires a realignment of the lamp in its reflector for optimal performance of the xenon lamp. Furthermore, it is recommended to realign the lamp after the first run time of 100 and 200 hours. Especially the Z-axis of the lamp.



WARNING: This procedure may only be performed by qualified technical service personnel.

How to realign the lamp in its reflector?

1. Remove the cover of the lamp compartment to gain access to the X-, Y-, and Z-axis adjustment thumbscrews of the lamp.
2. Some lamp houses may have lock nuts on the X and Y adjustment screws which are locked. Before starting the adjustment, fully turn these lock nuts against the thumbscrew.

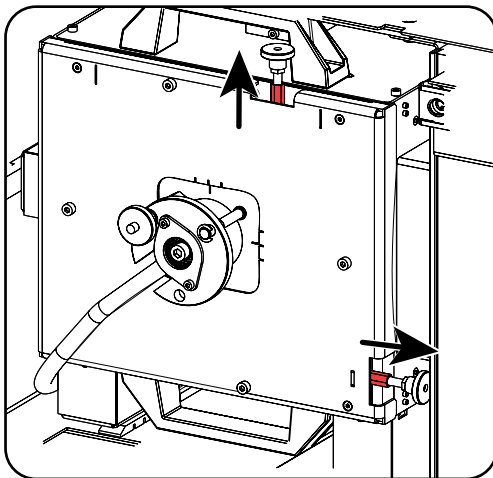

Image 6-27
Lock nuts

3. Switch on the projector and start up the lamp.
4. Go via the Communicator touch panel to the menu "Installation" > "Lamp" > "Light output".
5. Set the "Light output mode" in normal mode and the "Lamp Dimming" on maximum (255).
Note: This window on the Communicator touch panel shows in the upper left corner the measured value of the built-in light sensor of the projector.

6. Lamps and lamp houses

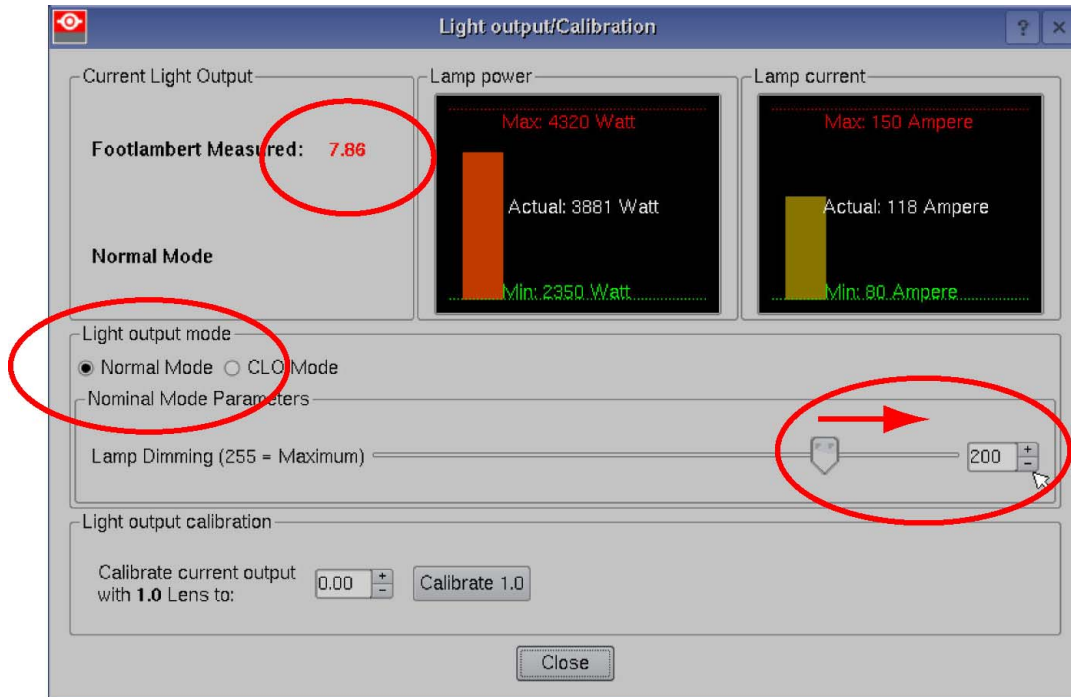

Image 6-28
Light mode selection

- Adjust the X-axis (ref X image 6-29), the Y-axis (ref Y image 6-29) and the Z-axis (ref Z image 6-29) for maximum current light output (Footlambert Measured). Carefully turn the thumbscrew for maximum light output. Once over the maximum, turn slightly in opposite direction to reach the maximum light output again. Do this for each direction and repeat this adjustment cycle twice.

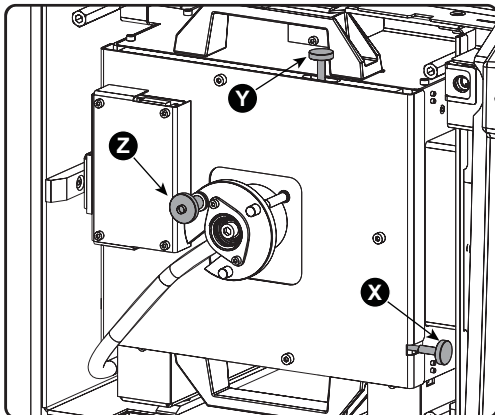

Image 6-29
Lamp adjustment

- If lock nuts are available, these nuts can be locked again.
- Switch off the projector.
- Reinstall the cover of the lamp compartment.

6.8 Replacement of the Lamp Info module



This procedure requires that the lamp house is removed from the projector. See procedure "Removal of the lamp house", page 96.

Necessary tools

- 2,5 mm Allen wrench.
- 5 mm nut driver.

How to replace the Lamp Info module?

1. Remove the cover of the Lamp Info module by releasing the hexagon socket head cap screws (reference 1) as illustrated. Use a 2,5 mm Allen wrench.

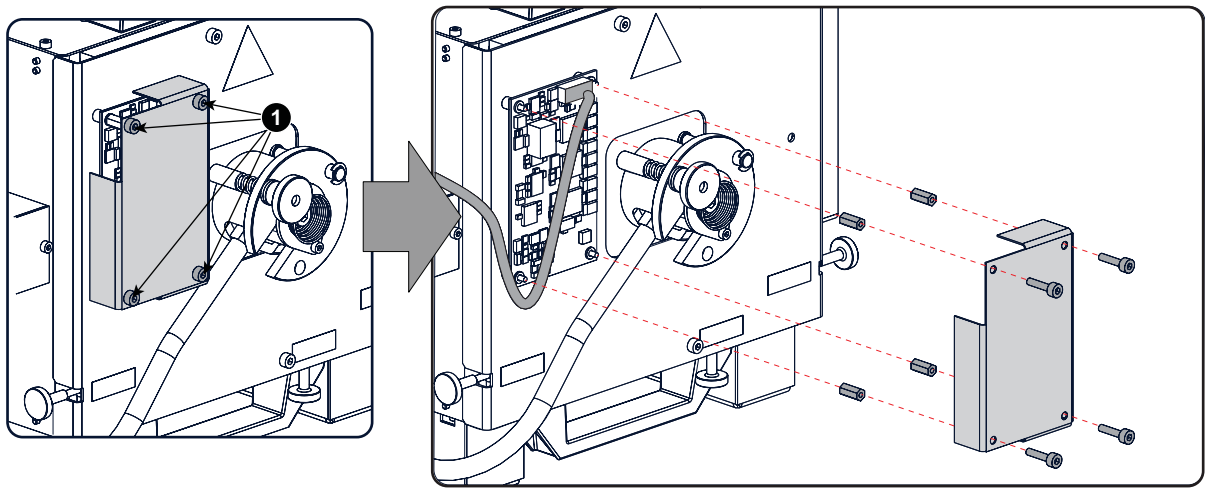

Image 6-30

2. Disconnect the wire unit (reference C) from the Lamp Info module as illustrated.

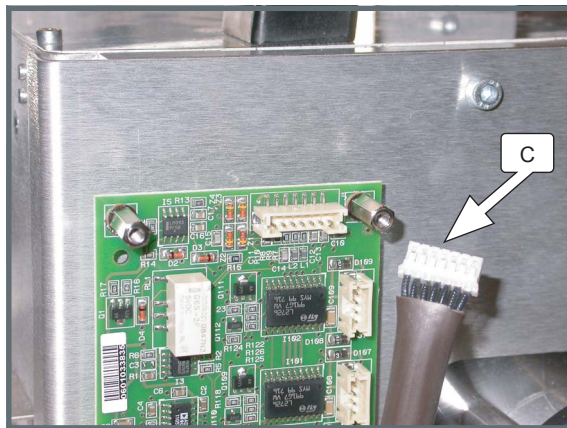

Image 6-31

3. Remove the Lamp Info module from the lamp house by releasing the four spacers (reference 2) as illustrated. Use a 5 mm nut driver. Do not loose the isolating rings (reference 3).

6. Lamps and lamp houses

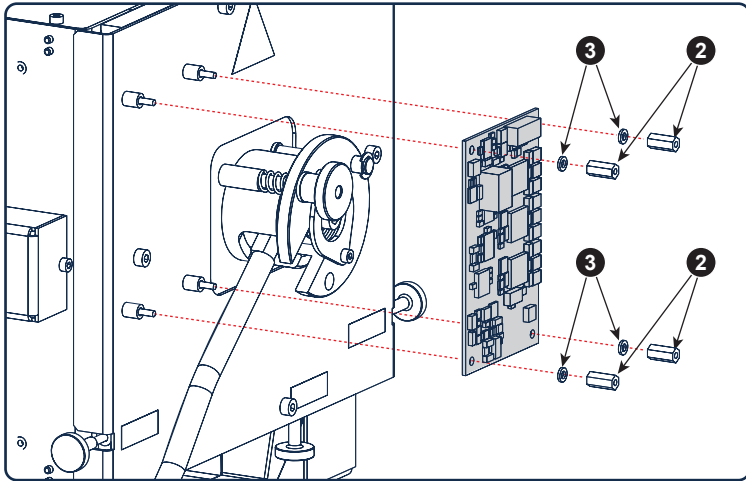

Image 6-32

4. Reinstall a new Lamp Info module and fasten with four spacers (reference 2 image 6-32). Make sure to place a isolating ring (reference 3 image 6-32) between the module and the spacer. Use a 5mm nut driver.
5. Reconnect the wire unit (reference C) as illustrated.

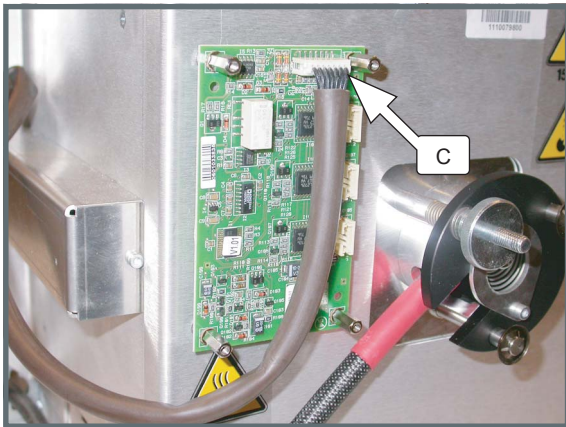

Image 6-33

6. Reinstall the cover of the Lamp Info module. Fasten with four hexagon socket head cap screws (reference 1 image 6-30). Use a 2,5 mm Allen wrench

6.9 Replacement of the UV blocker



This procedure is only valid when replacing an UV blocker with an glued or screwed anode support.



This procedure requires that the lamp house is removed from the projector. See procedure "Removal of the lamp house", page 96.



CAUTION: The person that performs this procedure **MUST** be wearing a full face shield with neck protector, a welder's jacket and clean leather gloves with wrist protectors. This is required to safely dismantle or assemble the lamp house, which contains a xenon lamp.

Necessary tools

2,5 mm Allen wrench.

How to replace the UV blocker

1. Ensure that you wear protective clothing, a full face shield and protective gloves.
2. Remove first the lamps house side cover and then the lamp house UV blocker assembly by releasing the retaining thumbscrews as illustrated. Support the xenon lamp while removing the UV blocker assembly.

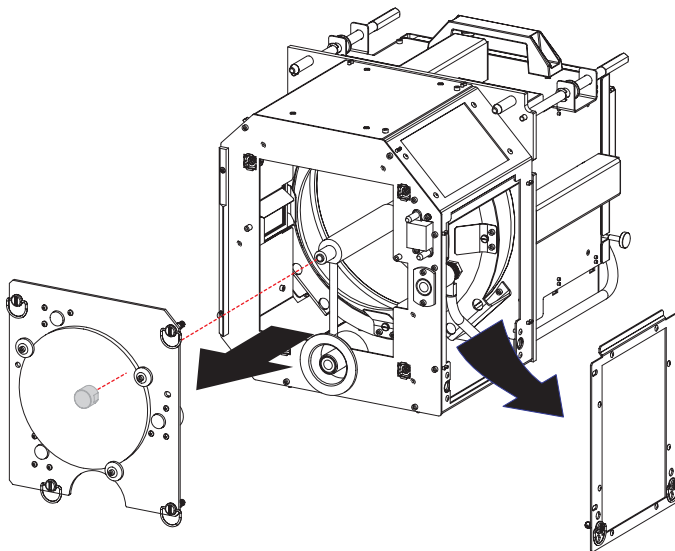

Image 6-34

3. Replace the UV blocker with integrated anode support as illustrated. Use a 2,5 mm Allen wrench to loosen/fasten the three hexagon socket head cap screws (reference 3). Make sure that the anode support is on the inner side of the assembly.

Caution: Do not touch the new UV blocker with bare fingers. You should wear clean leather gloves to protect your hands against the danger of explosion of the high pressurized xenon lamp and to avoid that the UV blocker gets contaminated with grease or dirt. You may wear latex or cotton gloves in case there is no danger of a highly pressurized xenon lamp.

6. Lamps and lamp houses

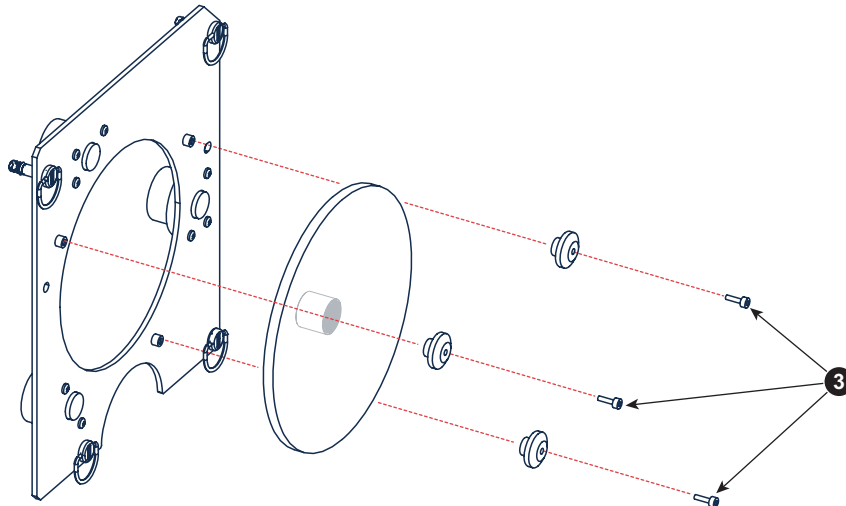

Image 6-35

4. Reinstall the UV blocker assembly as illustrated. Make sure that the xenon lamp is properly supported by the lamp supporting mechanism in the centre of the UV blocker. Use the opening at the side of the lamp house to guide the supporting pin of the xenon lamp into the anode supporting mechanism.

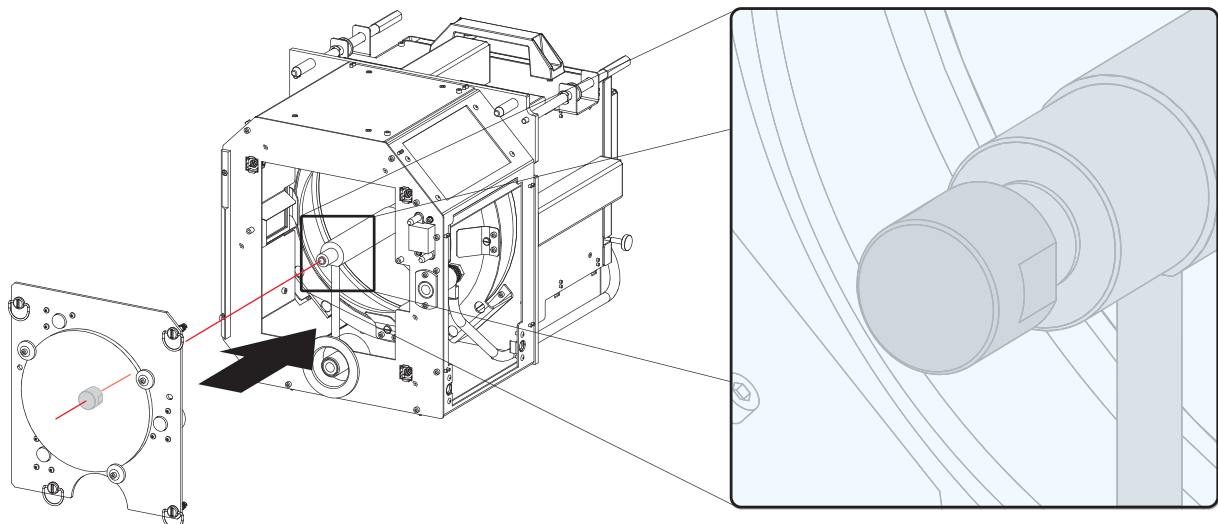

Image 6-36

5. Secure the UV blocker by fastening the four retaining thumbscrews as illustrated.

Note: Please ensure that the retaining thumb screws turning wires are flash with the cover or interference will occur while inserting the lamp house into the projector.

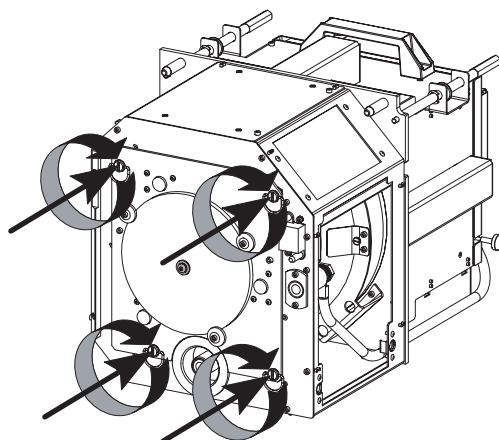

Image 6-37

6. Reinstall the side cover of the lamp house as illustrated.

Note: Please ensure that the retaining thumb screws turning wires are flash with the cover or interference will occur while inserting the lamp house into the projector.

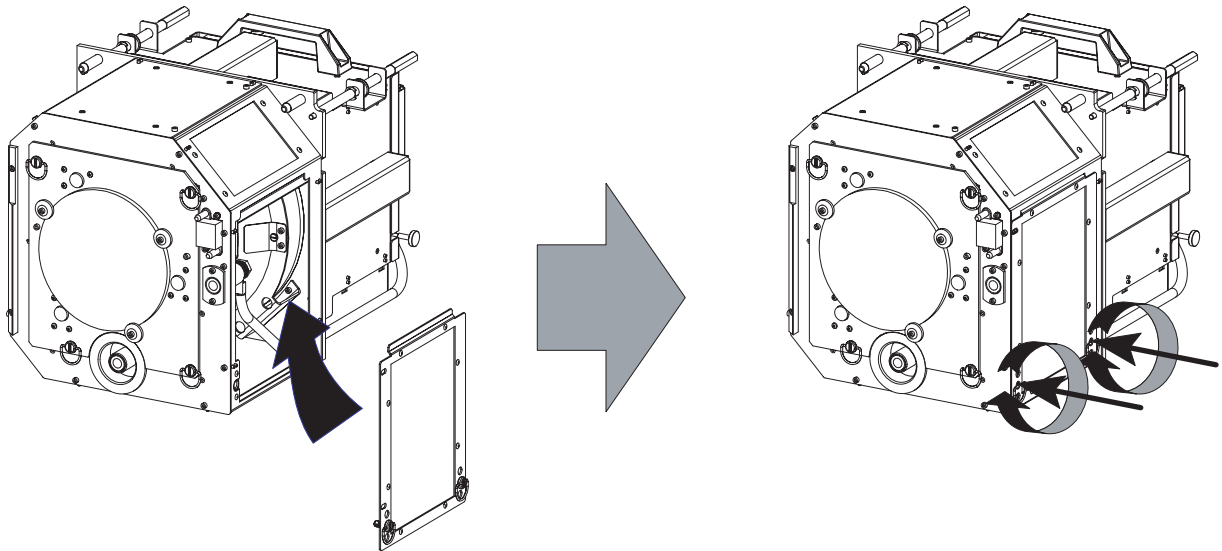

Image 6-38

6.10 Replacement of the lamp reflector

Lamp reflector assembly

The reflector of the lamp has three major parts. One mounting plate, one spheric glass mirror and one elliptic glass mirror. Both mirrors are glued on the mounting plate and are perfectly aligned with each other. The mounting plate serves also as a reference plate between the reflector and the projector optics. The mounting plate has two positioning pins which ensure a correct alignment of the reflector assembly with respect to the projector once the lamp house is inserted in the projector.

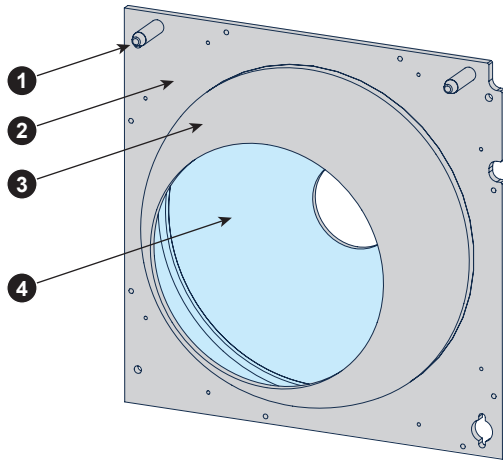

Image 6-39

- 1 Positioning pin.
- 2 Mounting plate.
- 3 Spheric glass mirror.
- 4 Elliptic glass mirror.



This procedure assumes that there is no lamp installed inside the lamp house. If so, see procedure "Removal of the xenon lamp", page 98.



CAUTION: Do not touch the glass of the reflector assembly while unpacking and installing. Hold fast the reflector assembly by its metal mounting plate.

Necessary tools

- Two 17 mm open-end wrenches.
- Torque wrench with 17 mm hexagon socket.
- 2,5 mm Allen wrench.

How to replace the reflector of the lamp house?

1. Remove the side cover of the lamp house by releasing the two retaining thumbscrews as illustrated.

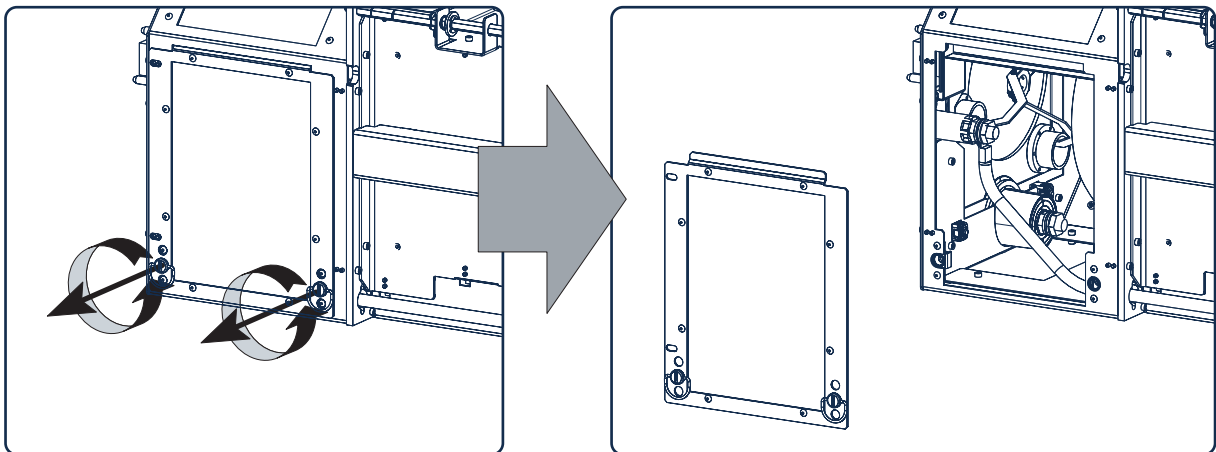

Image 6-40

2. Disconnect one end of the cathode wire from the lamp house as illustrated. Use two open-end wrenches to release the nuts.
Tip: Place the washers and nuts back on the socket.

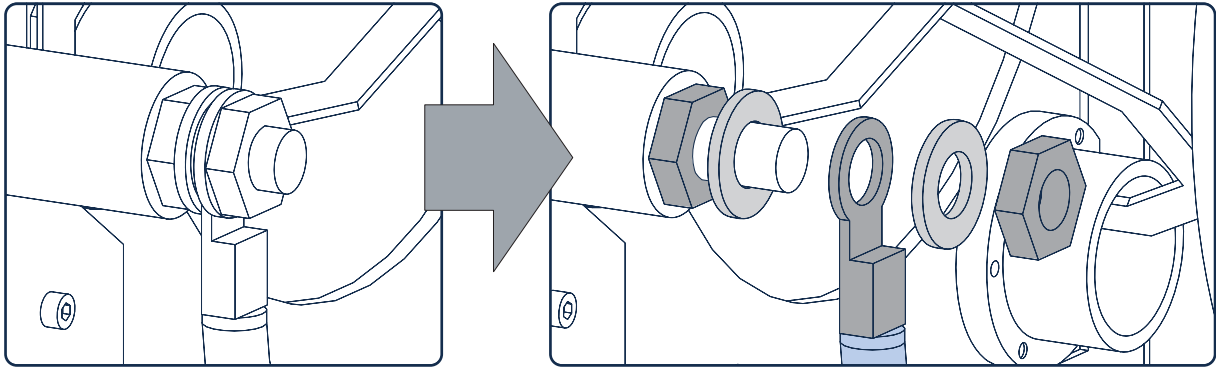

Image 6-41

3. Guide the cathode wire through the hole out of the lamp house.

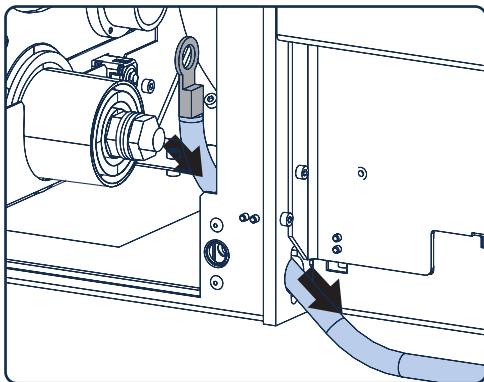

Image 6-42

4. Place the lamp house upon the anode side as illustrated and remove the bottom profiles. Use a 2,5 mm Allen wrench to release the hexagon socket head cap screws of the bottom profiles.

Caution: Do not damage the UV blocker or the blue electrical socket of the lamp house.

Tip: Let the three spacers of the UV blocker rest upon a clean flat surface (e.g. a thick book).

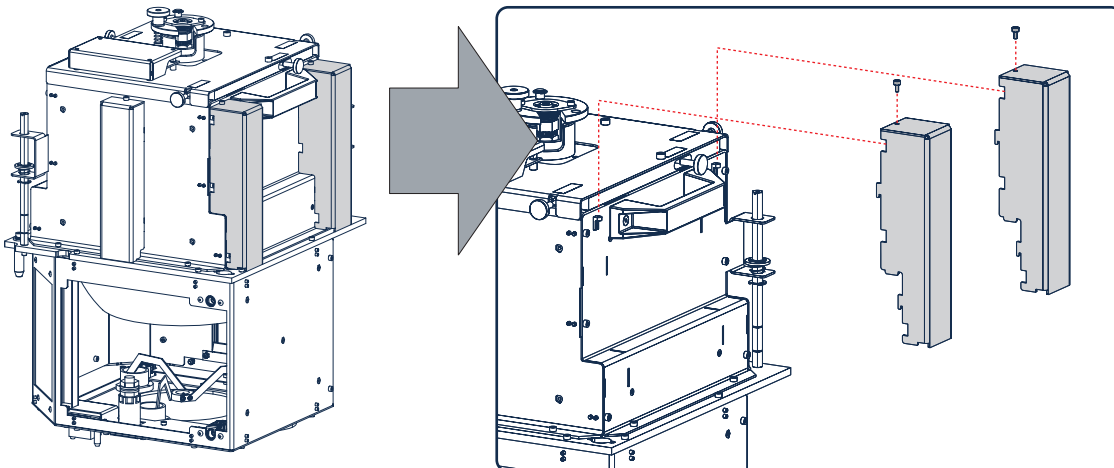

Image 6-43

5. Remove the cathode side of the lamp house by releasing 8 hexagon socket head cap screws (reference 6, two screws per side) as illustrated in image 6-44. Use a 2,5 mm Allen wrench.
6. Remove the reflector assembly of the lamp house by releasing 8 hexagon socket head cap screws (reference 7, two screws per side) as illustrated. Use a 2,5 mm Allen wrench. Note that these screws are longer than those screws which you removed in the previous step.

6. Lamps and lamp houses

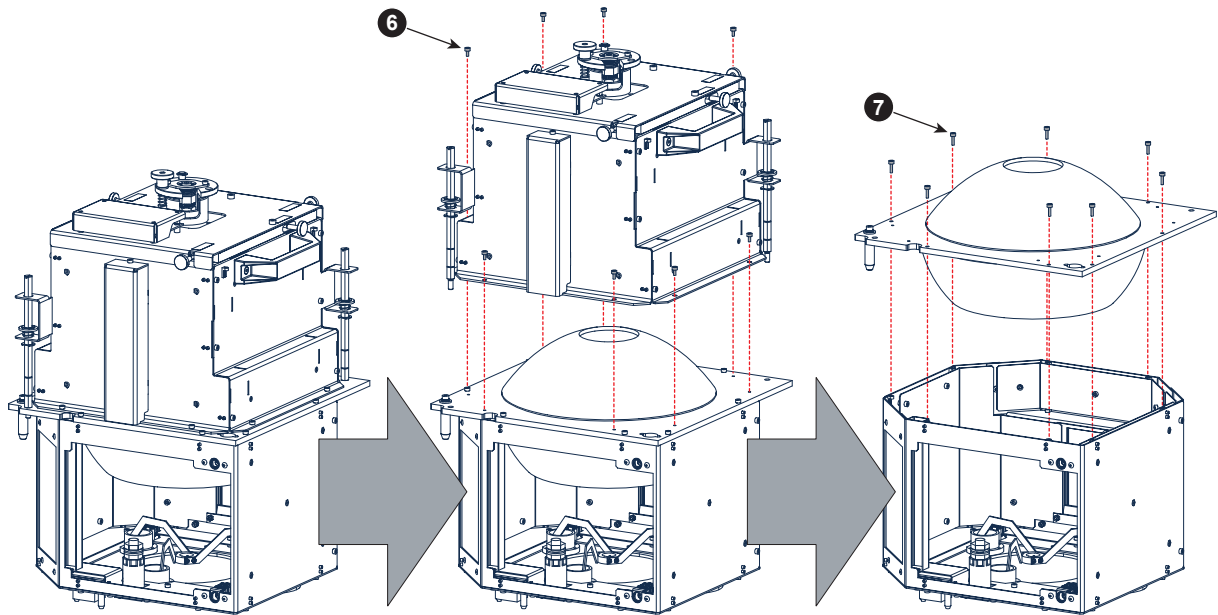

Image 6-44

7. Place a new reflector assembly upon the anode side of the lamp house and fasten with 8 hexagon head cap screws (reference 7 image 6-44). Use a 2,5 mm Allen wrench. These screws must have a length of 10 mm. Make sure to position the reflector assembly correctly.
Caution: Do not touch the glass of the reflector assembly. Hold fast the reflector assembly by its metal mounting plate.
8. Reinstall the cathode side of the lamp house (see middle drawing of image 6-44). Fasten with 8 hexagon head cap screws (reference 6 image 6-44). Use a 2,5 mm Allen wrench.
9. Reinstall the bottom profiles. See image 6-43. Use a 2,5 mm Allen wrench.
10. Guide the cathode wire inside the lamp house as illustrated.

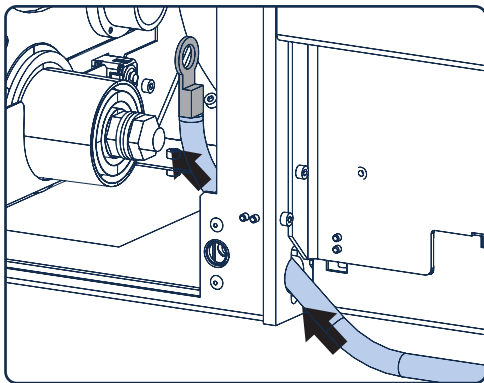

Image 6-45

11. Reconnect the cathode wire with the lamp house. Make sure to place a washer (reference 2 and 4) between the nuts and the eye of the cathode wire (reference 3). Use a torque of 9 Nm to fasten the nuts (reference 1 and 5). Block the first nut (reference 1) with a 17 mm open-end wrench while applying a torque of 9 Nm on the second nut (reference 5) with a torque wrench.

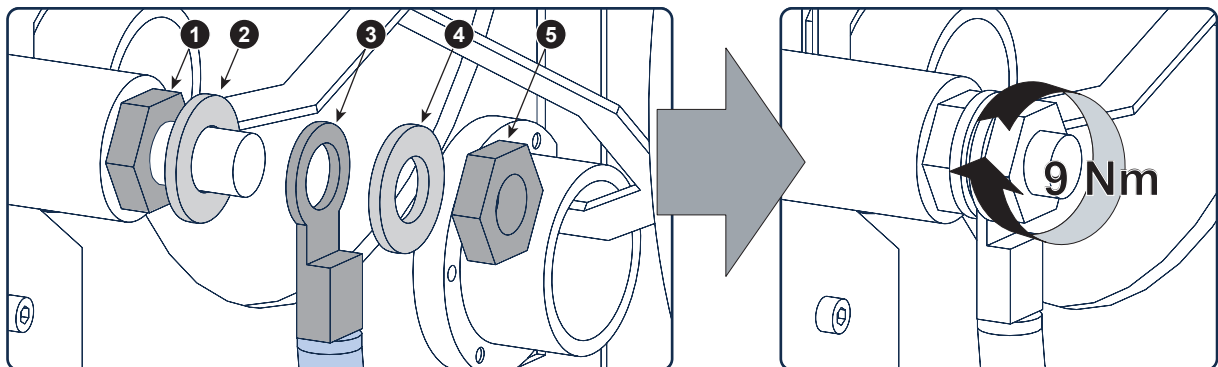

Image 6-46

12. Reinstall the side cover of the lamp house.

6.11 Cleaning the Reflector of the Lamp House

When cleaning the Reflector?

Clean the Reflector on a regular basis to maintain light output level.



This procedure requires that the lamp is removed from the Lamp House.

Necessary tools

- Compressed air.
- Clean Toraysee® cloth or any micro fiber lens cleaning cloth.
- Clean cotton cloth.

Necessary parts

Lens cleaner (e.g. Carl Zeiss lens cleaner or Purasol® or any waterbased lens cleaner)

How to clean the Reflector of the Lamp House?

1. Blow off dust with clean compressed air (or pressurized air cans).
 2. Clean with lens cleaner together with a clean lens cleaning cloth to remove the dust and contamination. Use big wipes.
 3. Use a dry lens cleaning cloth to remove left liquid or stripes. Polish with small circles.
 4. If there are still fingerprints on the surface, wipe them off with lens cleaner together with a clean lens cleaning cloth. Polish again with a dry one.
-



CAUTION: Never use a Lamp House with cracked or damaged Reflector. Neglecting this may result in irreversible damage of the projector.

6.12 Cleaning the UV blocker of the Lamp House

When cleaning the UV blocker?

Clean UV blocker on regular basis to maintain light output level.



This procedure requires that the UV blocker is removed from the Lamp House.

Necessary tools

- Compressed air.
- Clean Toraysee® cloth or any micro fiber lens cleaning cloth.
- Clean cotton cloth.

Necessary parts

Lens cleaner (e.g. Carl Zeiss lens cleaner or Purasol® or any waterbased lens cleaner)

How to clean the UV blocker of the Lamp House?

1. Blow off dust with clean compressed air (or pressurized air cans).
2. Clean with lens cleaner together with a clean lens cleaning cloth to remove the dust and contamination. Use big wipes.
3. Use a dry lens cleaning cloth to remove left liquid or stripes. Polish with small circles.
4. If there are still fingerprints on the surface, wipe them off with lens cleaner together with a clean lens cleaning cloth. Polish again with a dry one.



CAUTION: Never reinstall a UV blocker which is cracked or has a damaged coating. Neglecting this will result in irreversible damage of optical parts in the projector.

7. COLD MIRROR ASSEMBLY

About this chapter

This chapter describes how to replace the cold mirror and top fan as complete assembly. It also describes the necessary adjustments for the cold mirror.



CAUTION: Typically the Cold Mirror should never be readjusted in the field except when the Cold Mirror or Lamp Reflector have been replaced. In case a readjustment is required follow the instructions in this chapter precisely. Only qualified technicians who have experience with adjusting the Cold Mirror may adjust the Cold Mirror. A misaligned Cold Mirror may cause irreversible damage to other parts of the projector!

Overview

- Introduction
- Removal of the cold mirror assembly
- Replace the Cold Mirror
- Installation of the cold mirror assembly
- Adjusting the cold mirror
- Cleaning the Cold Mirror

7.1 Introduction

Functionality of the cold mirror

The location of the cold mirror in the light path is between the light source (xenon lamp) and the light pipe. The cold mirror reflects the visible light and absorbs the infra red light. Due to this absorbing, a lot of heat is produced. The cold mirror is mounted with the rear side upon a big heat sink. The fan above the heat sink blows cold air upon the heat sink and cold. The hot air is transported to the outside of the projector. The cold mirror has three adjustment screws to modify the position of the cold mirror so that the centre of the light spot is precisely reflected in the centre of the integration rod entrance for optimal performance.

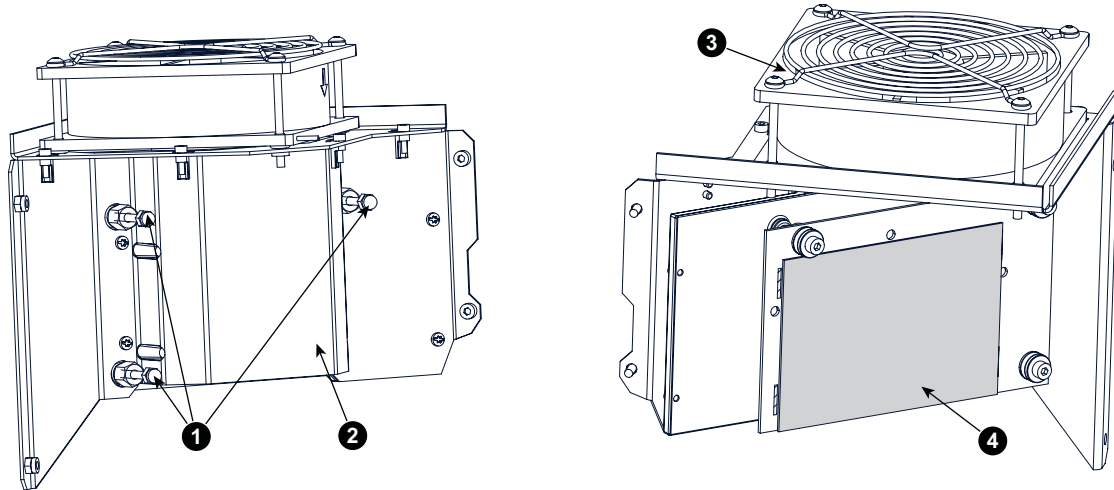

Image 7-1
Cold mirror assembly

1 Cold mirror adjustment screws

Diagnostic

The easiest way to check the condition of the cold mirror is by removing the lamp unit. When the lamp unit is removed, the cold mirror becomes visible at the end of the lamp compartment. In case the cold mirror is not damaged but dirt is clearly visible upon the surface of the mirror it is recommended to clean the cold mirror. Always replace the cold mirror with a new one in case the cold mirror is damaged. Possible damages are:

- Cold mirror is broken.
- Coating peels off.
- Cold mirror is cracked.

7.2 Removal of the cold mirror assembly



The cold mirror cannot be replaced separately. Always replace the whole assembly (mirror + heat sink + fan).

Necessary tools

- 3 mm Allen wrench
- Nut driver 7 mm

How to remove the cold mirror assembly

1. Remove cover plate of the sealed compartment. See "Open the sealed compartment", page 85.
2. Remove the cover of the Start Pulse Generator as illustrated. This cover is secured with 5 hexagon socket head cap screws. Use a 3 mm Allen wrench.

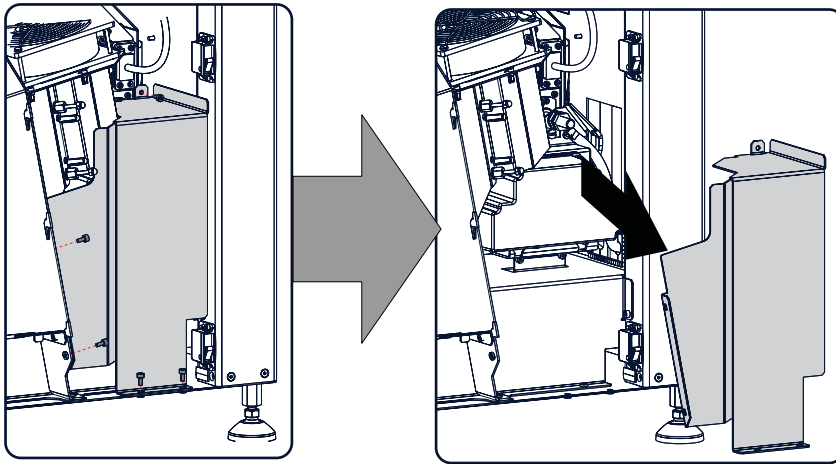

Image 7-2
Remove SPG cover

3. Disconnect the fan wire (reference 1).

Tip: Pull out the top filter for easy access to the fan wire connection.

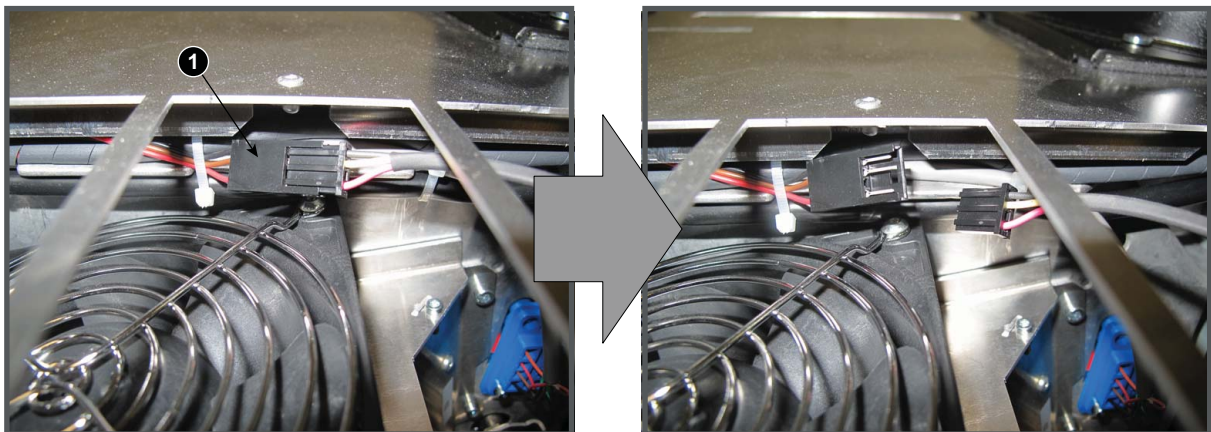

Image 7-3
Electrical disconnection

4. Turn out the 2 hexagon socket head cap screws at the right side (reference 2).

7. Cold mirror assembly

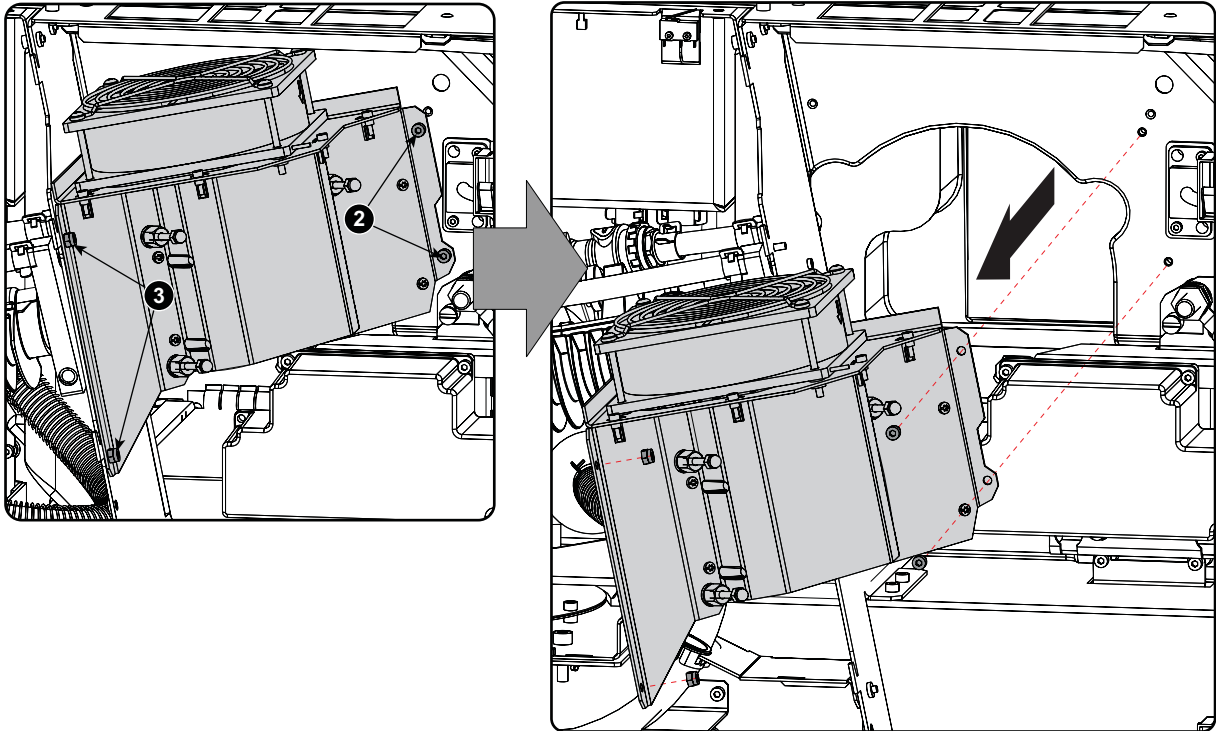

Image 7-4
Remove cold mirror

5. Remove both nuts at the left side (reference 3). Support the assembly while removing the nuts.
6. Slide out the cold mirror assembly.

7.3 Replace the Cold Mirror

Necessary tools

- 7mm nut driver.
- 7mm open-end wrench.
- 3mm Allen wrench.
- Latex or cotton gloves.
- Slide caliper.

How to replace the Cold Mirror?

1. Loosen the three nuts (reference 11) at the rear side of the Cold Mirror. Use a 7mm open-end wrench.
2. Loosen the three lock nuts (reference 10) at the rear side of the Cold Mirror. Use a 7mm open-end wrench.
3. Loosen the three long screws (reference 1) at the front side of the Cold Mirror. Use a 3 mm Allen wrench.
4. Remove the small components (reference 5, 6, 7, 8 & 9) from the long screws (reference 1) and take of the Cold Mirror.
5. Install the new Cold Mirror. Ensure that all mounting parts (reference 1 to 9) upon the three long screws are placed in that order as illustrated.

Caution: Do not touch the surface of the Cold Mirror. Use cotton gloves to handle the Cold Mirror.

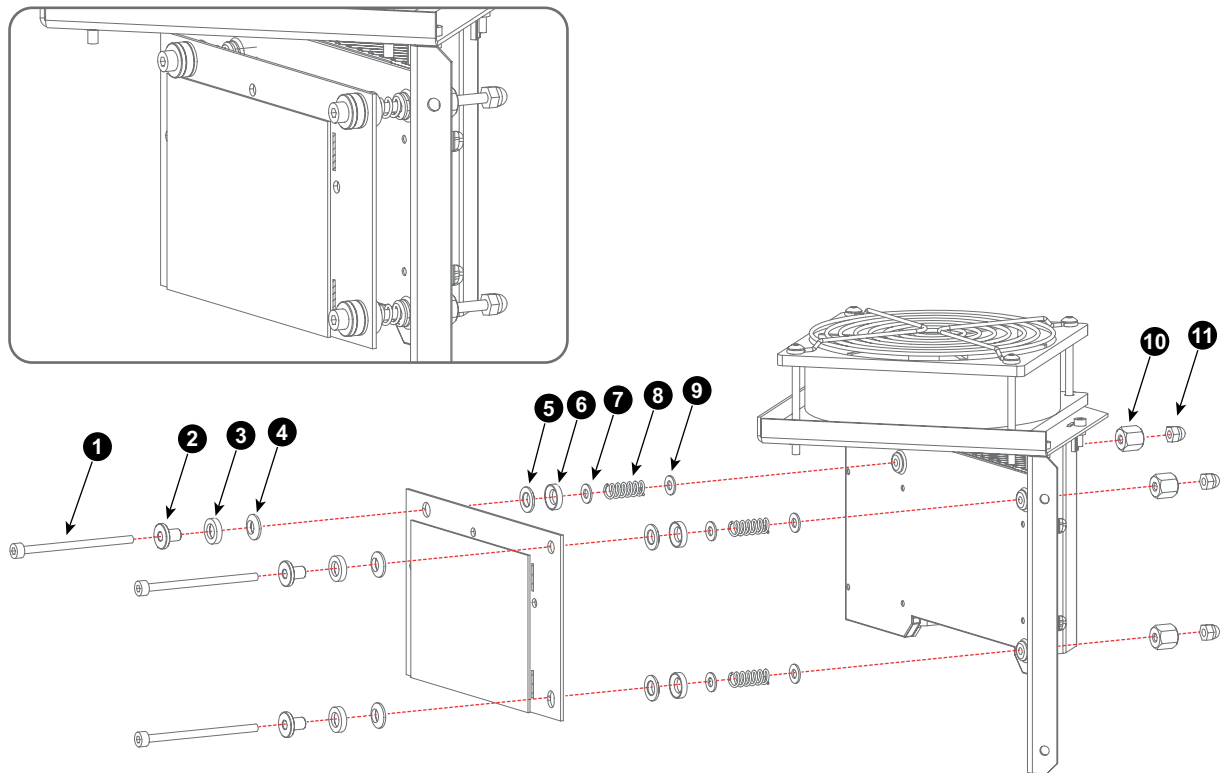

Image 7-5

6. Tighten the three long screws until the distance between the Cold Mirror and frame is 17.4mm. Tighten the lower lock nut until the distance between the Cold Mirror and the frame is 17.4mm.

7. Cold mirror assembly

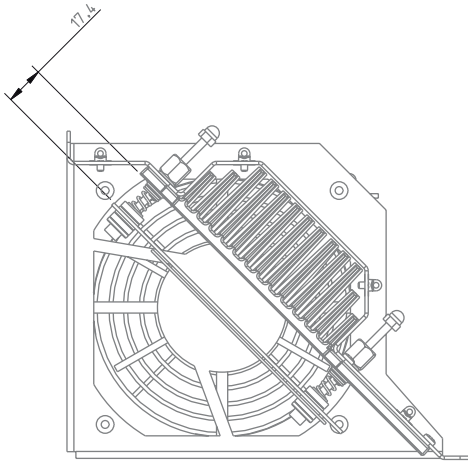

Image 7-6

7. Place a lock nut (reference 10) and a cap nut (reference 11) at the end of each long screw (reference 1).

Note: While tightening the lock nuts ensure that the distance between the Cold Mirror and frame remains 17.4mm. This position of the screws correspond with nearly an optimal position of the mirror.

7.4 Installation of the cold mirror assembly



The cold mirror cannot be replaced separately. Always replace the whole assembly (mirror + heat sink + fan).

Necessary tools

- 3 mm Allen wrench
- Nut driver 7 mm



When unpacking the cold mirror assembly, check if there is no foam piece between the support plate and the backside of the cold mirror. If so, remove that piece gently.

Remove the protective layer on the mirror side. Do not touch the mirror with your fingers or other object.

How to install the cold mirror assembly

1. Insert the cold mirror assembly on its place and hold the cold mirror assembly in its place. Secure with the two nuts (reference 1) at the left side. Use a 7 mm nut driver.

Caution: Make sure that the wire unit of the fan does not get jammed between the assembly and the projector chassis.

Caution: Do not touch the surface of the cold mirror.

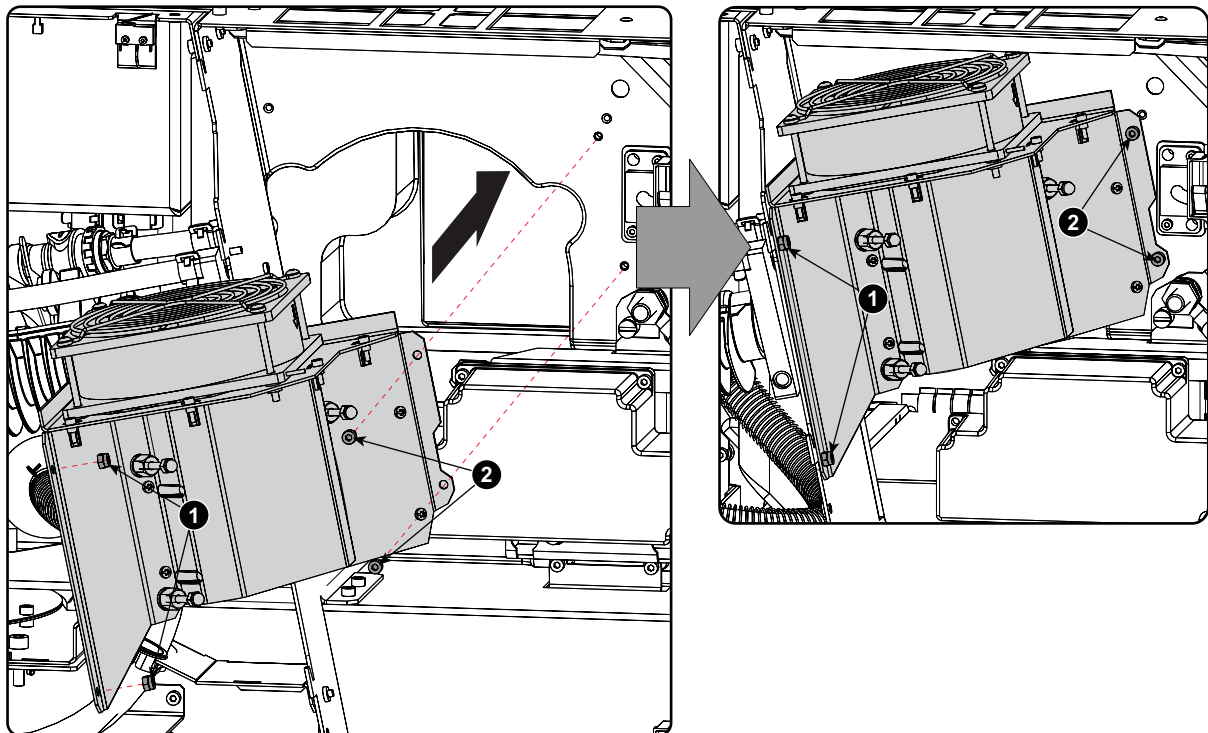

Image 7-7
Mount cold mirror

2. Fasten the right side of the cold mirror assembly using two hexagon socket head cap screws (reference 2). Use a 3 mm Allen wrench.
3. Reconnect the wire unit (reference 3) of the fan.

7. Cold mirror assembly

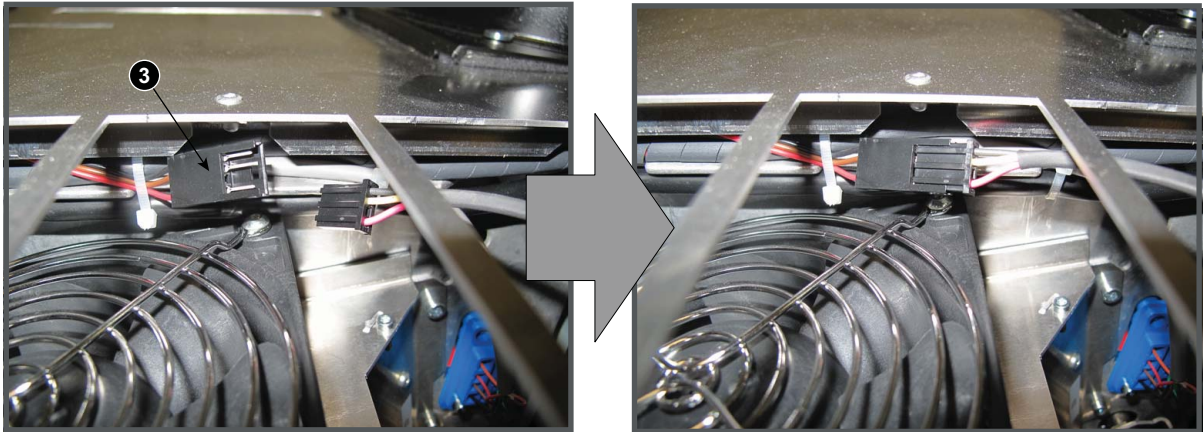

Image 7-8

4. Install the cover of the Start Pulse Generator as illustrated. The cover has to be fastened with 5 hexagon socket head cap screws. Use for that a 3 mm Allen wrench.

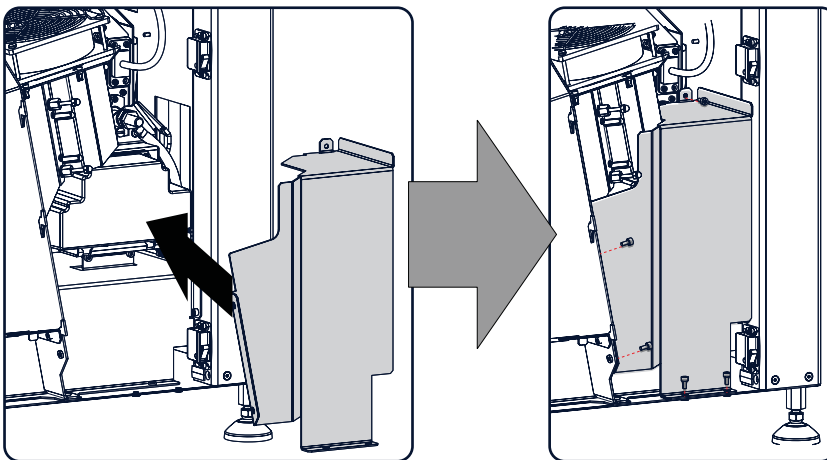

Image 7-9

5. Close the sealed compartment. See "Close the sealed compartment", page 86.
6. Readjust the cold mirror. See "Adjusting the cold mirror", page 131.

7.5 Adjusting the cold mirror



The position of the xenon bulb in its reflector effects the position of the cold mirror with respect to the entrance of the integration rod. Hence the adjustment of the cold mirror requires simultaneous adjustment of the xenon bulb in its reflector for maximum light output. Once the cold mirror and xenon bulb are optimally adjusted, the cold mirror should never be adjusted again. A xenon bulb replacement only requires realignment of the lamp in its reflector. Only when a cold mirror is replaced, should it be readjusted.

Necessary tools

- 10 mm open-end wrench.
- 7 mm nut driver.
- Light meter.
- Slide caliper.

How to setup the projector for adjusting the cold mirror?

1. Remove the left cover and lamp cover of the projector.
2. Loosen the three lock nuts (reference 4 image 7-10) of the cold mirror adjustment screws. Use for that a 10 mm open-end wrench.

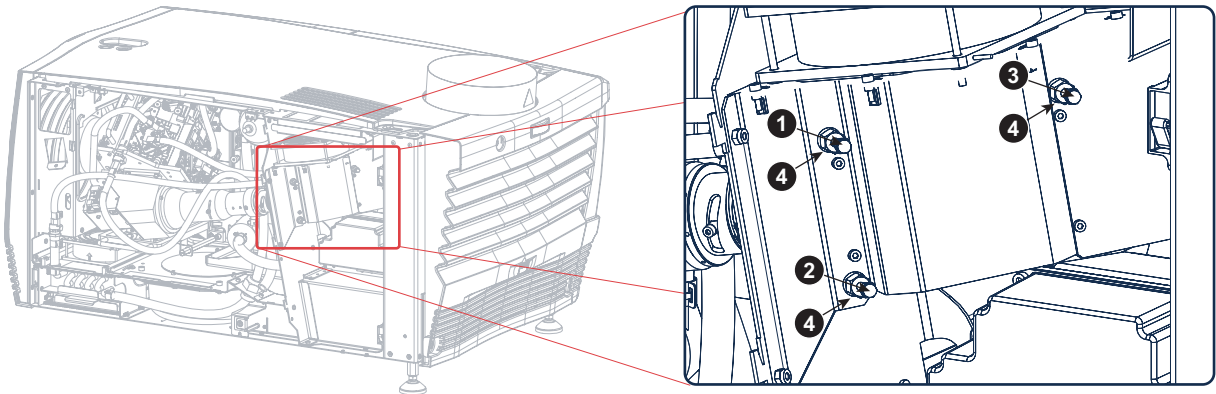

Image 7-10

3. Check the nominal position of the cold mirror and if required adjust. The distance between the head of the each adjustment screw (reference 1, 2 & 3 image 7-10) and the assembly plate should be 32,5 mm for nominal position. This distance corresponds with 17,4 mm between the cold mirror and its mounting surface. This nominal position is the best position to start the adjustment procedure. Normally the cold mirror spare part is delivered with the cold mirror in its nominal position.

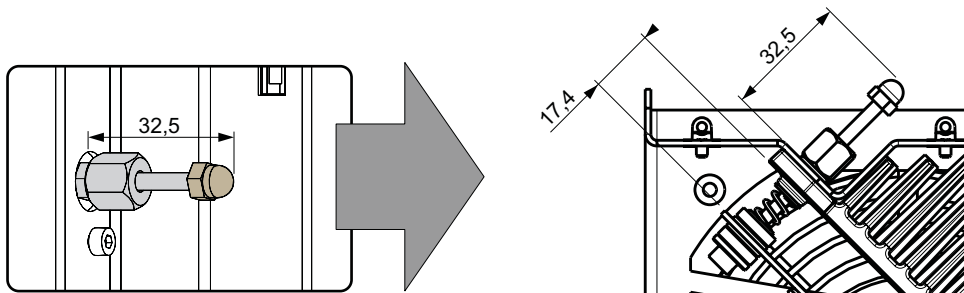

Image 7-11

4. Project a white test pattern.
5. Place the light meter in the center of the projected image.

How to adjust the cold mirror?

1. Turn the adjustment screw 2 (reference 2 image 7-12) in or out until the maximum light output is measured. Use for that a 7 mm nut driver.

7. Cold mirror assembly

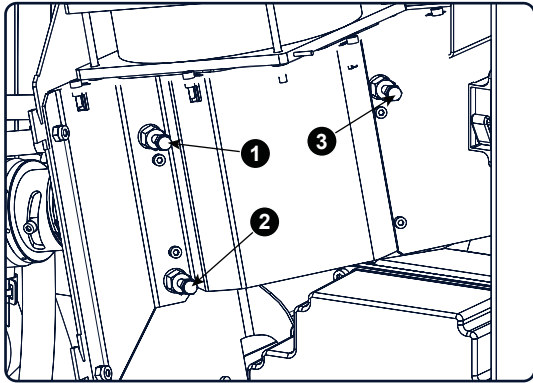
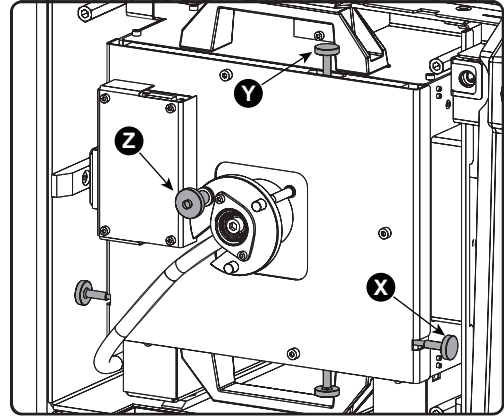

Image 7-12



2. Turn the adjustment screw 3 (reference 3 image 7-12) in or out until the maximum light output is measured.
3. Repeat step 1 and 2 until the maximum light output is measured.
4. Adjust the X-axis, Y-axis and Z-axis (reference X, Y & Z image 7-12) of the xenon lamp in the Lamp House for maximum light output. Carefully turn the thumbscrew for maximum light output. Once over the maximum, turn slightly in opposite direction to reach the maximum light output again. Do this for each direction and minimum repeat this adjustment cycle twice.
5. Turn the adjustment screw 1, 2 and 3 (reference 1, 2 & 3 image 7-12) equally in or out until the maximum light output is measured.
6. Repeat from step 1 until the maximum light output is measured.
7. Check the brightness uniformity. In most cases it will be OK.
If not OK, turn slightly on the adjustment screws 2 and 3 (reference 2 & 3 image 7-12) until a uniform brightness is obtained.
 - Screw 2 (reference 2 image 7-12) will correct the difference between the left and the right side of the projected image.
 - Screw 3 (reference 3 image 7-12) will correct the difference between the top and the bottom side of the projected image.Check again and repeat if necessary.
8. When the adjustment is finished, secure the position of the cold mirror by turning the lock nuts (reference 4 image 7-12) against the plate (hold on the screws while securing the nuts).

7.6 Cleaning the Cold Mirror

When cleaning the Cold Mirror?

Clean the Cold Mirror on a regular basis to maintain light output level.



This procedure requires that the Lamp House is removed from the projector.

Necessary tools

- Compressed air.
- Clean Toraysee® cloth or any micro fiber lens cleaning cloth.
- Clean cotton cloth.

Necessary parts

Lens cleaner (e.g. Carl Zeiss lens cleaner or Purasol® or any waterbased lens cleaner)

How to clean the Cold Mirror?

1. Blow off dust with clean compressed air (or pressurized air cans).
2. Clean with lens cleaner together with a clean lens cleaning cloth to remove the dust and contamination. Use big wipes.
3. Use a dry lens cleaning cloth to remove left liquid or stripes. Polish with small circles.
4. If there are still fingerprints on the surface, wipe them off with lens cleaner together with a clean lens cleaning cloth. Polish again with a dry one.

8. LIGHT PROCESSOR ASSEMBLY

About this chapter

This chapter describes how to replace the complete light processor assembly. Furthermore, this chapter includes the replacement procedure of some sub assemblies. The information about the convergence adjustment and the integration rod is grouped in separate chapters.

Overview

- Introduction
- Light processor diagnostic
- Remove light processor top cover
- Electrical disconnection
- Light processor assembly removal
- Preparing the new light processor assembly
- Installation of the light processor assembly
- Electrical connections
- Mount light processor cover
- Mount light processor assembly into the flight case
- Finalize the installation of the light processor assembly
- Replacement of the Light Sensor Module
- Replacement of the dowser (shutter)
- Adjusting the notch filter
- Cleaning the Prism exit side

Preparations

First execute the following steps to access the light processor assembly:

- Remove the side cover, see "Removal of the side cover", page 81.
- Remove the top cover, see "Removal of the top cover", page 83.
- Open the sealed compartment, see "Open the sealed compartment", page 85.

8.1 Introduction

Light Processor assembly

The light processor assembly has three major sub assemblies, namely: the Light Processor Unit (reference 1) with dowser (reference 2) and the Light Pipe assembly (reference 3).

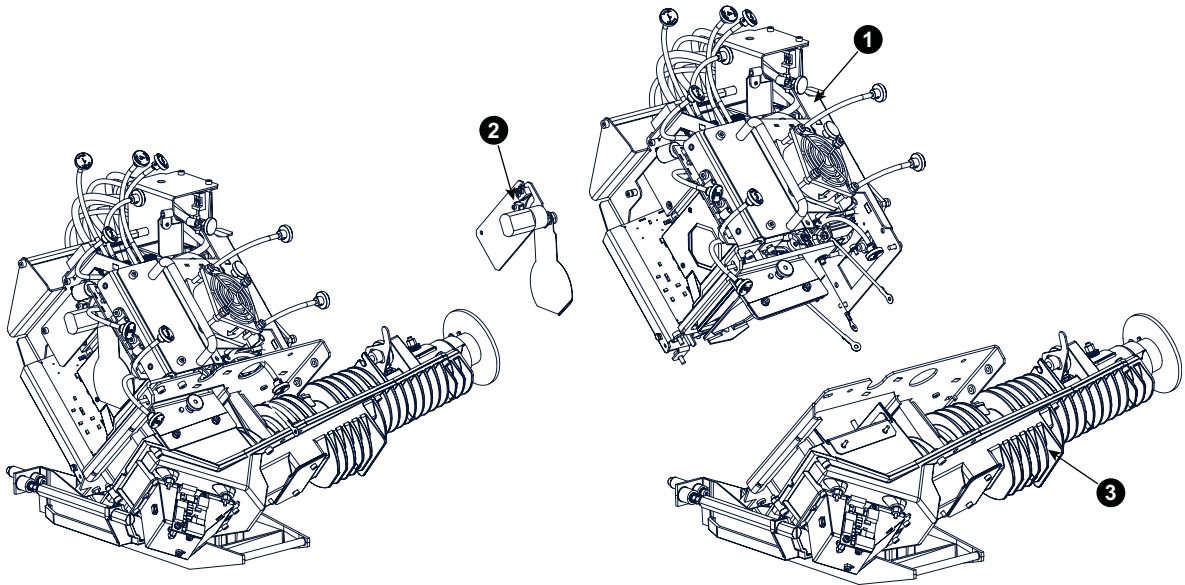

Image 8-1
Light processor assembly

Light Pipe

The Light Pipe transforms the light emitted by the lamp into a homogeneous light beam and focuses this beam precisely on the active surface of the DMD's. The Light Pipe contains the Integration Rod at the Light Pipe entrance, the Light Pipe focus and rotation knobs which matches the size of the light beam with the size of the DMD's, the Folding Mirror which folding up the light path of the projector to make the projector more compact, and the Light Sensor Module which ensures a Constant Light Output (CLO) of the projector. Furthermore, the Light Pipe has a Notch filter on the exit which applies some small color corrections on the light coming out of the Light Pipe.

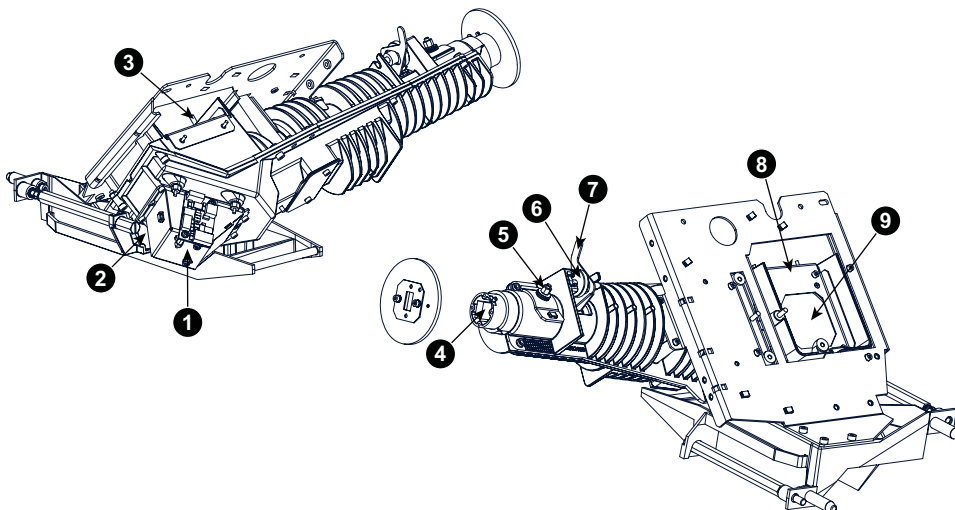

Image 8-2
Light pipe assembly

- 1 Light sensor unit
- 2 Fold mirror cover
- 3 Notch filter adjustment
- 4 Rod entrance
- 5 Rod lock nut
- 6 Rod focus knob
- 7 Rod focus lever
- 8 Notch filter
- 9 Fold mirror

Light Processor

The Light Processor is the heart of the projector. The prism of the Light Processor splits up the homogeneous white light coming from the Light Pipe into red, green and blue light. The video information on the three DMD's is integrated with these red green and

blue light beams. The prism merges the three integrated light beams back in to one full color video image, which is projected via the lens onto the screen.

Each DMD has its own formatting board which drives the micro mirrors to integrate the video signal into the light beam. A lot of heat is produced during the integration of the video information. To protect the DMD's for overheating the Light Processor is equipped with fans and heat sinks. Each channel has its own fan and heat sink.

The red and green channel are equipped with three extended adjustment knobs to convergence the DMD with the DMD of the blue channel which is the reference channel for convergence alignment.

The air gab between the prism and DMD is sealed to protect the DMD's for dust. It is important to know that a misaligned light path which reflects upon the sealing will damage the sealing very rapidly. At the bottom of the prism exit a "touch" sensor is mounted to protect the prism against accidental lens movements. Note that the Light Processor Unit is equipped with a motorized shutter (dowser) in front of the prism exit.

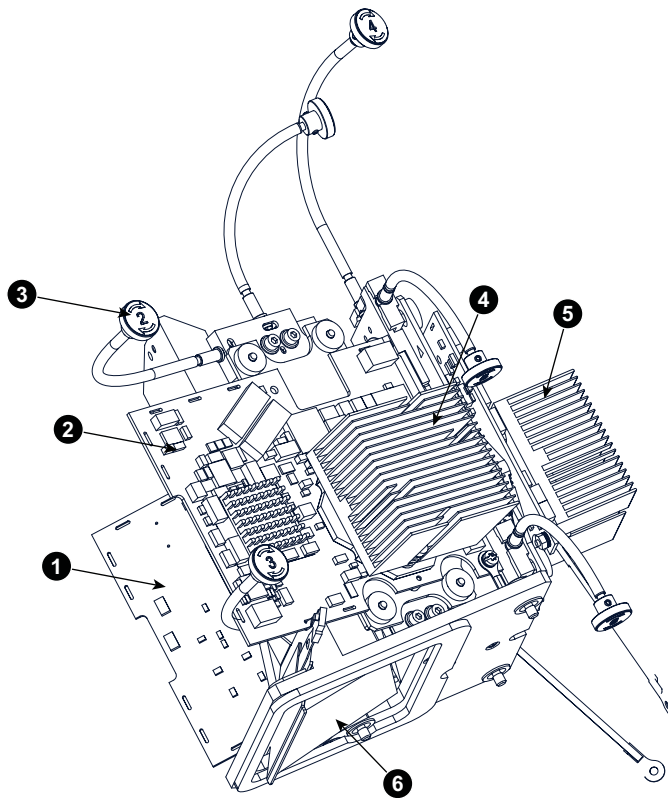

Image 8-3
Light processor

- 1 Formatting board blue channel
- 2 Formatting board green channel
- 3 Convergence adjustment knob
- 4 Cooling block green channel
- 5 Cooling block red channel
- 6 Prism exit

8.2 Light processor diagnostic

Troubleshooting of the Light Processor assembly

There are several reasons why a removal or a replacement of the Light Processor is required. Nevertheless, try to avoid unnecessary removal of the Light Processor. The list below gives an overview of the most common problems which require removal or replacement of the Light Processor. Check this list to ensure the problem is caused by the Light Processor.

- Artifacts in the projected image. These artifacts are also visible on the internal service patterns of the Formatter boards.
- A crack in the prism, which can result in convergence problems and may disable you to focus the projected image.
- Damaged integration rod, which causes permanent spots in the projected image.
- Blocked dowsers (shutter). Dowsers do not respond when pressing the "DOWSER" button.
- Blocked cooling fan



Check the projector log files for errors or warnings and look for a solution in the chapter "Troubleshooting", page 27.

8.3 Remove light processor top cover

Necessary tools

No tools.

How to remove

1. Slide the cover forward so that the side hooks are unlocked (1).

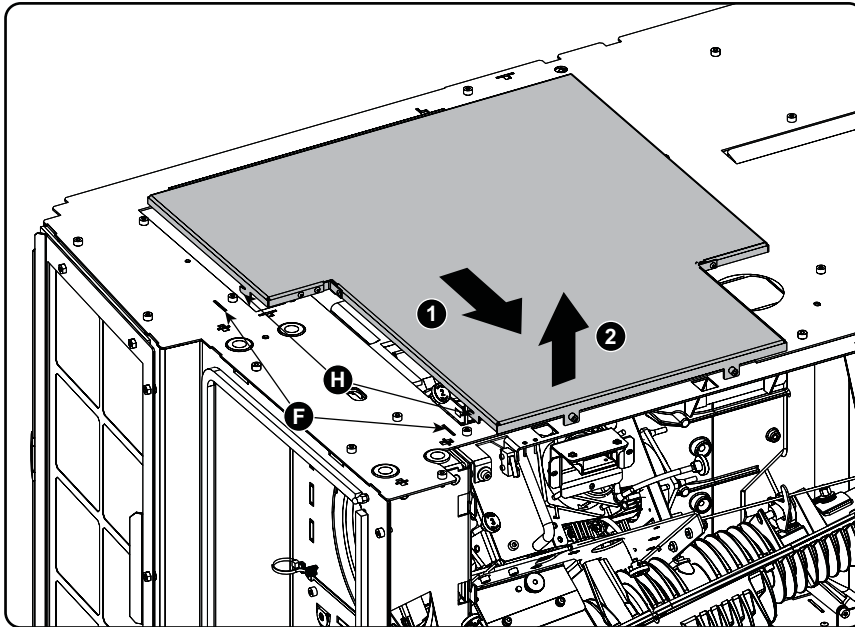

Image 8-4
Light processor top cover

2. Take off the cover (2).

8.4 Electrical disconnection

Where to find the connections

When looking from the top side, the connections are situated left and right of the big fan.

The left side are the formatter connections.

The right side are temperature controls, such as Peltier elements, sensors and motor controls for the shutter.

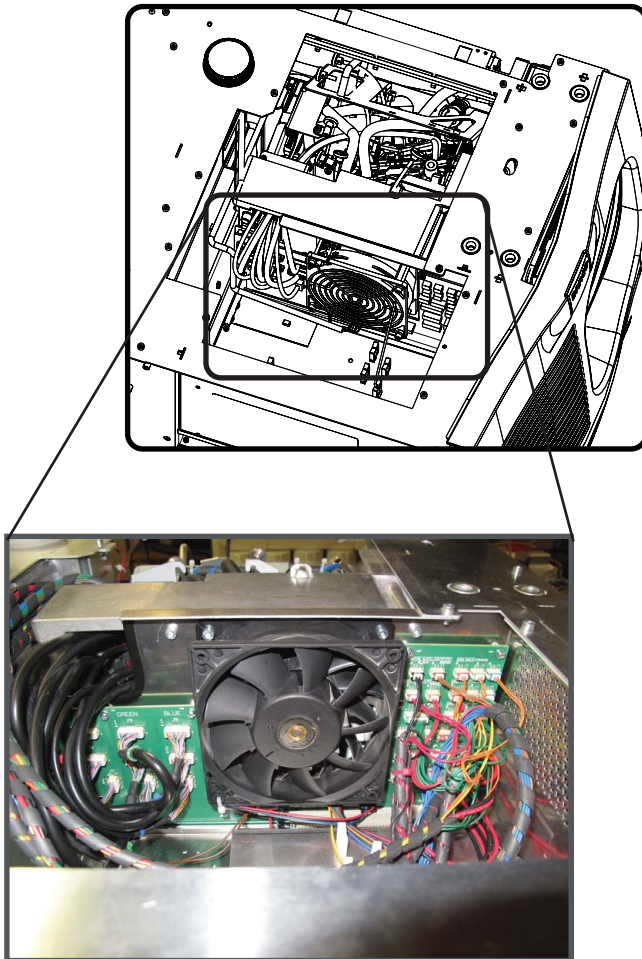

Image 8-5
Light processor cables, connector locations

Where to disconnect

1. Unplug all cables at the right and the left side of the fan.

Caution: The connectors of the formatter cables are with lock mechanism. Push on that the unlock mechanism to pull out the cables.

Note: Do not unplug the connectors just below the fan.

8.5 Light processor assembly removal

Necessary tools

- Flat screw driver 6 x 150 or 10 mm nut driver
- Allen wrench 4 mm

How to remove

1. Remove the lens (see user guide of the projector).
2. Release the two captive screws at the base of the light processor (1 and 2). Use a 6 mm flat screw driver on a 10 mm nut driver.

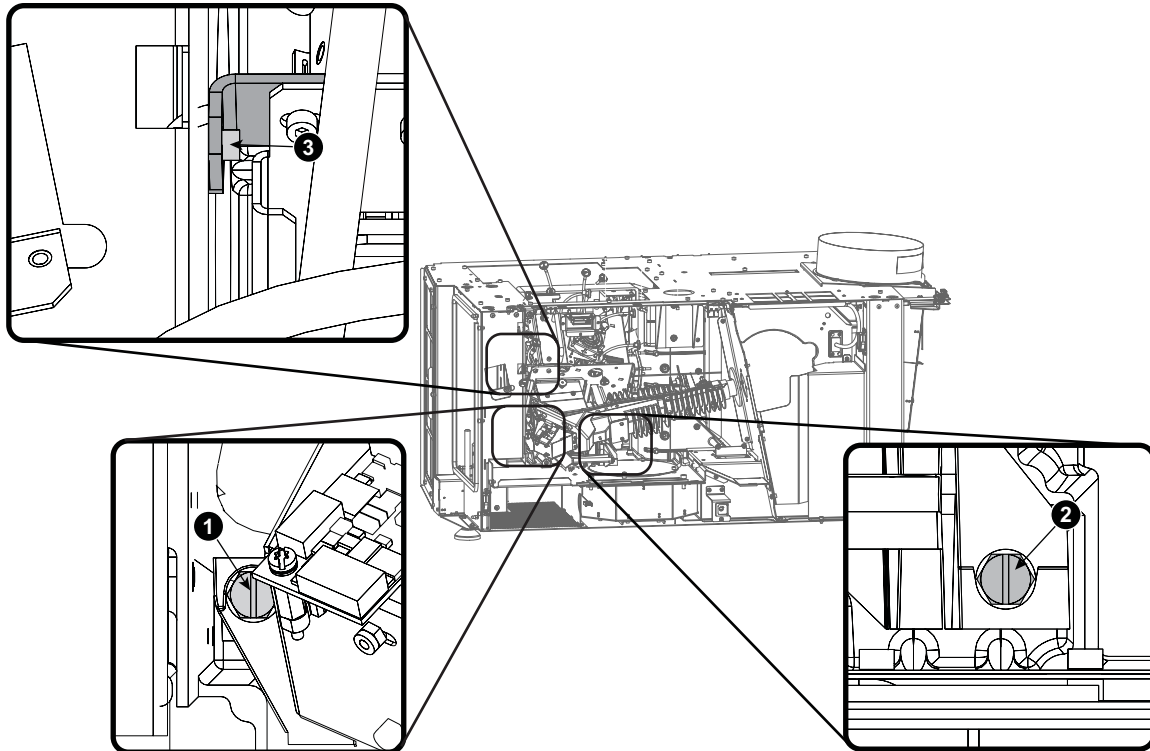

Image 8-6
Light processor fixations

3. Turn out the hexagon head screw at the left side of the light processor (3).

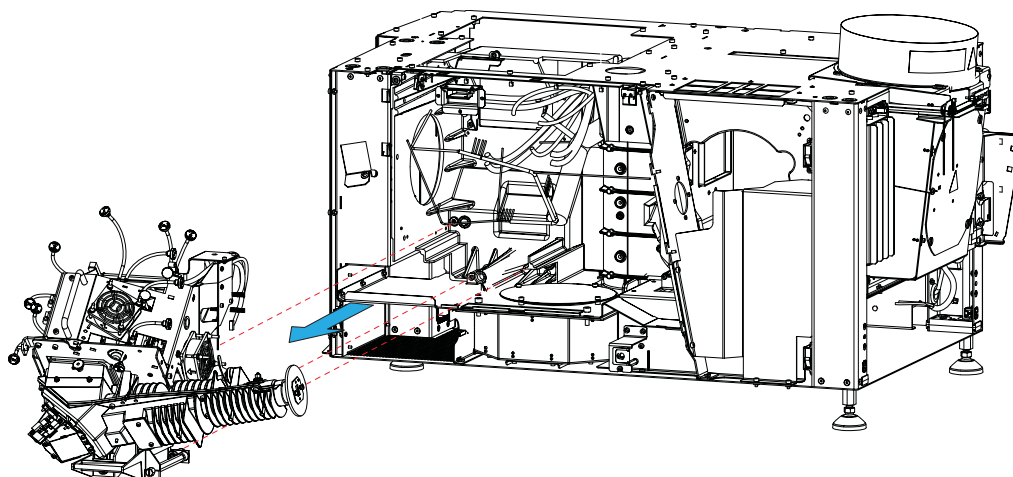

Image 8-7
Light processor removal

4. Take the light processor unit by its handles and gently pull out the light processor assembly of its compartment.
5. Place the light processor assembly on a stable table.

8.6 Preparing the new light processor assembly



Only for a light processor assembly in a flight case.

Necessary tools

Flat screwdriver 8 x 150 mm or 10 mm nut driver

How to remove from the flight case

1. Open all flight case locks and open the flight case.
2. Release the two captive screws at the base of the light processor (1 and 2). Use a 6 mm flat screw driver or a 10 mm nut driver.

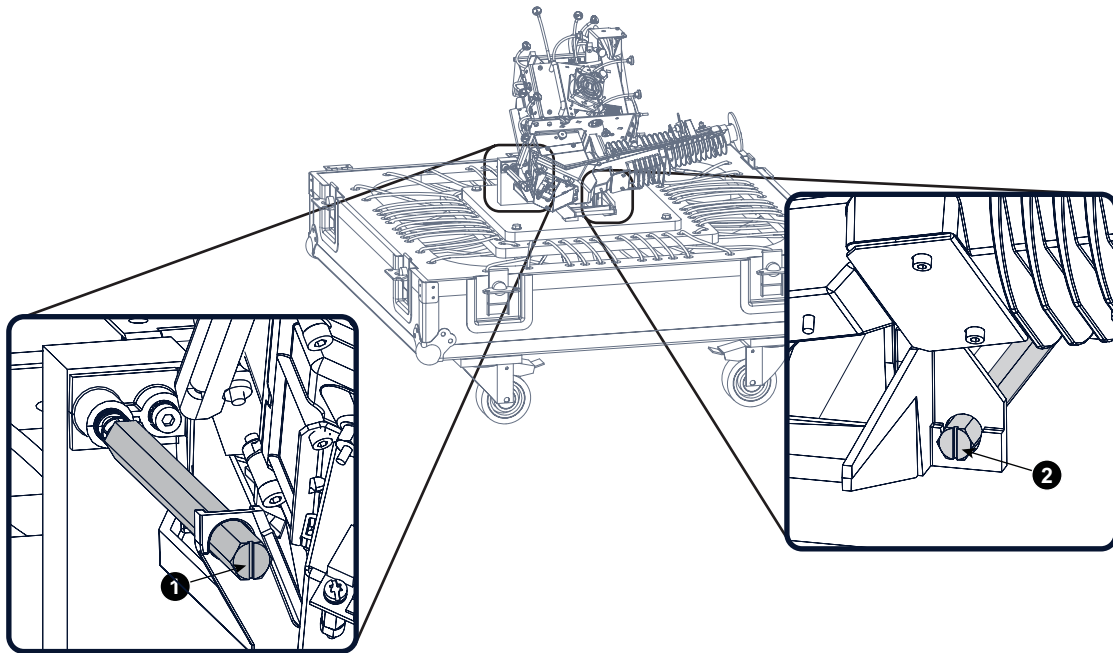

Image 8-8
Light processor assembly fixations

3. Take the light processor assembly by its handles (1 and 2) and slide it forward until the positioning pins are free (A). Then lift it up to remove it from the flight case (B).

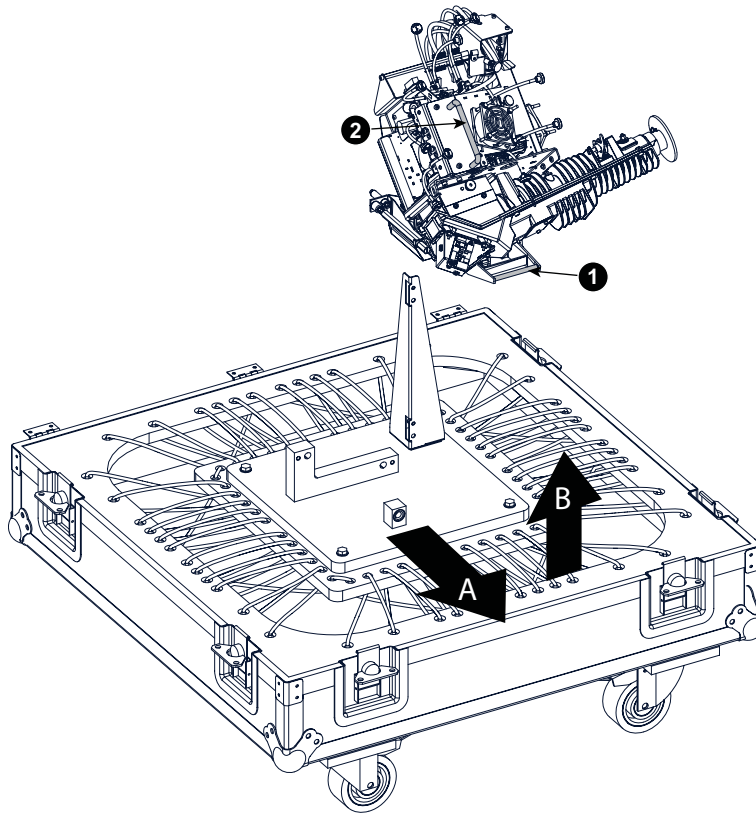

Image 8-9
Remove light processor assembly



The flight case must be reused to send back the removed light processor assembly.

8.7 Installation of the light processor assembly



After installing a new Light Processor, the LUT-SCC file of the new Light Processor has to be installed and activated. See chapter "Spatial Color Calibration (LUT-SCC)", page 157.

Necessary tools

- Flat screw driver 8 x 150
- Allen wrench 4 mm

How to install

1. Make sure there is no lens mounted.
2. Check if the corner bracket is mounted on the new assembly. If not yet mounted, remove the corner bracket of the removed assembly and mount it on the new one.

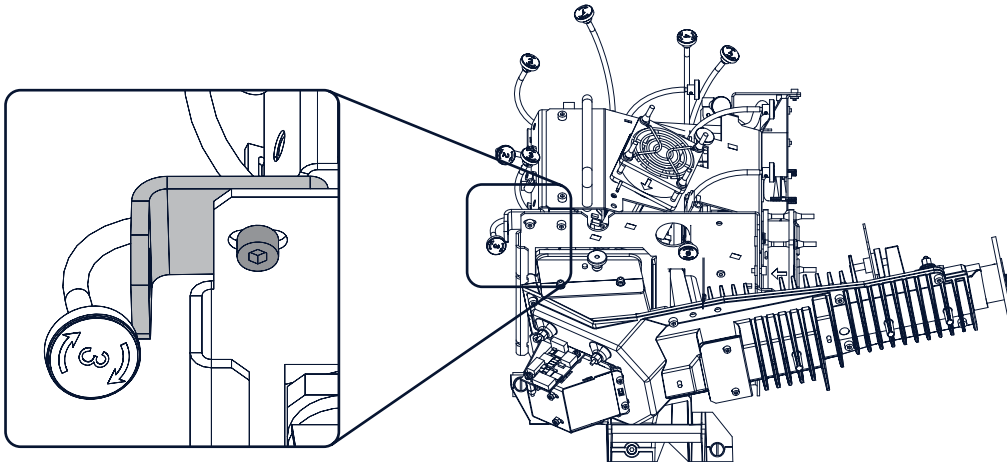

Image 8-10
Corner bracket light processor assembly

3. Take the light processor assembly by its handles and gently slide in the assembly into the compartment of the projector. Make sure that the positioning pins (P) at the backside of the assembly match the positioning holes (H) in the projector.
Note: While inserting the assembly, guide the cables to the back plane side.

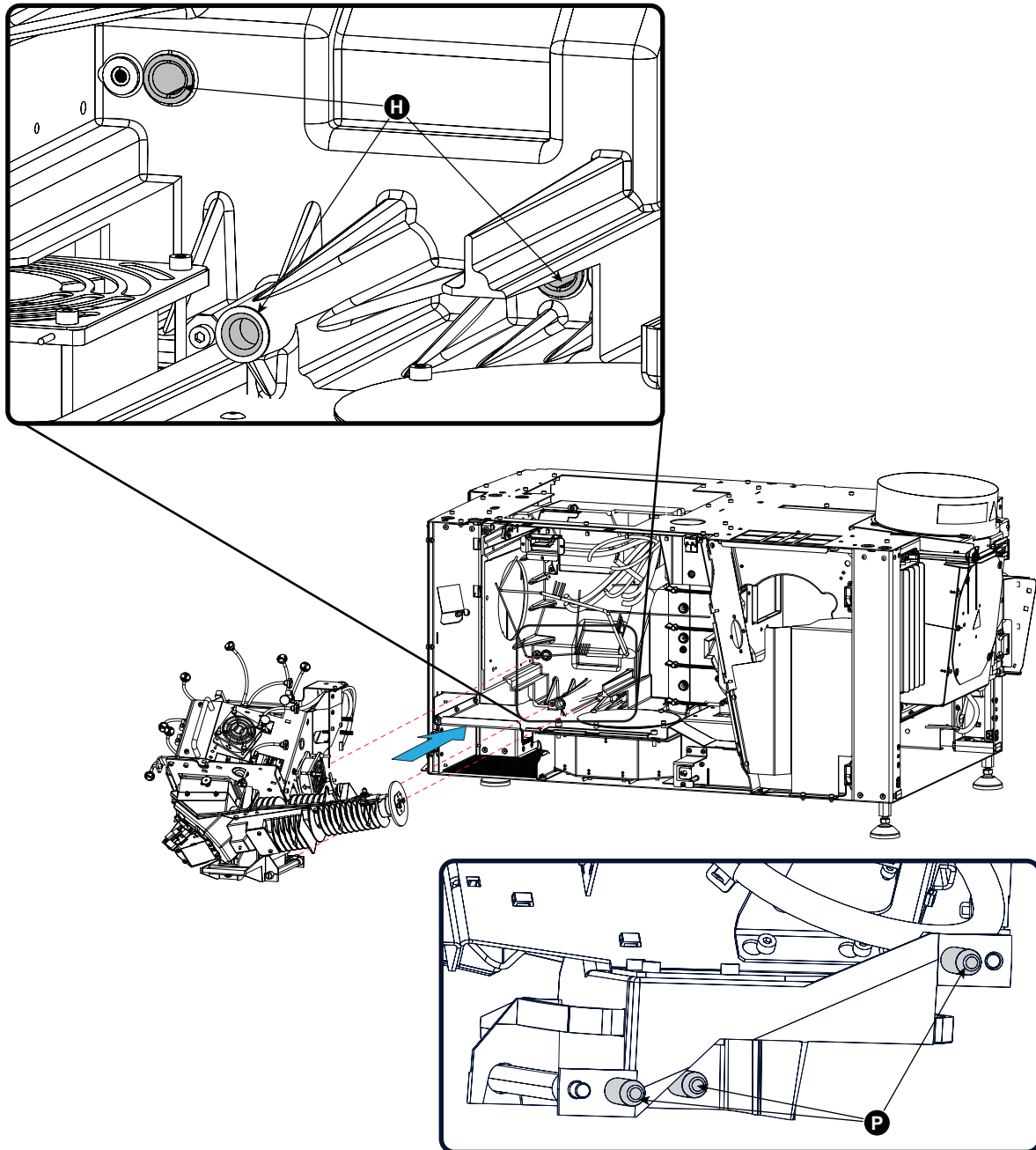

Image 8-11
Light processor installation

4. Secure the light processor assembly by fastening both captive screws (1 & 2).
5. Fixate the corner bracket to the projector frame with an hexagon head screw (3).

8.8 Electrical connections

Preparations

Guide all cables to the connector side of the backplane.

Formatter connections

All formatter cables, data and power, have a colored cable tie. There are 2 cables per color available, both with a different connector. The color name is screen on the printed circuit board. Plug in the cable with e.g. a red cable tie into the connector with the same size and with the indication red. Repeat for all other cables.

Other connections (right side)

Color convention for the connections.

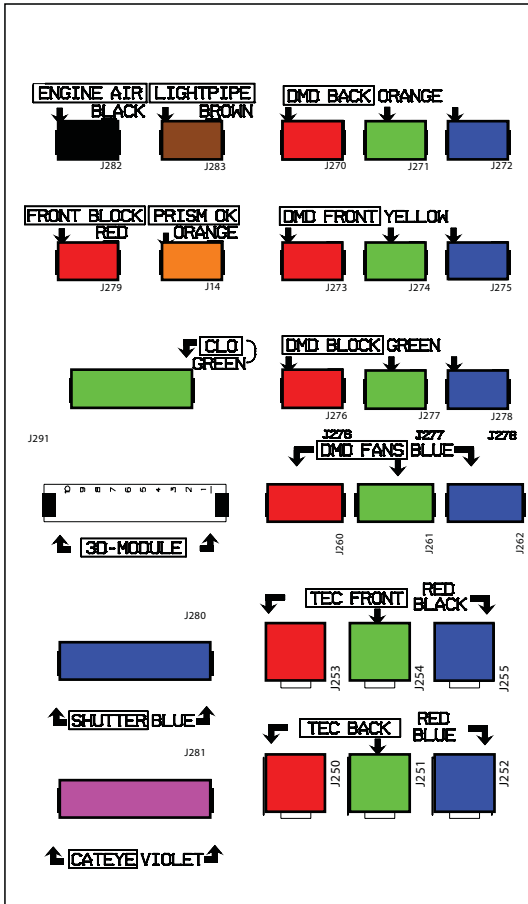

Image 8-12
Color coding cables

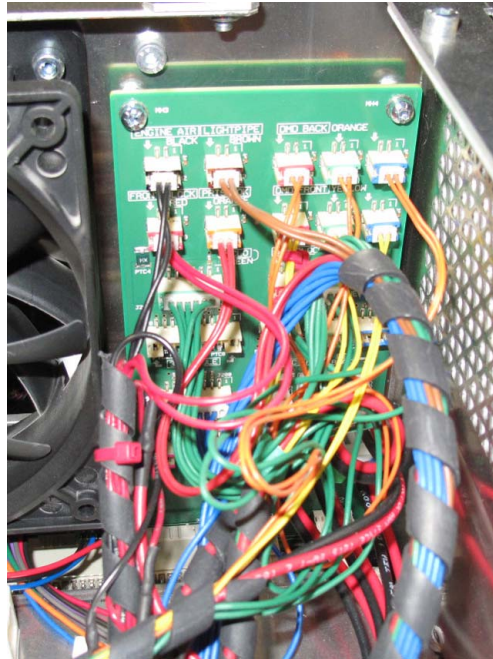

Image 8-13
Color coding cables, image

The color indication on the socket corresponds with the colored cable tie on the cable next to the connector.
The screened color indication just above the sockets corresponds with the color of the wires in the cable tree.

8.9 Mount light processor cover

Necessary tools

No tools.

How to mount

1. Place the cover on top of the projector (1) so that the hooks (H) on both sides match with the holes (F).

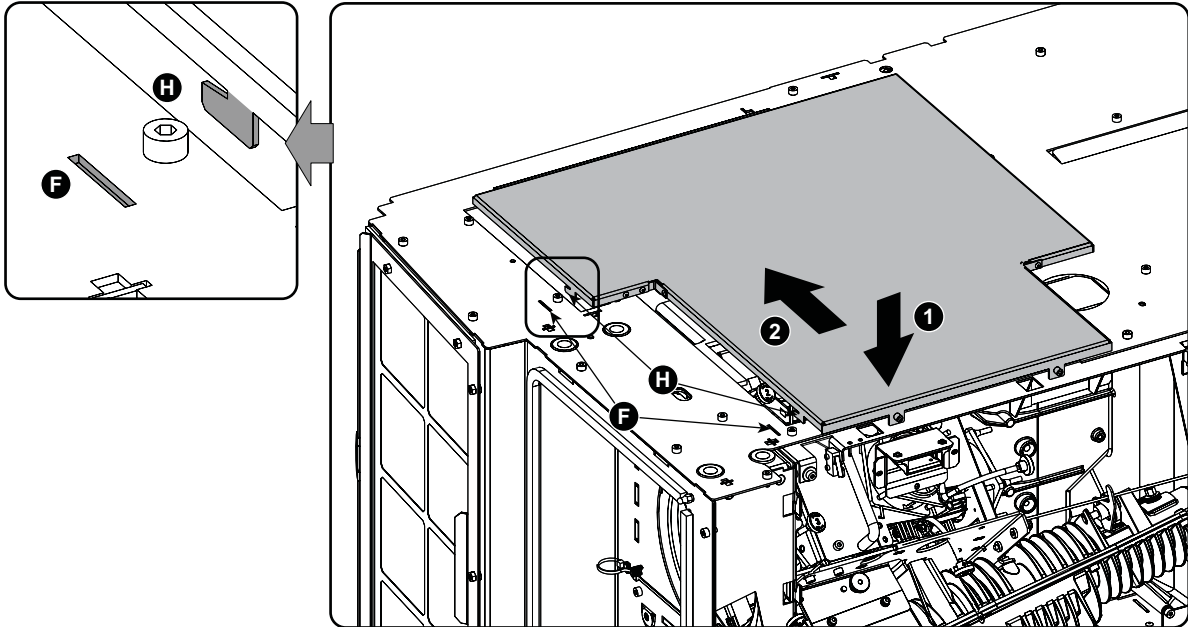

Image 8-14
Light processor top cover

2. Slide the cover backwards until the hooks slide under the top frame (2).

8.10 Mount light processor assembly into the flight case



Only for a light processor assembly in a flight case.

Necessary tools

Flat screwdriver 8 x 150 mm or 10 mm nut driver.

How to mount

1. Take the assembly by both handles (1 & 2) and place the assembly on the springy plate.

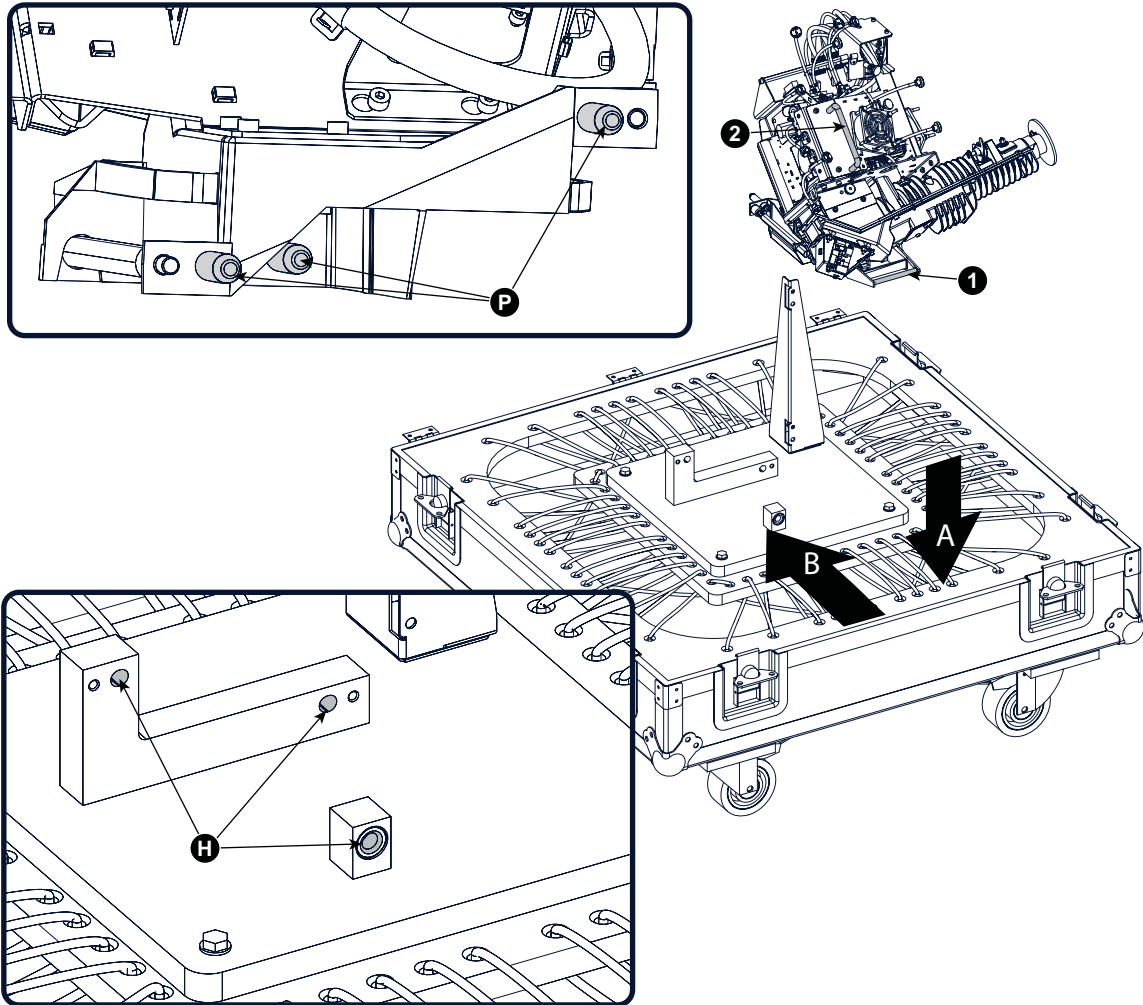

Image 8-15
Mount assembly in flight case

2. Slide the assembly on its position so that the positioning pins (P) of the assembly match into the positioning holes (H).
3. Secure by fastening both captive screws.

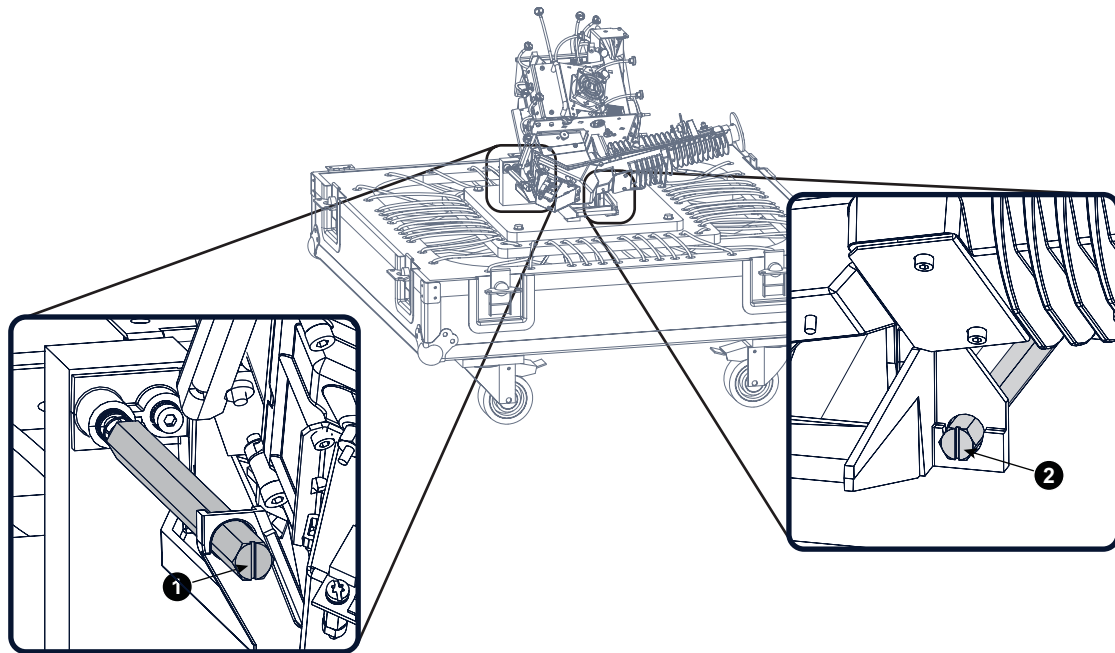

Image 8-16
Secure light processor assembly

4. Close the flight case and lock the locks.

8.11 Finalize the installation of the light processor assembly

Execute the following steps :

1. Close the sealed compartment, "Close the sealed compartment", page 86.
2. Install the top cover, "Installation of the top cover", page 87.
3. Install the side cover, "Installation of the side cover", page 89.
4. Clear the security warning due to opening the sealed compartment.

8.12 Replacement of the Light Sensor Module

Purpose of the Light Sensor in the Light Pipe

To obtain a Constant Light Output (CLO) from the projector a light sensor is mounted just behind the fold mirror. On a regular base the controller of the projector read the measured values of this light sensor and, if required, sends corrective information to the Lamp Power Supply (LPS).



The left cover has to be removed from the projector to replace the Light Sensor Module. This procedure assumes that the left cover is already removed from the projector.

Necessary tools

- TX10 Torx screw driver.
- Light meter.

How to replace the Light Sensor Module of the Light Processor

1. Disconnect the wire unit from the Light Sensor Module.

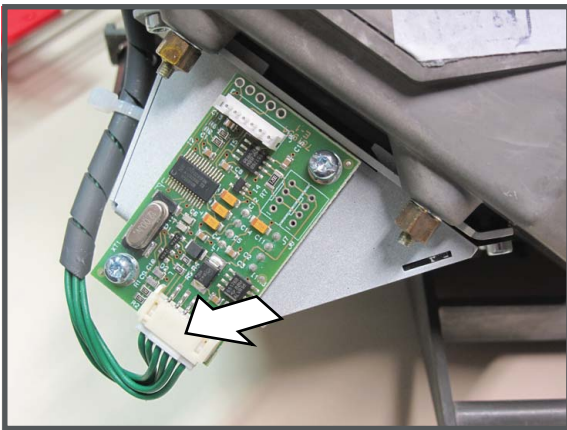

Image 8-17
Light sensor connection

2. Remove the Light Sensor Module by releasing the two Torx screws (reference 1). Use a TX10 Torx screw driver.

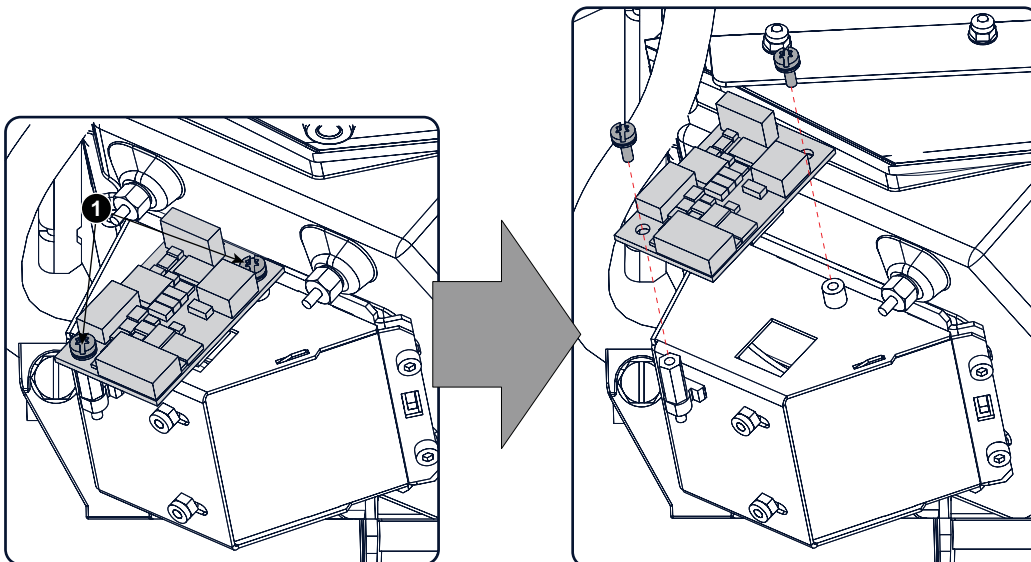

Image 8-18
Light sensor unit removal

3. Install a new Light Sensor Module. Use a TX10 Torx screw driver to fasten both screws (reference 1).
4. Reconnect the wire unit with Light Info Module (image 8-17).
5. Place a light meter in the center of the screen and calibrate the Light Sensor Module. For detailed instructions see user guide of the Communicator software.

8.13 Replacement of the dowser (shutter)

Dowser assembly

The dowser or shutter ("dowser" is more common in the cinema market and "shutter" in the events market) of the projector is mounted upon the Light Processor just above the light output path of the prism. The dowser assembly has an "open" and a "close" state. In the "close" state the dowser blade shuts off the light beam between the Light Processor (DMD's) and lens. In the "open" state, the dowser is retracted from the light beam. Note that the local keypad has a dedicated button "DOWSER" to operate the dowser.



The Light Processor has to be removed from the projector before replacing the dowser. This procedure assumes that the Light Processor is already removed from the projector.

Necessary tools

2,5 mm Allen wrench.

How to replace the dowser of the Light Processor

1. Disconnect the wire unit of the dowser.

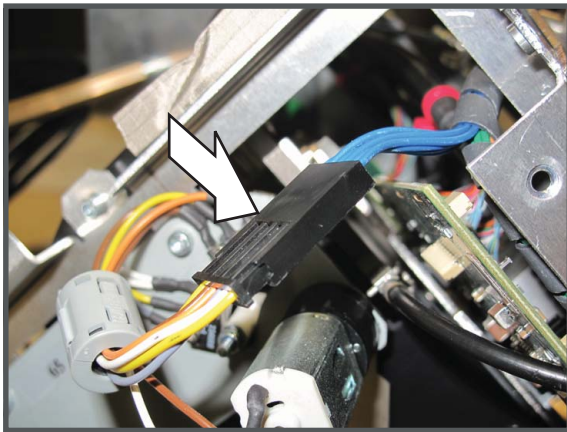

Image 8-19
Dowser connection

2. Remove the dowser assembly from the Light Processor by releasing both hexagon socket head cap screws (reference 1) as illustrated. Use a 2,5 mm Allen wrench.

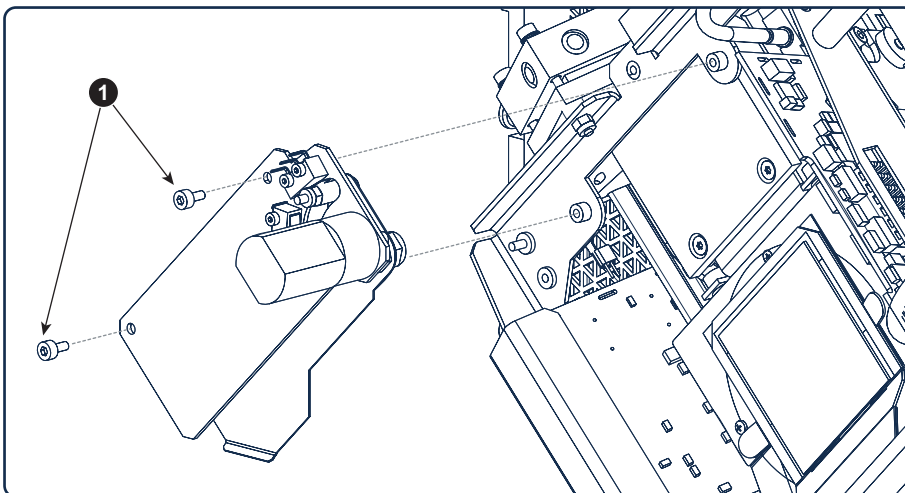

Image 8-20
Remove fixation screws

3. Place a new dowser assembly in position and fasten with two hexagon socket head cap screws (reference 1). Use a 2,5 mm Allen wrench.

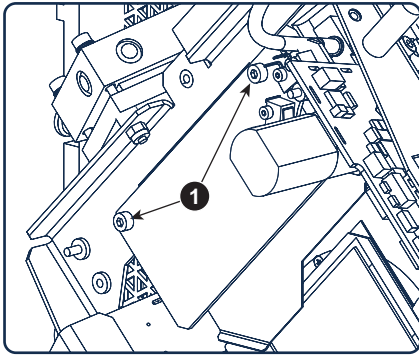

Image 8-21
Mount new dowser

4. Reconnect the wire unit of the dowser image 8-19.

8.14 Adjusting the notch filter

Purpose of the notch filter

The notch filter is a coated glass plate located at the end of the light pipe assembly. The notch filter applies some small color corrections of the light coming out of the light pipe, which is emitted by the xenon lamp of the projector. This is done to achieve an optimal color calibration of the native colors. The notch filter can slightly turn, with respect to the light path, which allows a small adjustment of the native colors. Note that, next to the pure optical color calibration by the notch filter, there is also a software color calibration.

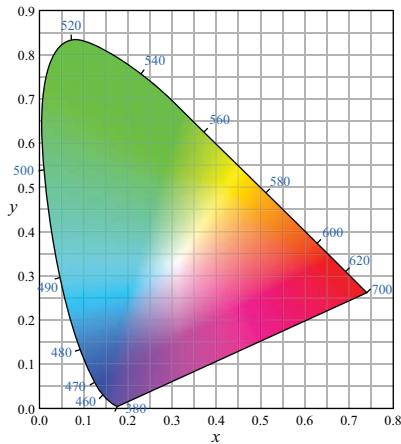

Image 8-22
Color gamut.

Target range for x, y Chroma values

- **Uncorrected GREEN:** (changes together with red)
 - x : 0.245 – 0.285
 - y : 0.67 – 0.71
- **Uncorrected RED:** (changes together with green)
 - x : 0.67 – 0.69
 - y : 0.31 – 0.33
- **Uncorrected BLUE:** (no impact)
 - x : 0.12 – 0.16
 - y : 0.02 – 0.8



To access the notch filter, the left side cover has to be removed from the projector. This procedure assumes that the left side cover is already removed from the projector.

Necessary tools

No tools.

How to adjust the notch filter

1. Release the Thumb screw (reference 1) of the notch filter.

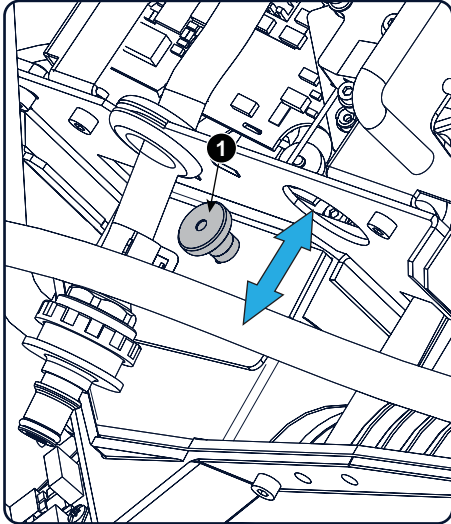

Image 8-23
Notch filter, adjustment button

2. Start up the projector and display an uncorrected red test pattern.
Tip: See user guide of the Communicator software for detail instructions about color calibration
3. Measure the X and Y values of the projected red test pattern. Use for that a colorimeter. Make sure that the red test pattern is uncorrected.
4. Slightly move the adjustment button up or down until the measured X and Y values are within the required specs. (See above)
Note: The adjustment range of the notch filter is limited. For most projectors the mid position gives also the most optimal result.
5. Fasten the thumb screw again (reference 1), to secure the position of the notch filter. Make sure that the position of the notch filter remains unchanged while fastening the thumb screw.

8.15 Cleaning the Prism exit side

When should one clean the Prism exit side?

Clean the Prism exit on a regular basis to maintain light output level.



This procedure requires that the lens is removed from the projector.

Necessary tools

- Compressed air.
- Clean Toraysee® cloth or any micro fiber lens cleaning cloth.

Necessary parts

Lens cleaner (e.g. Carl Zeiss lens cleaner or Purasol® or any waterbased lens cleaner)

How to clean the Prism exit side?

1. Wipe off the dust of the Prism exit. Use for that a clean Lens cleaning cloth.
Tip: *Limit the number of wipe movements. This to protect the optical coating. It is better to wipe off the dust with one good wipe movement than with 10 soft wipe movements.*
2. Is all dust removed from the Prism exit?
If yes, stop this cleaning procedure.
If no, wipe off the dust of the Prism exit with a clean lens cleaning cloth and lens cleaner.

9. SPATIAL COLOR CALIBRATION (LUT-SCC)

About this chapter

This chapter explains how to obtain the correct LUT-SCC file and how to install it after having replaced the Light Processor or ICMP/ICP board.

Overview

- Introduction to SCC file
- Obtain the Serial Number of the installed Light Processor
- Download the LUT-SCC file from the Barco website
- Upload Spatial Color Calibration file
- Activate Spatial Color Calibration file

9.1 Introduction to SCC file

Introduction

Barco has introduced the Spatial Color Calibration (SCC) file on the DP2K-12C/11CX digital projectors. The SCC file contains information to improve the color uniformity of the image. The uniformity is measured in the factory and stored in a LUT-SCC file on the ICP board. This LUT-SCC file is activated on the projector at factory.

Impact on service

As the LUT-SCC file is Light Processor specific, when replacing the **Light Processor** of the projector a **new LUT-SCC file** has to be uploaded and set as active file. As the LUT-SCC file is stored on the Integrated Cinema Processor (located on the **ICMP or ICP** board) the **LUT-SCC file** should be uploaded and activated after replacement of the ICMP or ICP board.

This chapter explains how to obtain the correct LUT-SCC file and how to install it after having replaced the Light Processor or ICMP/ICP.



Communicator version 4.7.8 ⁽¹⁾ or later is required to activate LUT-SCC files.

1. For DP4K-P and DP2K-S the SCC functionality is already incorporate in the Communicator version 4.7.3

9.2 Obtain the Serial Number of the installed Light Processor



The Serial Number of the installed Light Processor can be obtained in two different ways. Either by reading it from the label on site or by reading it remotely using the Communicator software.

How to obtain the Serial Number of the installed Light Processor remotely?

1. Start up the Communicator software version 4.7.9 ⁽²⁾ or later.
Note: The DP2K/DP4K software package version 1.11 ⁽³⁾ or later must be installed to read out the Light Processor serial via the Communicator.
2. Create a Diagnostic Package of the projector. For detailed instructions see User Guide of the Communicator chapter "Diagnostic Package".
3. Open the Diagnostic Package using Windows Explorer or the 'Diagnostic Package Reader' included in the PC version of the Communicator software.
4. Look in the file/section "Hardware Info" for the serial number of the Light Processor.
Note: Only for recent Light Processors the serial number will be available in the Diagnostic Package. For older Light Processors the serial number has to be read from the label (see below).

How to obtain the Serial Number of the installed Light Processor on site?

1. Remove the Lens from the projector.
2. Write down the Serial Number of the Light Processor. The label with Serial Number of the Light Processor (reference 1 image 9-1) is visible through the Lens Holder opening. The label is located at the front base of the Light Processor.



Image 9-1
Location label with Serial Number of the Light Processor of a DP4K-P projector.



The position of the label with Serial Number of the Light Processor may be slightly different. However, it will always be located at the front base of the Light Processor.

2. For DP4K-P and DP2K-S the SCC functionality is already incorporate in the Communicator version 4.7.3
 3. For DP4K-P and DP2K-S the SCC functionality is already incorporate in the DP2K/DP4K software package version 1.09.104

9.3 Download the LUT-SCC file from the Barco website



A logon ID is required to access the secured zone myBarco on the Barco website <https://www.barco.com>. A logon ID for the secured zone can be requested at the portal page of the Barco website.

Necessary parts

Serial Number of the installed Light Processor.

How to download the Spatial Color Calibration file (LUT-SCC) from the secured Barco website?

1. Open the url: <https://www.barco.com> in a web browser.
2. Login into the secured Barco website.



Image 9-2

Or,
in case you are already logged in, click on your login name and select "My support section".

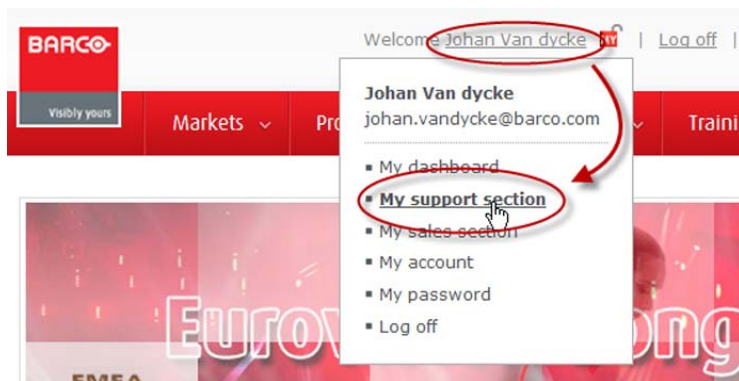

Image 9-3

3. Navigate in the **My Support** section at the left side to **Digital Cinema > Spatial color corrections**.
4. Fill in the Serial Number of the Light Processor and press the "Search file" button.

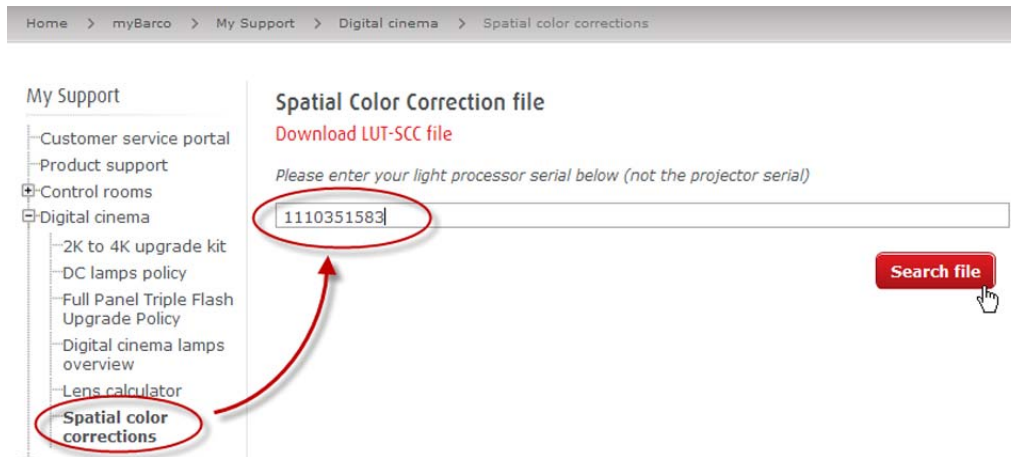

Image 9-4

If a LUT-SCC file is found a download link will appear. Proceed with the next step.

In case no LUT-SCC file is found end this procedure and use the default LUT-SCC file which is already installed on the ICP board. For 2K projectors this is "ones2K_LE", for 4K projectors this is "ones4K_LE".

5. Click on the LUT-SCC download file.

Color file overview

| | |
|--------------------|------------------------------------|
| Serial number | 1110351583 |
| Last time modified | 05/02/2013 |
| Download file | 1110351583.LUT-SCC |

Image 9-5

9.4 Upload Spatial Color Calibration file



When replacing the Light Processor a new LUT-SCC file should be downloaded from the secured Barco website.

When replacing the ICP board the LUT-SCC file should be available if the projector files were backed up properly. If not, the LUT-SCC file can also be downloaded from the secured Barco website using the serial number of the installed Light Processor.

For detailed instructions see procedures "Obtain the Serial Number of the installed Light Processor", page 159, and "Download the LUT-SCC file from the Barco website", page 160.

Necessary tools

Communicator software version 4.7.9 (or later)

Necessary parts

- Serial Number of the installed Light Processor.
- LUT-SCC file available on the PC of the Communicator or on USB-stick when using the Communicator Touch Panel.

How to upload the LUT-SCC file into the projector?

1. Start up the projector and the Communicator (version 4.7.9 ⁽⁴⁾ or later).
2. Ensure that the projector is connected with the Communicator. Either via a direct connection or via network. For detailed instructions see User Guide of the Communicator (manual version 07).
3. Go to the File manager of the Communicator.
4. Click on the drop down box in *Local files* (1) and browse to the LUT-SCC file to be uploaded (2).

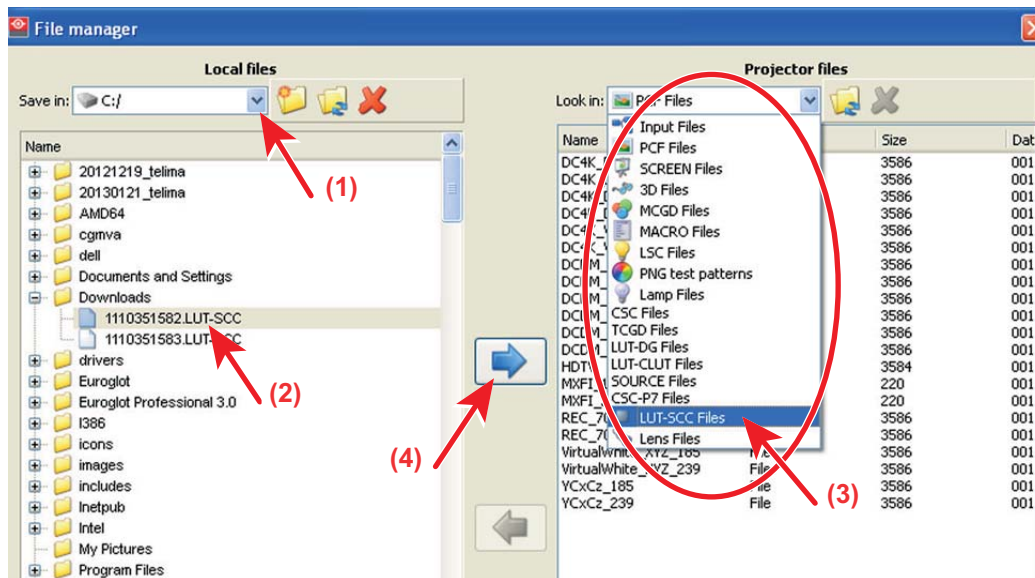

Image 9-6

5. Click on the drop down box in *Projector files* and select the file type LUT-SCC (3).
6. Click on the arrow pointing to the right (4).

The file is uploaded from its original location to the projector file system.

4. For DP4K-P and DP2K-S the SCC functionality is already incorporate in the Communicator version 4.7.3

9.5 Activate Spatial Color Calibration file

Necessary tools

Communicator software version 4.7.9 (or later)

How to activate the LUT-SCC file?

1. Open the *File manager* in the Communicator and select in the drop down box of *Projector files* the file type LUT-SCC (1).
2. Select the desired LUT-SCC file from the list (2).
3. Click **Select active** (3).

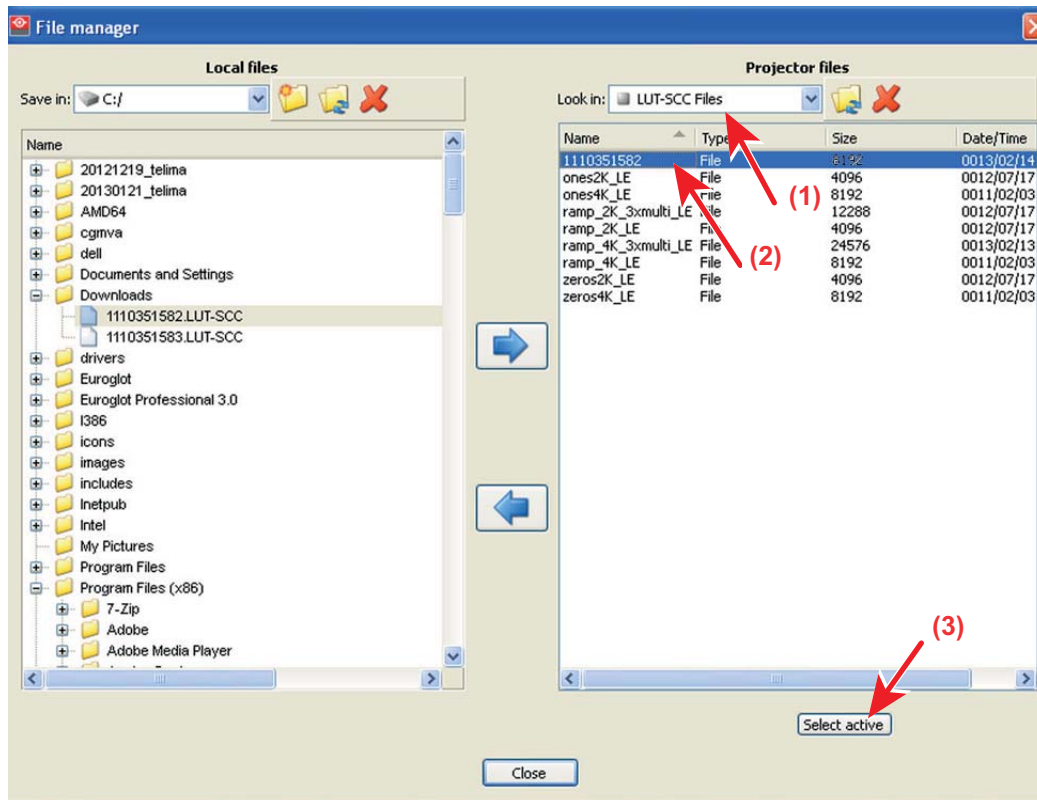

Image 9-7

4. Click on **Close** to exit the File manager.



In case no Light Processor serial LUT-SCC file is available use the default LUT-SCC file which is factory installed on the ICP board and thus displayed in the list. For 2K projectors this is "ones2K_LE", for 4K projectors this is "ones4K_LE".

10. CONVERGENCE

About this chapter

This chapter describes how to prepare the projector for convergence adjustment and how to adjust the convergence.

10.1 Convergence controls

Extended control knobs

As the DMD of the blue channel is not accessible in the projector, the image of this DMD will be taken as reference. Red and green will be aligned on blue when a small convergence drift is recognized. So, the DMD of the blue channel is fixed and can not be adjusted. The red and green channel is equipped with three extended control knobs for convergence adjustment. The adjustment knobs are numbered from 1 to 6 and have the same color as the channel which they effect (1, 2 and 3 for red and 4, 5 and 6 for green).

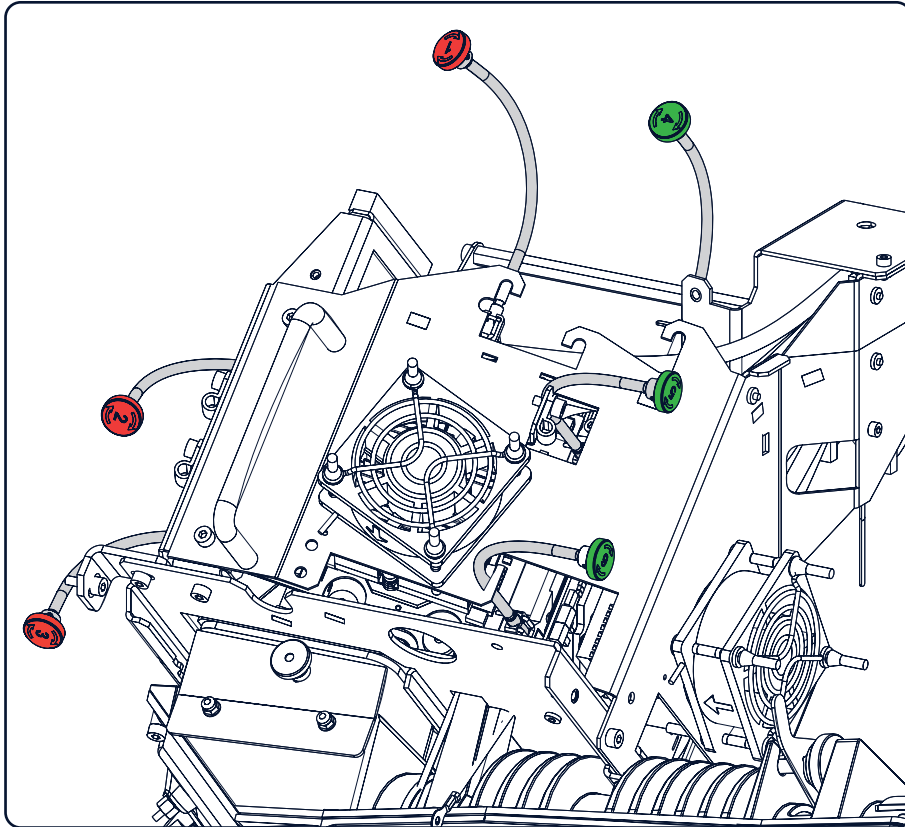

Image 10-1
Convergence knobs

- 1 Red channel, knob number 1
- 2 Red channel, knob number 2
- 3 Red channel, knob number 3
- 4 Green channel, knob number 4
- 5 Green channel, knob number 5
- 6 Green channel, knob number 6

Convergence test pattern

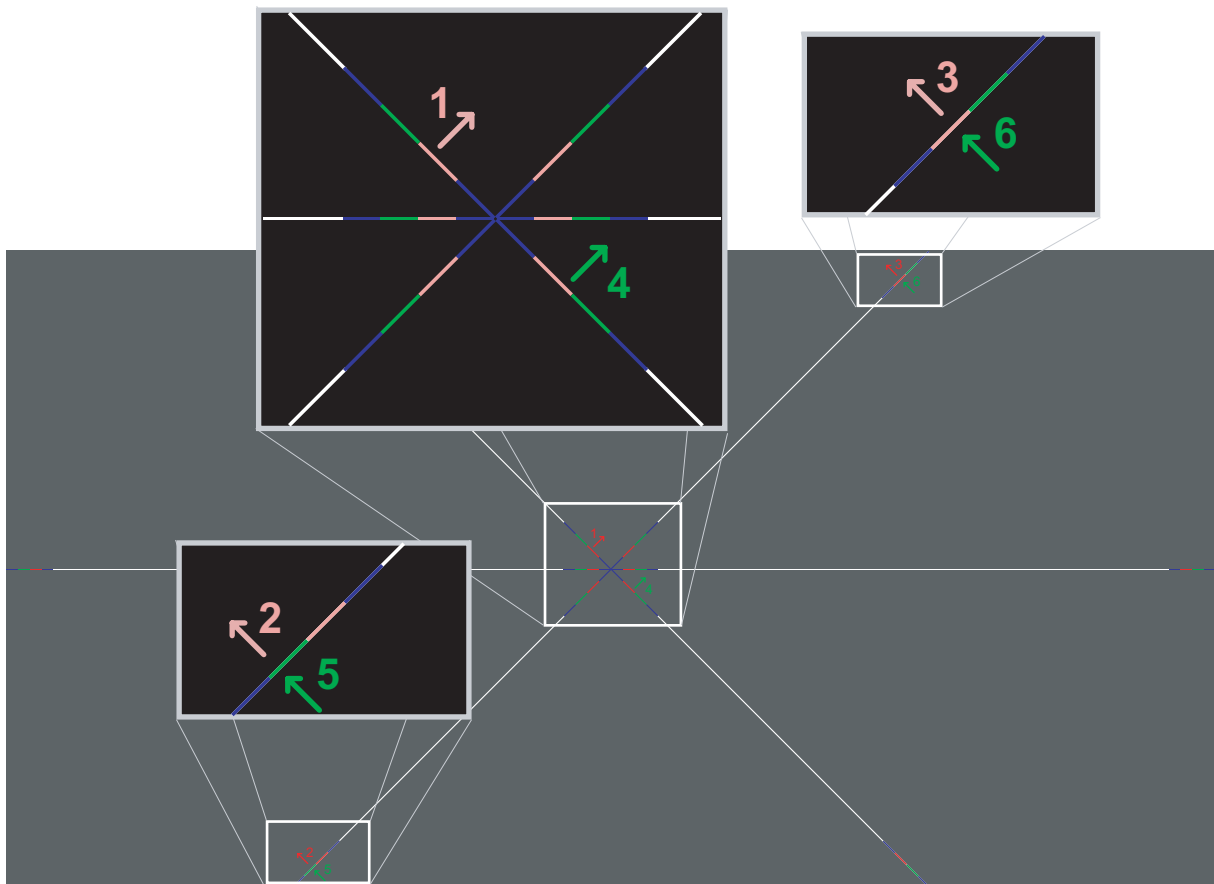

Image 10-2
Convergence test pattern

The test pattern illustrated above is specially designed for convergence purposes. The test pattern has three red arrows numbered from 1 to 3 and three green arrows numbered from 4 to 6. These numbers and colors correspond with the numbers and colors of the extended control knobs (image 10-1). The direction of the arrow shows the movement of the channel color (red or green) when turning the corresponding knob in the direction indicated by the arrow marked on the knob.



The three convergence control knobs of one channel stand in relation with each other. So, a change to one of them will also effect the adjustment results of the two others. Therefore, all three control knobs have to be alternately and repeatedly adjusted until the projected color is perfectly converged with the blue reference color of the test pattern.

Adjustment range

- The adjustment range is limited to approximately 30 pixels in both directions.
- One turn (360°) of a control knob relates to an approximately 30 pixel displacement on the screen.
- When changing the adjustment direction there will be some play of approximately one turn (360°).

10.2 Preparing the convergence adjustment

Necessary tools

Flat blade screwdriver

Prepare projector for convergence adjustment

1. Remove all side covers and top cover of the projector, see "Removal and installation of projector covers", page 77.
2. Open the sealed compartment of the light processor, see "Open the sealed compartment", page 85.
3. Remove the convergence cover plate as follow:
 - a) Loosen both screws (reference 1 and 2).
 - b) Slide the plate forwards until all hooks at both sides of the plate become free.
 - c) Take off the plate.

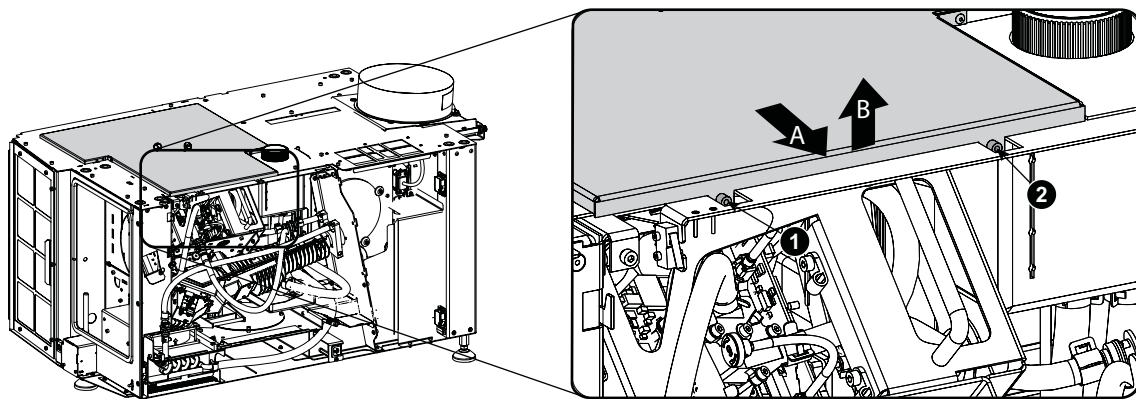

Image 10-3
Convergence cover plate

4. Reinstall the lens and start up the projector.
5. Use the Communicator software to activate the convergence test pattern.



Image 10-4
Convergence test pattern

10.3 Red on Blue convergence



This procedure can only be executed when all preparations are taken to converge the image.

Necessary tools

No tools.

How to converge

1. Slightly turn the red colored control knob number 1 until the red pattern in the center of the projected image converges with the blue pattern. Note that a turn of a few degrees corresponds with one full pixel.

Note: When start turning the knob, a little resistance can be felt. This resistance is part of the internal locking mechanism of the adjustment.

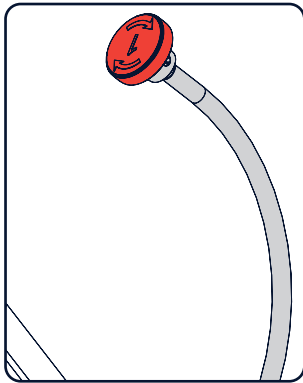
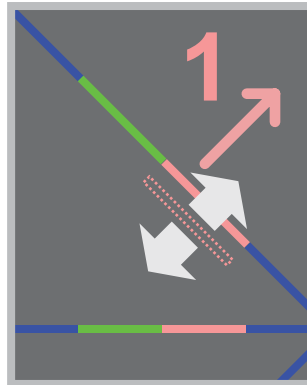
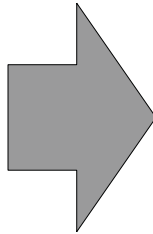

Image 10-5
Clockwise turning will move line downwards.



2. Slightly turn the red colored control knob number 2 until the red pattern in the lower left of the projected image converges with the blue pattern.

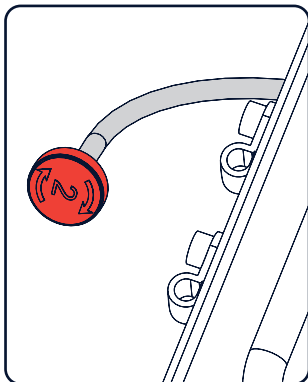
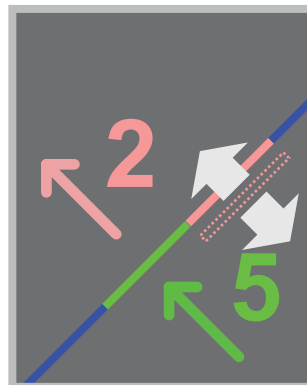
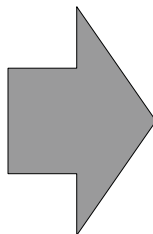

Image 10-6
Clockwise turning will move line upwards.



3. Slightly turn the red colored control knob number 3 until the red pattern in the upper right of the projected image converges with the blue pattern.

10. Convergence

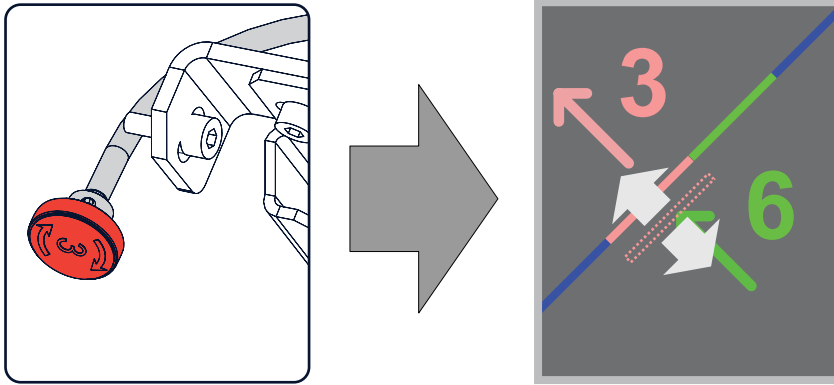

Image 10-7
Clockwise turning will move line upwards.

4. Repeat step 2 and step 3 until coincidence is obtained of the red pattern in the lower left and upper right of the projected image.
5. Repeat from step 1 until full coincidence is obtained of the red pattern in the center, lower left and upper right of the projected image.

10.4 Green on Blue convergence



This procedure can only be executed when all preparations are taken to converge the image.

Necessary tools

No tools.

How to converge

1. Slightly turn the green colored control knob number 4 until the green pattern in the center of the projected image converges with the blue pattern. Note that a turn of a few degrees corresponds with one full pixel.

Note: When start turning the knob, a little resistance can be felt. This resistance is part of the internal locking mechanism of the adjustment.

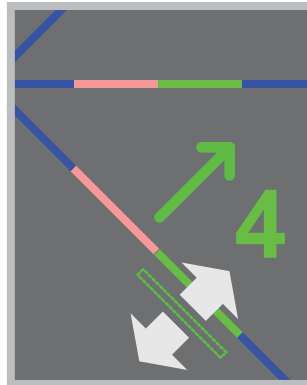
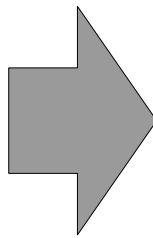
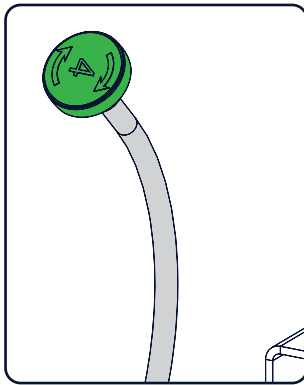

Image 10-8
Clockwise turning will move the line downwards.

2. Slightly turn the green colored control knob number 5 until the green pattern in the lower left of the projected image converges with the blue pattern.

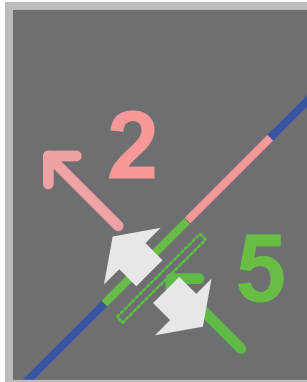
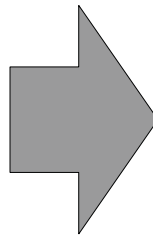
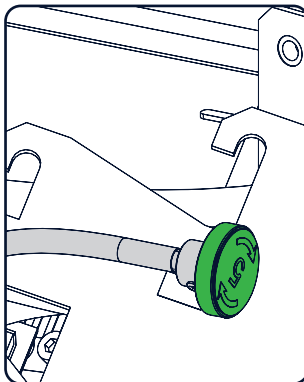

Image 10-9
Clockwise turning will move the line upwards.

3. Slightly turn the green colored control knob number 6 until the green pattern in the upper right of the projected image converges with the blue pattern.

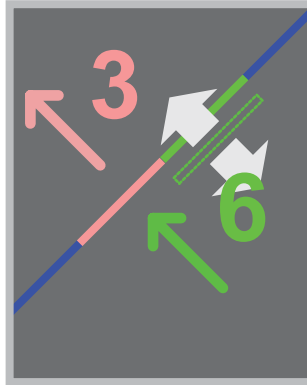
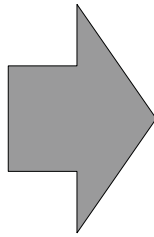
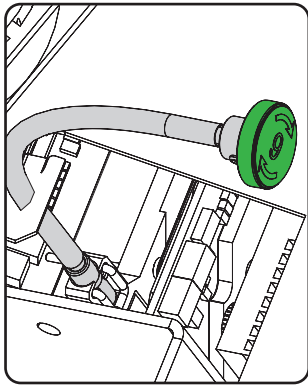

Image 10-10
Clockwise turning will move the line upwards.

4. Repeat step 2 and step 3 until coincidence is obtained of the green pattern in the lower left and upper right of the projected image.
5. Repeat from step 1 until full coincidence is obtained of the green pattern in the center, lower left and upper right of the projected image.
6. Close the sealed compartment and reinstall all covers of the projector.

11. INTEGRATOR ROD

About this chapter

Overview

- Introduction
- Rod diagnostic
- Removal of the integrator rod
- Installation of a new integrator rod
- Adjusting the integrator rod

11.1 Introduction

Functionality of the integrator rod

The integrator rod is made of fused silica. The cross-section of the rod has the same aspect ratio as the active surface of the DMD's used in the light processor. The function of the integrator rod is to match the shape of the light path to the shape of the DMD's and to neutralize the hot spot effect caused by the light source. Furthermore, the integration rod ensures that the light beam is focused on the DMD's, which results in an optimally focused light beam on the screen.

The integrator rod is located at the entrance of the light pipe. The light emitted by the lamp is reflected via the "cold mirror" into the rod, which integrates the incoming light into a homogeneous rectangle shaped beam of light.

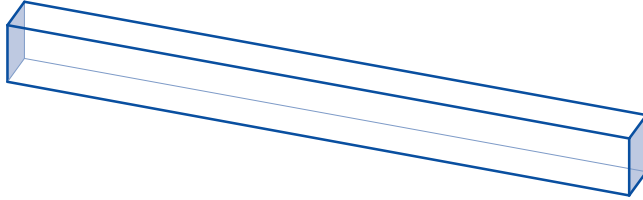

Image 11-1

The entrance and exit side of the integrator rod are coated to achieve optimal performance. Clearly the rod may never be contaminated with grease, dirt, liquid or the such. for optimal protection the rod is mounted inside an aluminium tube, which requires replacing together with the rod. This aluminum tube also contains an adjustment mechanism to position the rod inside the light pipe. The integrator rod, the aluminium tube and the adjustment mechanism together form the "integrator rod assembly".



CAUTION: Use cotton gloves to handle the integrator rod. Greasy fingerprints or other dirt on the integrator rod will burn into the rod and cause permanent damage.

11.2 Rod diagnostic

General

Due to bad environmental conditions the integration rod may become contaminated with grease, dust, dirt or other particles, which will burn into the rod and cause permanent damage. As a result spots may become visible in the projected image on the screen. To confirm that these spots are caused by a damages to the rod please diagnose the rod as described in the following procedure.

How to diagnose the integrator rod of the projector

1. Remove the side cover of the projector.

Caution: Remove the side cover of the projector only in a clean and dust free area. Never remove the side cover in an area which is subject to airborne contaminants such as that produced by smoke machines or similar.

2. Switch on the projector and project a white test pattern. See users manual of the projector to do so. Make sure that the projected white test pattern is focused.
3. Loosen the lock nut on the light pipe (1)

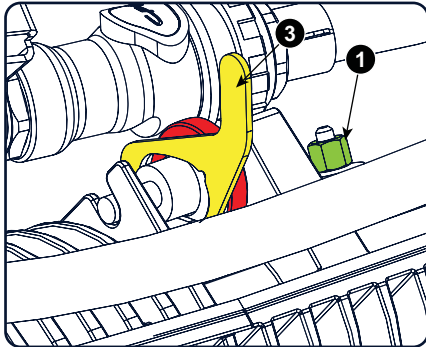

Image 11-2

4. Gently move the handle (3) forward or backward while watching the projected image.
5. Do you see spots in the projected image rotate along with the movements of the rod?
If yes, these spots are caused by damages to the integration rod. Replace the rod assembly.
If no, integration rod is OK. Re-adjust and secure the integration rod and reinstall the side cover of the projector.

11.3 Removal of the integrator rod



To remove the integrator rod from the light pipe the light processor unit has to be removed from the projector first.



CAUTION: All servicing to the Light Processor unit has to be done in a dust free area. Use compressed air to blow away all dust on the outside of the Light Processor unit before entering the unit into the dust free area.

Necessary tools

- Allen wrench 2.5 mm
- Allen wrench 3 mm

How to remove

1. Disconnect the cable of the light sensor unit.

2. Turn out both screws (reference 1) and slide out the eye plate.

Note: Light processor may be placed on the pins and the top of the processor mechanics. without damaging any part inside the assembly.

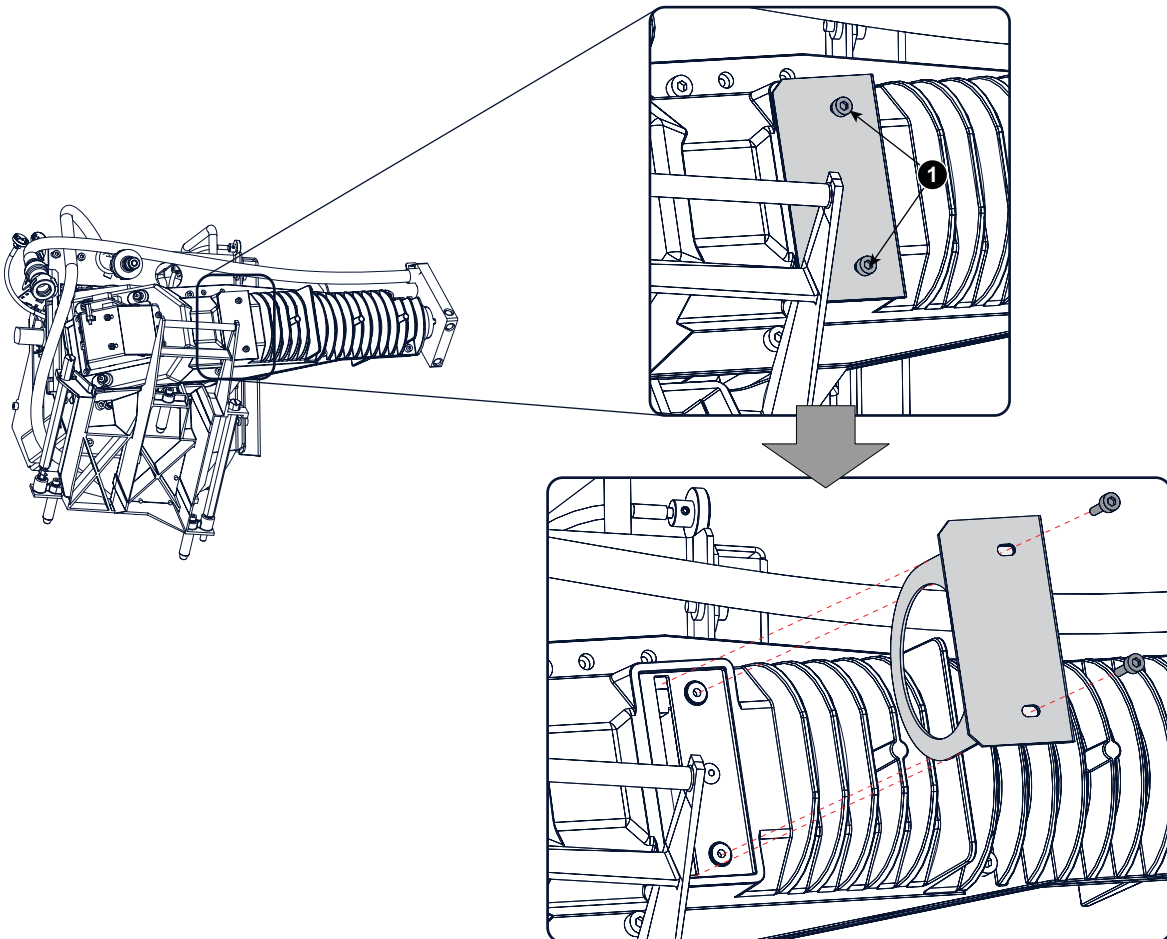

Image 11-3

3. Turn out the screws of the light pipe housing (4 times 2 screws)

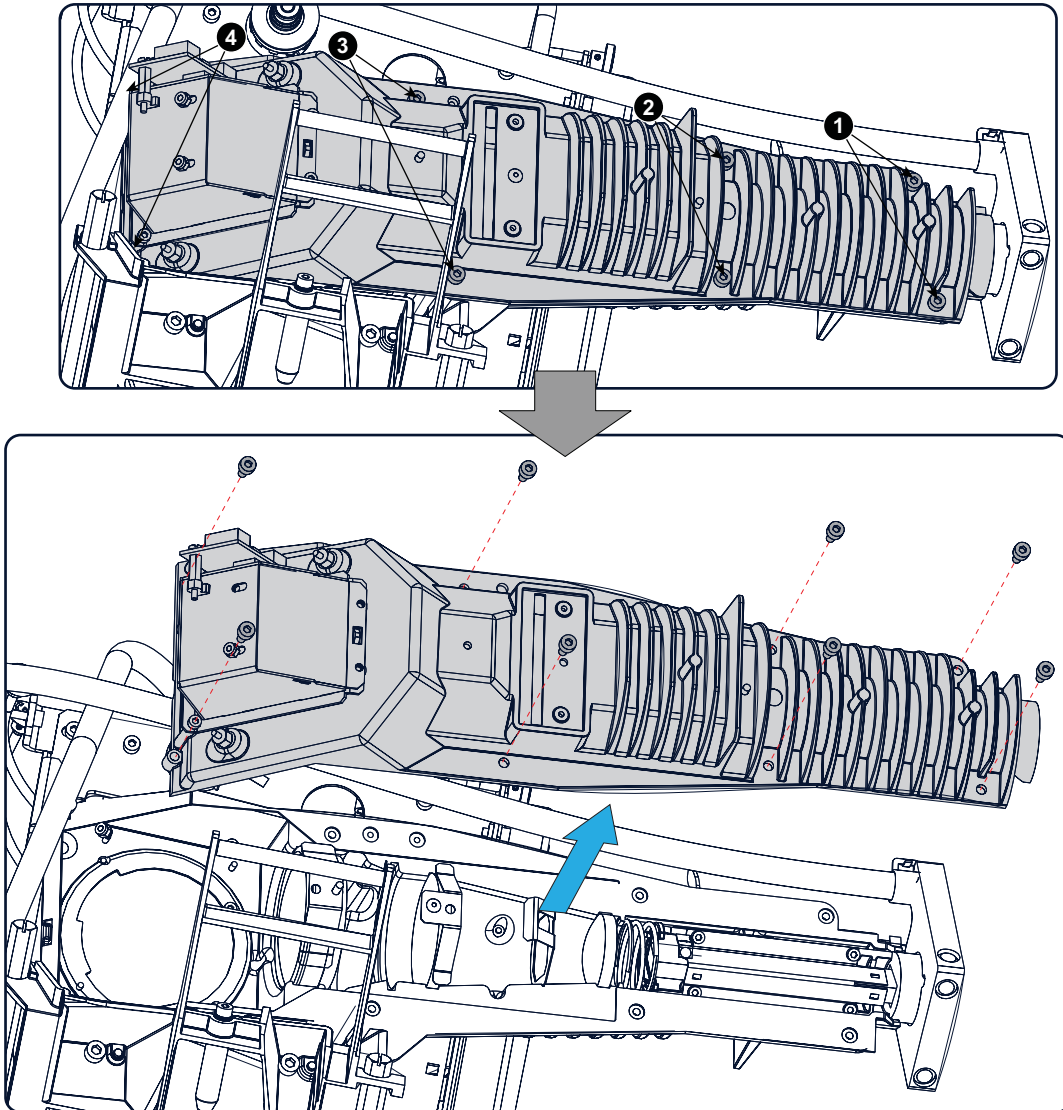

Image 11-4
Light pipe housing

4. Take off the housing.

11. Integrator rod

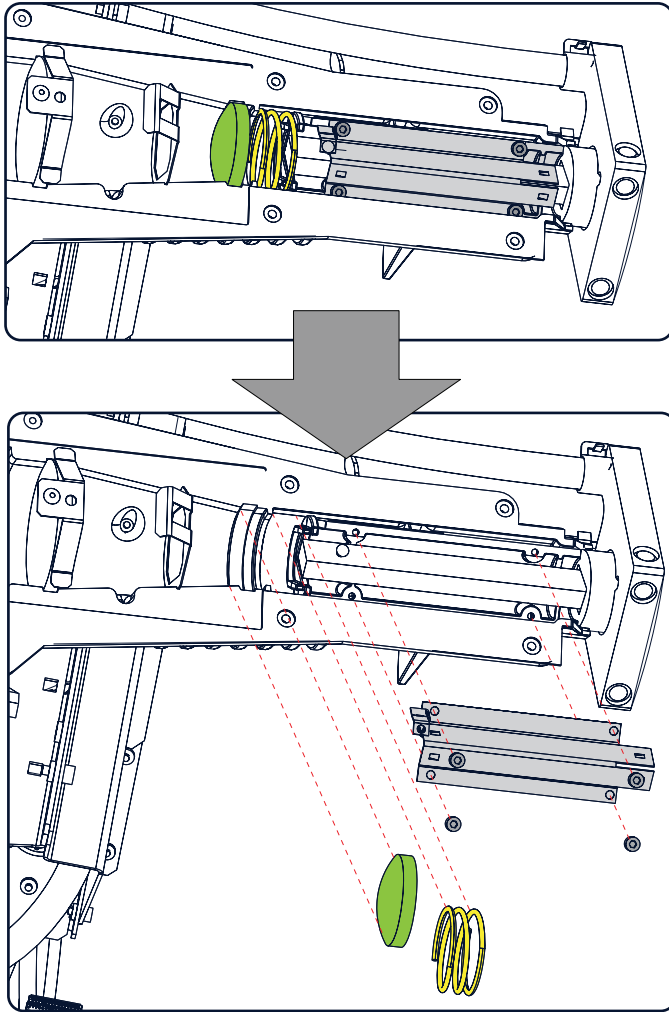

Image 11-5
Inner side light processor

5. Take out the lens.
6. Squeeze the spring and take it out.
7. Remove the 4 screws of the rod cover.
8. Slide the rod to the left until it comes out of the cooling block.
Then, take out the rod.

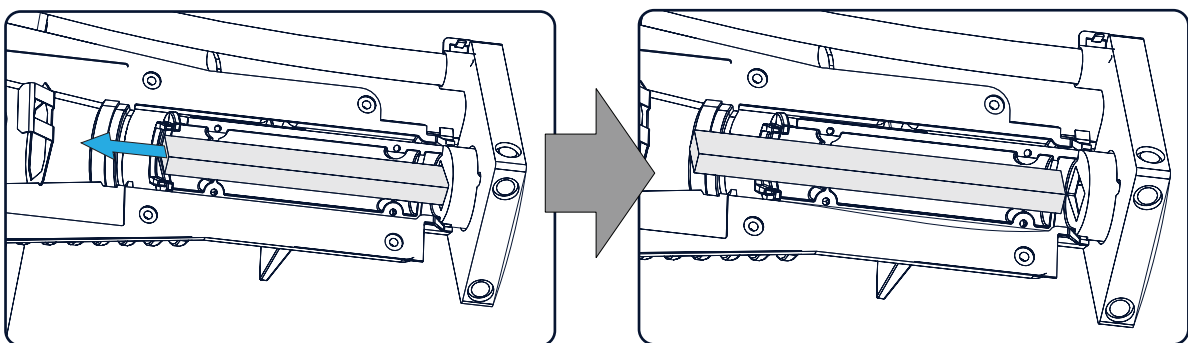

Image 11-6
Moving rod

11.4 Installation of a new integrator rod



CAUTION: Use cotton gloves to handle the integrator rod. Greasy fingerprints or other dirt on the integrator rod will burn into the rod and cause permanent damage.

How to install

1. Unpack the new integrator rod very carefully.
Be careful not to damage the integrator rod.
2. From the left, slide the integrator rod into the opening in the cooling block (1) Do not touch the entrance of the integration rod to any mechanical part of the cooling block. That can damage the rod severely with a bad image as result.

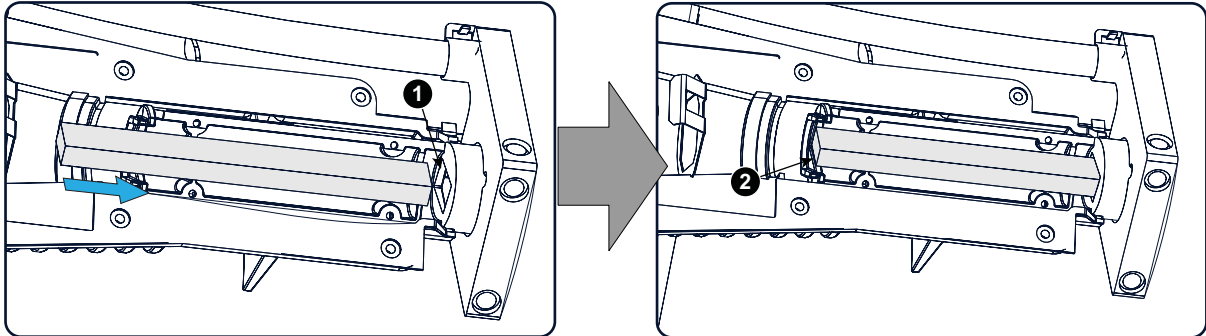

Image 11-7
Mount integration rod

3. Slide it in so that the front of the other side of the integrator rod is equal with entrance of the rod holder (2)
Again, do not slide in the integrator rod too far to avoid damage to the entrance of the rod.
4. Place the integrator rod cover plate on its place (1) and secure with the 4 screws (2).

11. Integrator rod

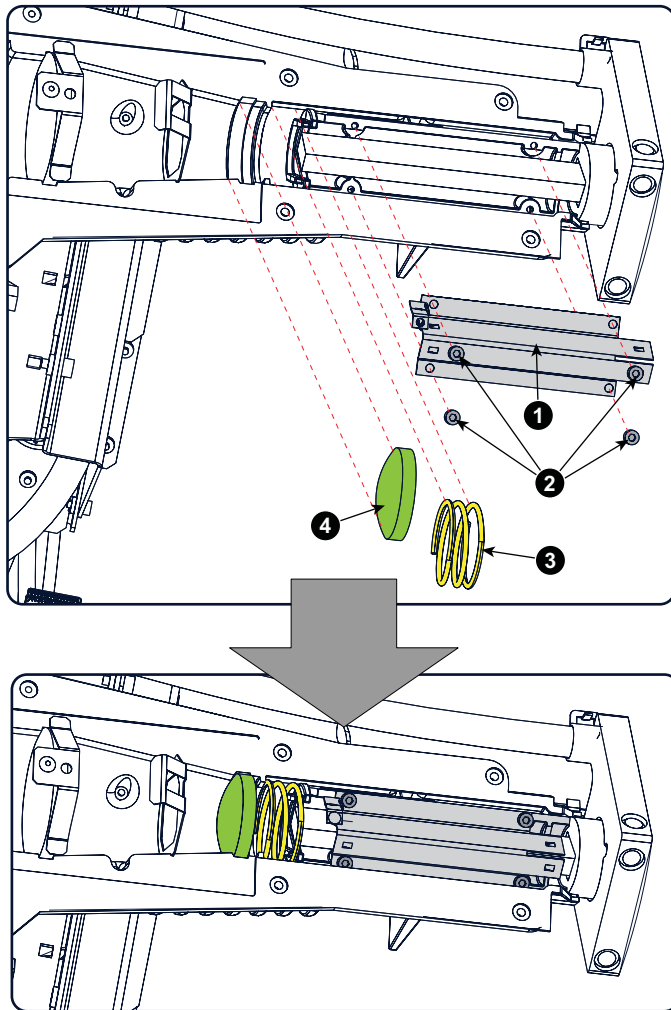

Image 11-8
Light pipe, inside

5. Take the spring, squeeze it and insert it in the compartment (reference 3, image 11-8).
Do not touch the output of the integrator rod while inserting the spring.
Release the spring once it is on its place.
6. Insert the lens with the convex side to the left (away from the rod entrance cooling block) (reference 4, image 11-8).
7. Place the light pipe housing back on its place and secure with 4 x 2 screws.

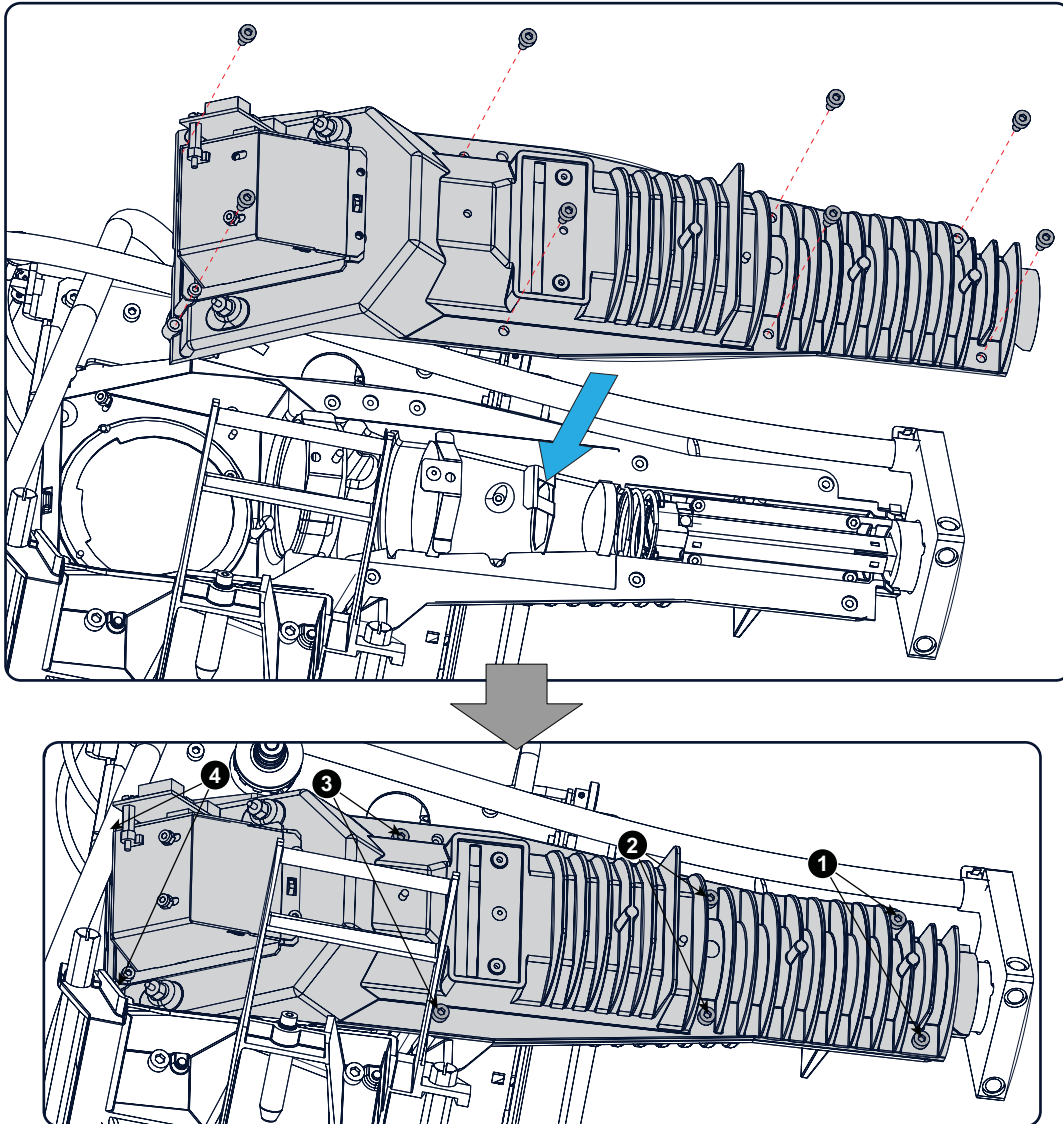

Image 11-9
Light pipe cover, mount

8. Insert the eye plate and secure with both screws.

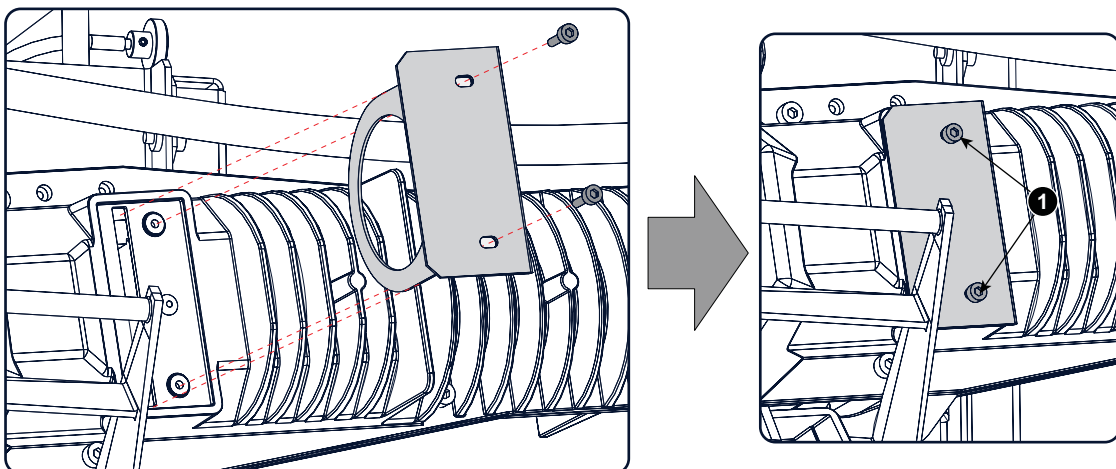

Image 11-10
Eye plate, insert

9. Connect the light sensor cable to the light sensor unit.



Normally the adjustment of the integrator rod should be correct. If not correct, continue with "Adjusting the integrator rod", page 183.

11.5 Adjusting the integrator rod

Necessary tools

- Wrench 7 mm
- Torque wrench 7 mm

How to adjust

1. Loosen the lock nut on the light pipe.

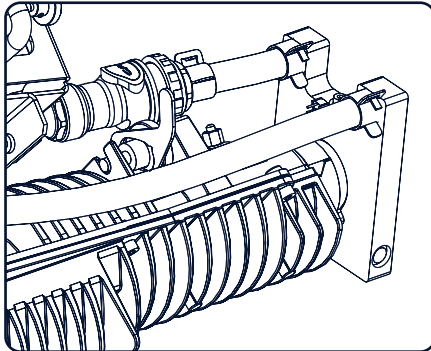
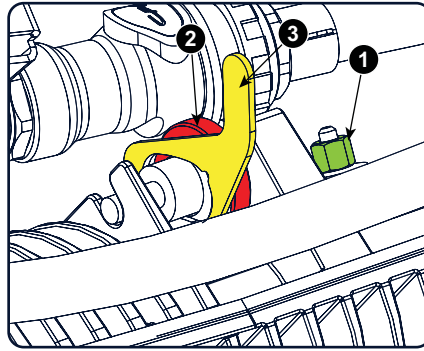

Image 11-11
Integrator rod adjustment



2. start up the projector but do not activate the lamp yet.
3. By using the Communicator software, set up the projector to display a white internal pattern with minimum lamp power. Do not activate the lamp yet !
 - a) Switch on the projector. Do not activate the lamp yet.
 - b) Log on to the Communicator as "Service technician" and select: Installation > Lamp > Light output, and adjust lamp dimming slider to 0.
 - c) Select: Control > Test patterns > Full white

Caution: Maximum five (5) seconds are allowed of minimum light output on a non-adjusted Integration Rod. Otherwise, the sealing between the DMD's and the prism will be damaged.
4. Activate the lamp and zoom the projector lens in or out until the projected image is focused.
Note: Test pattern must be displayed sharp.
5. Remove the Fold Mirror cover and the Light Sensor Module as a whole from the Light Pipe as illustrated. Remove both indicated Torx screw (reference 1).

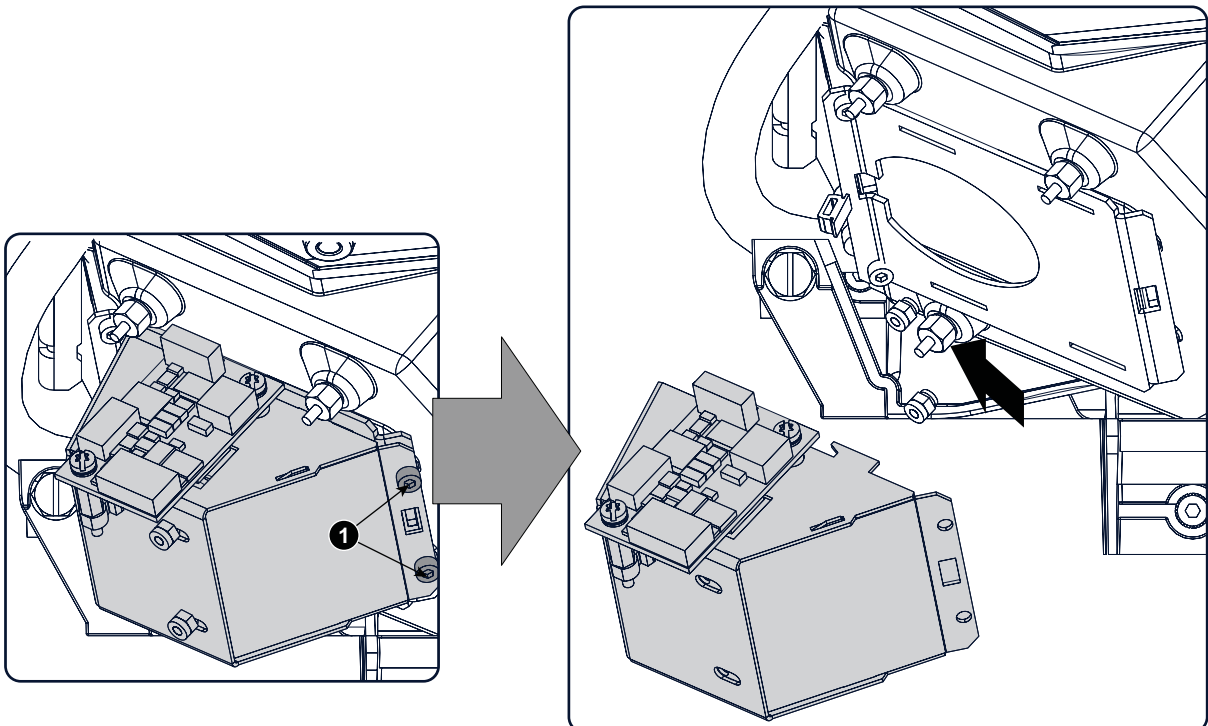

Image 11-12
Fold mirror, access adjustments

11. Integrator rod

6. Turn the lower nut of the folding mirror until the upper and left edge of the rod can be seen on the screen.
7. Gently rotate ring 2 back or forward to a position which projects the sharpest possible edges on the screen.

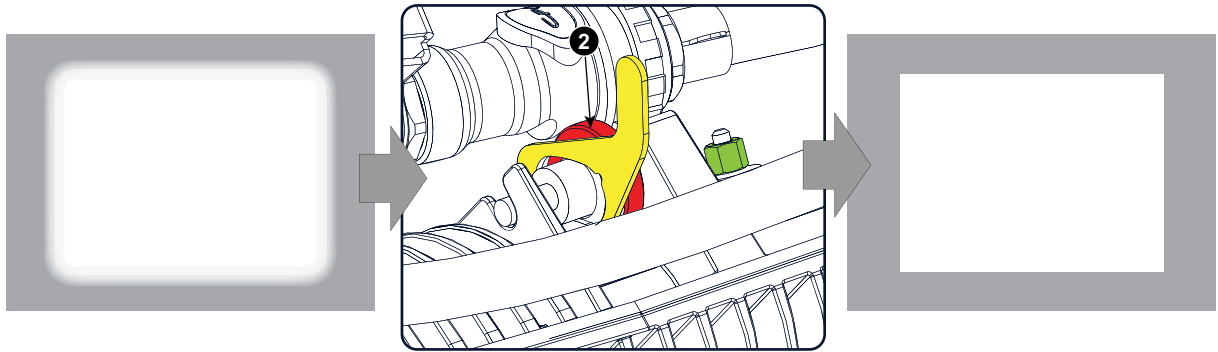

Image 11-13

8. Gently move the handle 3 back or forward to a position so that the projected light beam matches the projected outline of the DMD's

Note: No spots in the projected image may move along with the movements of the rod. Spots which move with the movements of the rod indicates that the exit side of the integrator rod is contaminated with dust. If this is the case, remove the integrator rod and try to blow away the dust. If this doesn't help replace the integration rod.

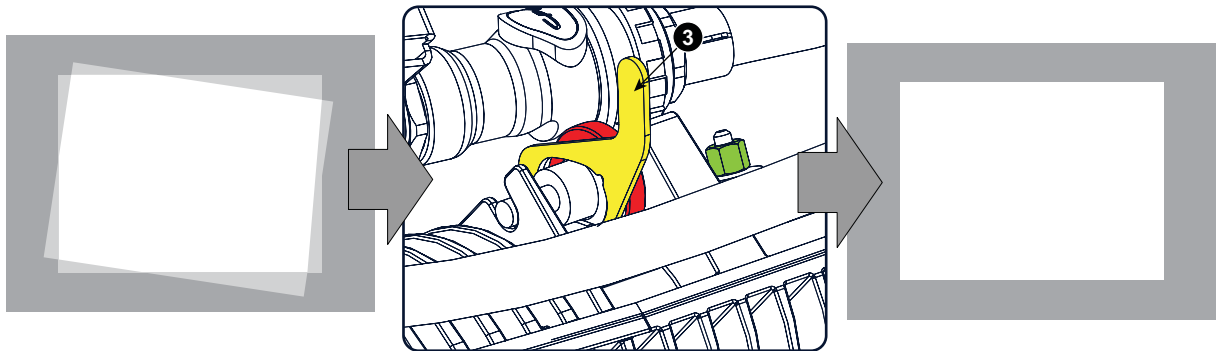

Image 11-14

9. Fasten the lock nut (1) with a torque of **2 Nm**.
10. Turn the lower nut of the folding mirror back to its original position (see alignment procedure of the folding mirror for the correct alignment)
11. Mount the Fold Mirror cover and the Light Sensor Module.

12. LENSES AND LENS HOLDER

Overview

- Available lenses
- Lens selection
- Lens removal
- Lens installation
- Cleaning the lens
- Remove the lens holder
- Install the lens holder
- Scheimpflug adjustment
- Replacement of the Vertical Shift stepper motor
- Replacement of the Horizontal Shift stepper motor
- First Placement of the Inner Dust Rubber
- Replacement of the Inner Dust Rubber

12.1 Available lenses

Which lenses are available for my projector?



The table below is subject to changes and was last updated on 01/06/2012. Consult my.barco.com for the most recent information about available lenses.

| Product Number | Type | Zoom range | Image |
|----------------|-----------|------------|------------|
| R9855957 | Motorized | 1,2 – 1,81 | image 12-1 |
| R98559571 | Manual | 1,2 – 1,8 | |
| R9855931 | Motorized | 1,4 – 2,05 | image 12-2 |
| R98559311 | Manual | 1,4 – 2,05 | |
| R9855932 | Motorized | 1,6 – 2,5 | image 12-3 |
| R9855933 | Motorized | 1,6 – 2,5 | image 12-4 |
| R98559321 | Manual | 1,6 – 2,5 | image 12-5 |
| R98559331 | Manual | 1,6 – 2,5 | |
| R9855934 | Motorized | 1,95 – 3,2 | image 12-6 |
| R9855935 | Motorized | 1,95 – 3,2 | image 12-7 |
| R98559341 | Manual | 1,95 – 3,2 | image 12-8 |
| R98559351 | Manual | 1,95 – 3,2 | |
| R9855936 | Motorized | 2,4 – 3,9 | image 12-9 |
| R98559361 | Manual | 2,4 – 3,9 | |



Image 12-1
R9855957



Image 12-2
R9855931



Image 12-3
R9855932



Image 12-4
R9855933



Image 12-5
R98559321



Image 12-6
R9855934



Image 12-7
R9855935



Image 12-8
R98559341



Image 12-9
R9855936

12.2 Lens selection

Which lens do I need?

- Go to Barco's website on www.barco.com and click on myBarco
- Login on.
If you are not yet registered create a login and password. With the created login and password, it is possible to enter myBarco. When your login is correct, the start page is displayed.
- Click the **Support** tab, then **Digital cinema calculator** (on the left of the screen) and select the appropriate lens calculator. The lens calculator (see screenshot, image 12-10) will be displayed.

The lens calculator allows you to have an overview of which lenses are suitable for your specific projector setup. Just make your selection of parameters and all possible configurations are displayed.

Digital cinema Lens calculator - Series 2

Barco.com | Digital Cinema Calculator - Series 2 - Beta

Make your selection

Resolution: only 4k only 2k

Projection: 2D projection 3D projection

Masking: Side Masking Top Masking

Screen Width: (Flat/Scope)

Screen Height:

Projector Distance: m

Screen gain:

Optical losses: %

Lamp life: %

Foot-Lambert: fL

Required lens ratios: scope: 2.32 flat: 3; scope 4K: 2.57 flat 4K: 3.32

Possible configurations

DP4K-32B
Ultra-bright Enhanced 4K DLP Cinema® projector
Lamp: 6,5k-W High Performance Bulb

Available lenses: 1.38" DC4K (1.13-1.31), 1.38" DC4K (1.27-1.86), 1.38" DC4K (1.45-2.13), 1.38" DC4K (1.63-2.53), 1.38" DC4K (1.95-3.26), 1.38" DC4K (2.53-4.98)

Required lens ratios: scope: 2.32 flat: 3

DP2K-19B
Ultra-bright DLP Cinema® projector for screens up to 19m (62R)
Lamp: 3k-W Standard short-arc Bulb

Available lenses: 1.2" DC2K (1.25-1.45), 1.2" DC2K (1.4-2.05), 1.2" DC2K (1.6-2.35), 1.2" DC2K (1.8-2.8), 1.2" DC2K (2.15-3.6), 1.2" DC2K (2.8-5.5)

Required lens ratios: scope: 2.32 scope 4K: 2.57 flat: 3 flat 4K: 3.32

DP2K-12C

Available lenses: 0.98" DC2K (1.2-1.8)

Image 12-10
Digital cinema lens calculator



Take into account that when the projector is tilted the Screen Width you have to fill in should be larger than the physical screen width due to the keystone distortion of the projected image. How much larger depends on the amount of tilt.



Due to production tolerances the real distances can differ by 2% from the calculated values. For critical situations (fixed installs that use the lens at one of its extreme zoom positions) this should be taken into account.

12.3 Lens removal

How to remove a lens from the projector lens holder ?

1. Support the lens with one hand while you unlock the lens holder by sliding the lock handle towards the "unlocked" position as illustrated.

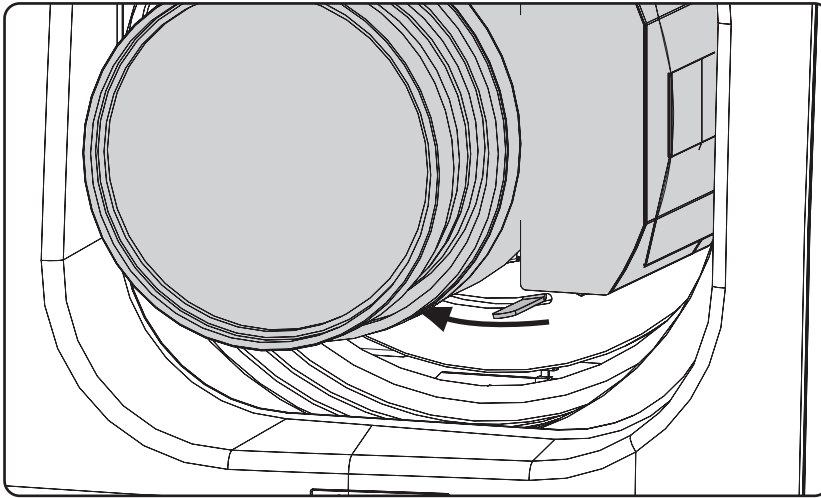
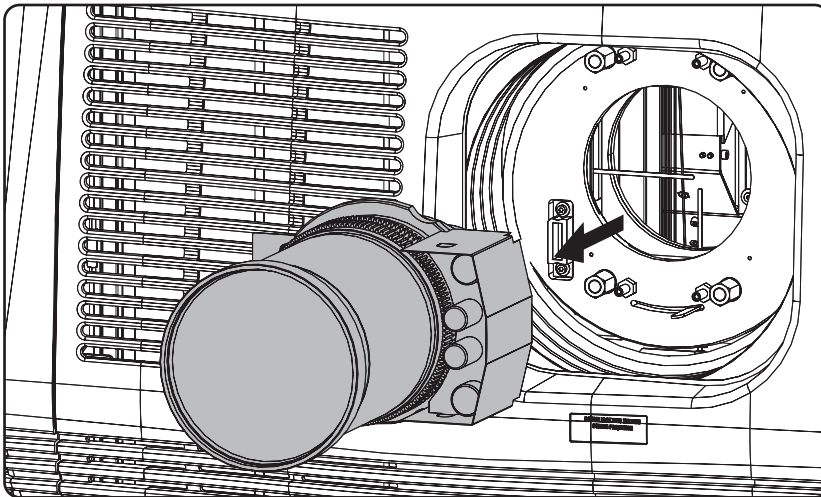

Image 12-11

2. Gently pull the lens out of the lens holder.

Image 12-12
Remove lens

It's recommended to place the Lens caps of the original Lens packaging, back on both sides of the removed Lens to protect the optics of the Lens.



It's recommended to place the foam rubber of the original projector packaging, back into the Lens opening to prevent intrusion of dust. Note that this foam rubber is packed in a plastic bag to prevent the dust, emitted by the foam, from entering the projector.

12.4 Lens installation

How to install a lens into the projector lens holder ?

1. Remove the foam rubber in the opening of the lens holder if not removed yet.
2. Take the lens assembly out of its packing material and remove the lens caps on both sides.
3. Close the lens locking mechanism prior to lens insertion (1). Lens locking mechanism is closed by pushing the lens lock to the right.

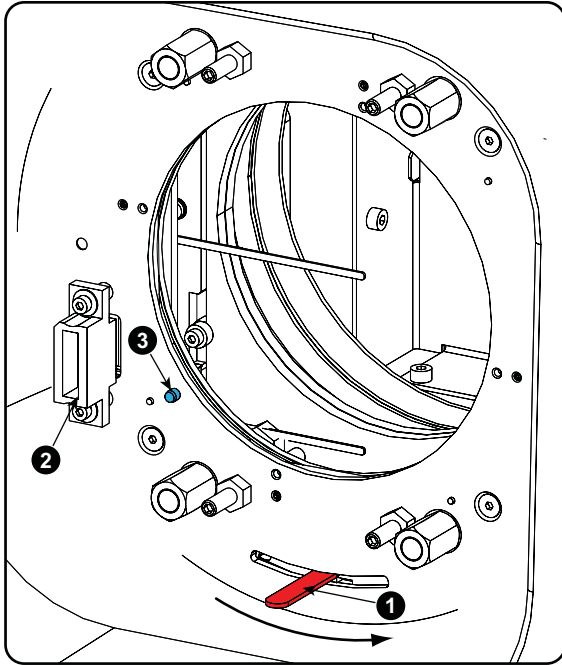

Image 12-13

- 1 Lens holder lock
- 2 Power connector lens
- 3 Alignment pin

4. Ensure that the lens holder stands in the On-Axis position (horizontal and vertical mid position).
Note: The lens holder is placed default in the On-Axis position at factory.
5. Gently insert the lens in such a way that the lens connector matches the socket (B).

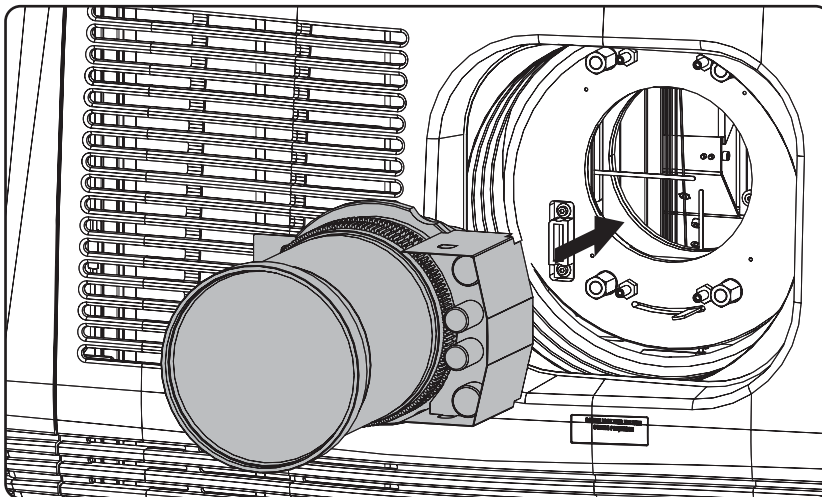

Image 12-14

6. Insert the lens until the connector seats into the socket.
Warning: Do not release the Lens yet, as the Lens may fall out of the Lens Holder.

A clear "click" should be heard when the retainer springs engage into the slot provided on the lens. Besides the clear click, the springs actually help to guide the lens into position and hence prevent jamming.

7. Check if the lens is really secured by trying to pull the lens out of the lens holder.



CAUTION: Never transport the projector with a Lens mounted in the Lens Holder. Always remove the Lens before transporting the projector. Neglecting this can damage the Lens Holder and Prism.

12.5 Cleaning the lens



To minimize the possibility of damage to optical coatings, or scratches to lens surfaces follow the cleaning procedure as described here precisely.

Necessary tools

- Compressed air.
- Clean Toraysee® cloth or any micro fiber lens cleaning cloth.
- Clean cotton cloth.

Necessary parts

Lens cleaner (e.g. Carl Zeiss lens cleaner or Purasol® or any water-based lens cleaner)

How to clean the lens?

1. Blow off dust with clean compressed air (or pressurized air cans⁵).
2. Clean with lens cleaner together with a clean lens cleaning cloth to remove the dust and contamination. Use big wipes in one single direction.
Warning: Do not wipe back and forwards across the lens surface as this tends to grind dirt into the coating.
3. Use a dry lens cleaning cloth to remove left liquid or stripes. Polish with small circles.
4. If there are still fingerprints on the surface, wipe them off with lens cleaner together with a clean lens cleaning cloth. Polish again with a dry one.



If smears occur when cleaning lenses, replace the cloth. Smears are the first indication of a dirty cloth.

5. Pressurized air cans are not efficient if there is too much dust on the surface, the pressure is too low

12.6 Remove the lens holder

Necessary tools

- Nut driver 5.5 mm or an open spanner with SW 5.5
- Allen wrench 5 mm

Electrical disconnections

1. Remove the nut, securing the EMC cable to the frame (image indication 1).

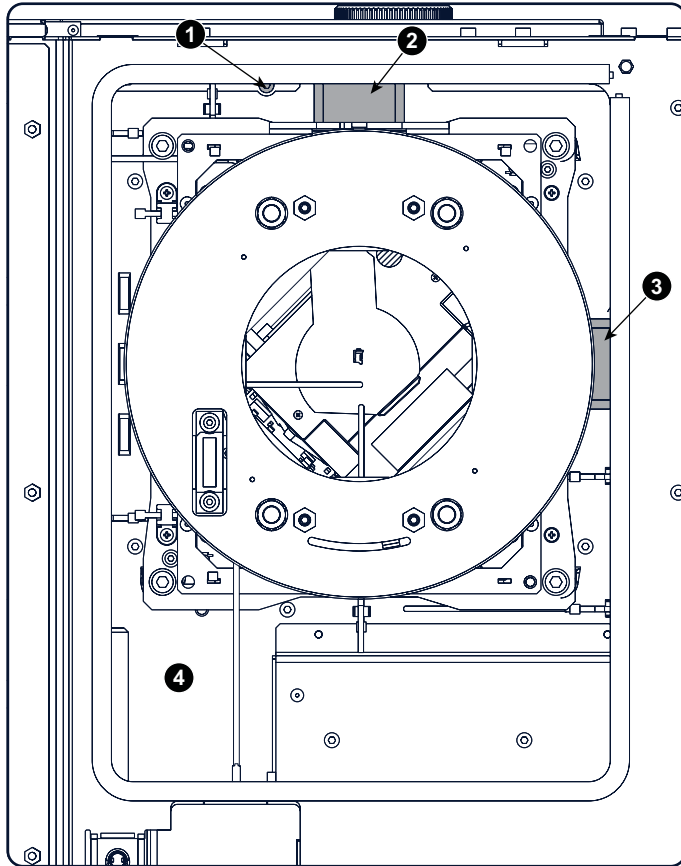

Image 12-15
Electrical connections, location

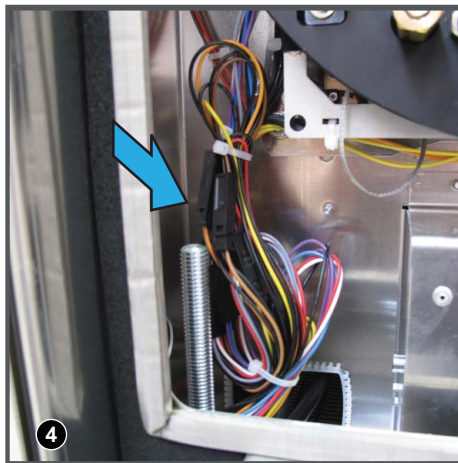
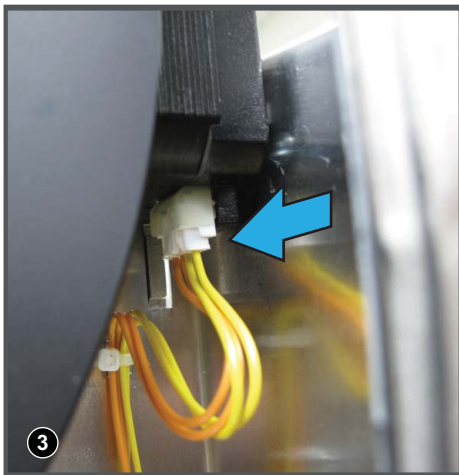
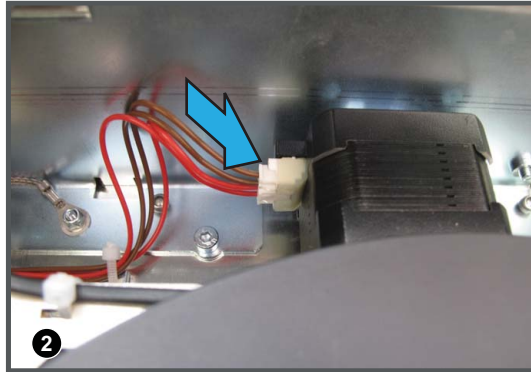
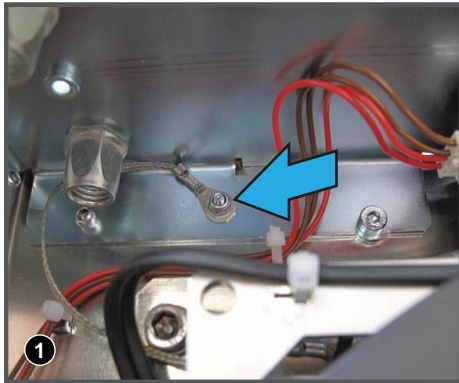

Image 12-16
Electrical connections, image view

2. Unplug the connector of the top motor (image indication 2) (brown and red wires).
3. Unplug the connector of the side motor (image indication 3) (yellow and orange wires).
4. Disconnect all connectors of the wire set (4x 2 pins connectors and 2x 6 pins connectors) (image indication 4).
If necessary, cut the wire ties.

Remove lens holder

1. Remove the 4 hexagon socket heat screws (1 to 4).

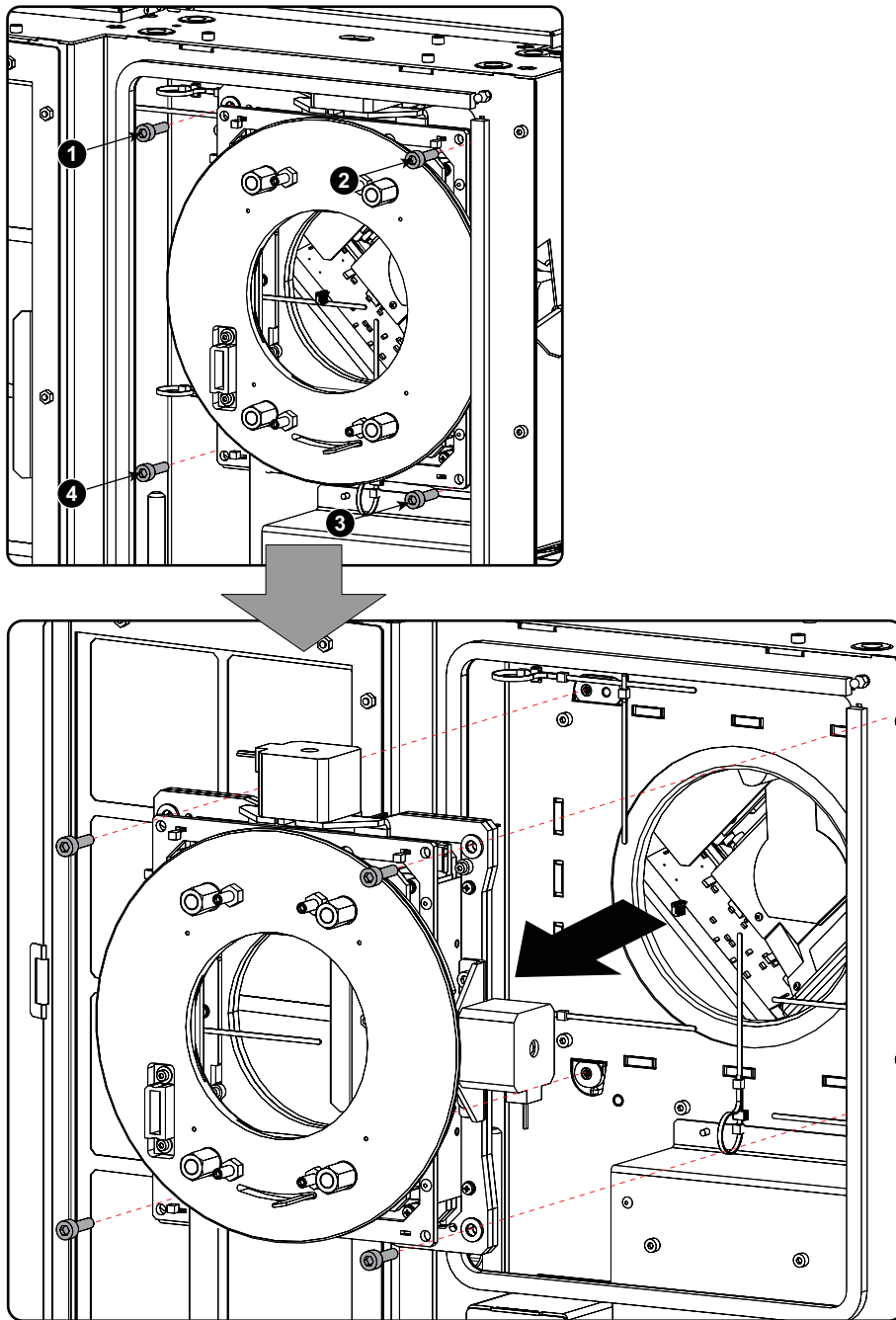

Image 12-17
Remove lens holder

2. Take out the lens holder from the front side of the projector.

12.7 Install the lens holder

Necessary tools

- Nut driver 5.5 mm or an open spanner with SW 5.5
- Allen wrench 5 mm
- 2 spindles of 4 mm or 2 Torx screw drivers T10

Install lens holder

1. Push a spindle or T10 screw driver (P) through the positioning hole A and B.

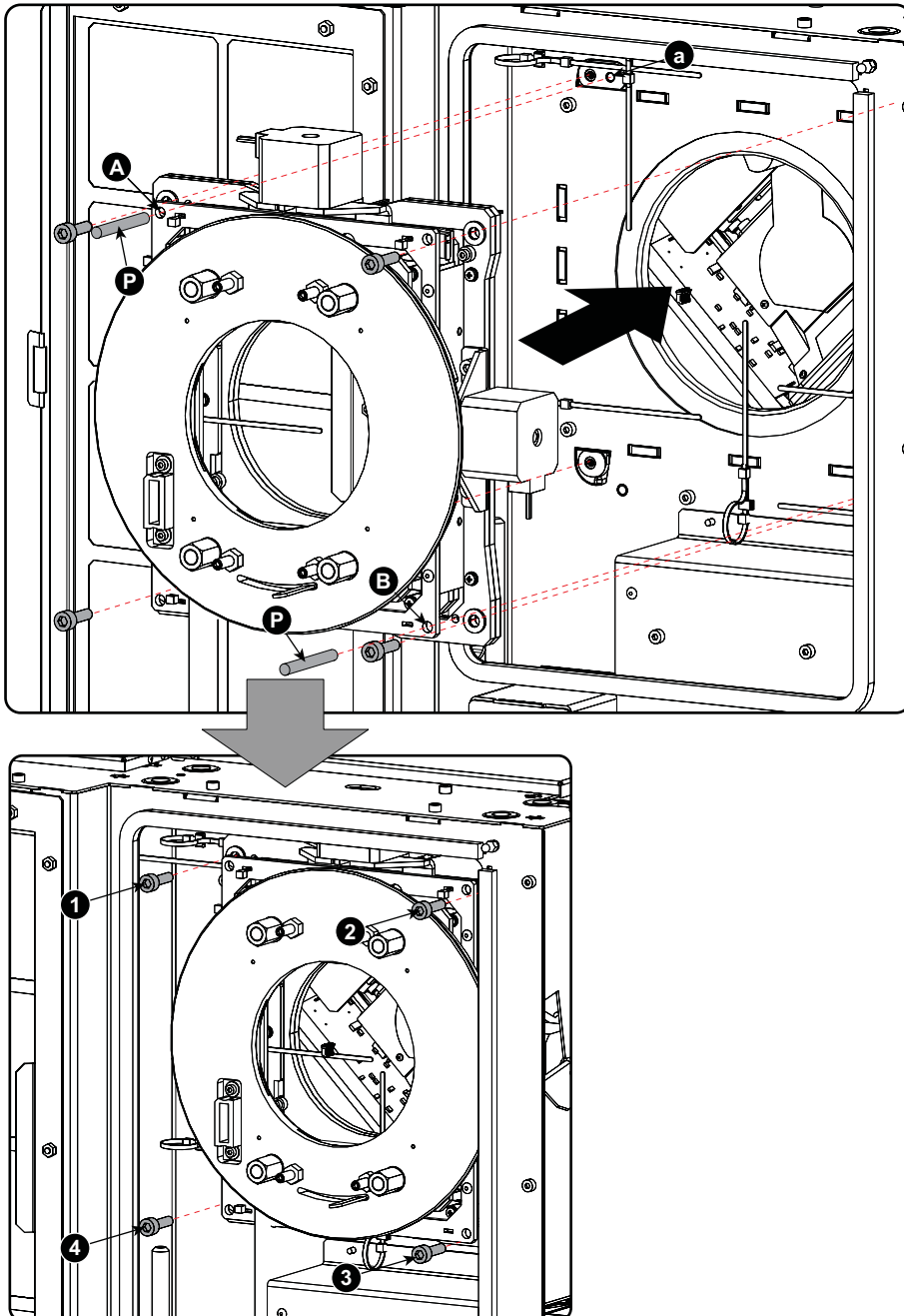

Image 12-18
Mount lens holder

2. Push the end of the spindle into the positioning sockets (a and b (not visible on the drawing)).
3. Push the lens holder against the lens holder plate.
Caution: Make sure that no cables are stuck.
4. Drive in the hexagon socket head screws (1 to 4).

Electrical connections

1. Slide the EMC cable eye on the stud mounted on the frame (image indication 1).
Secure by turning on the nut.

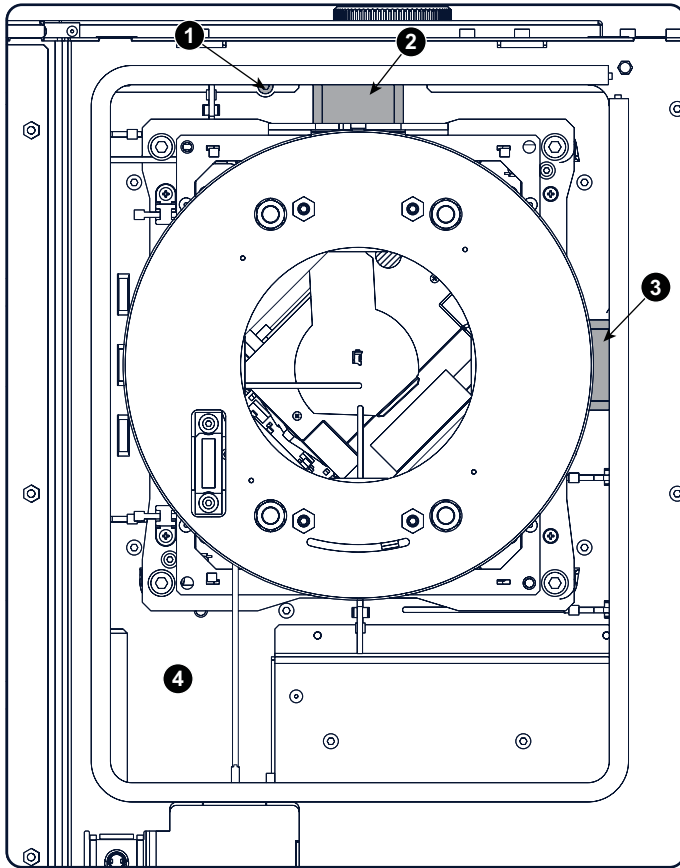

Image 12-19
Electrical connections, location

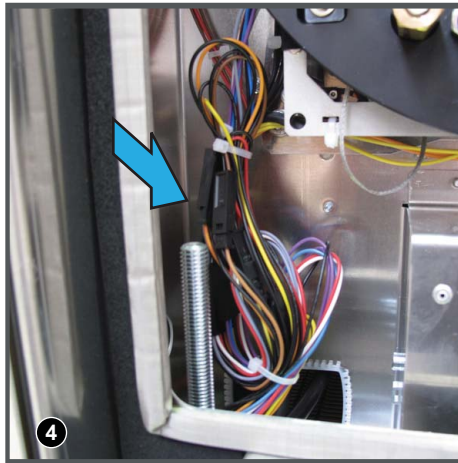
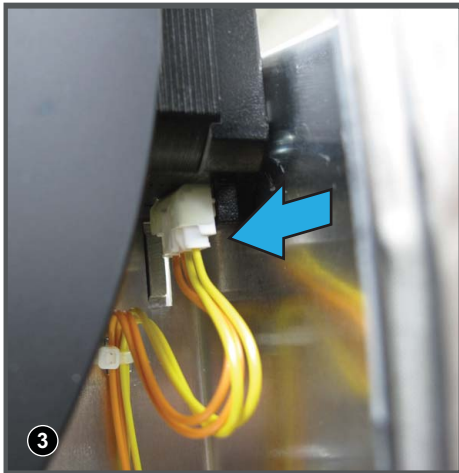
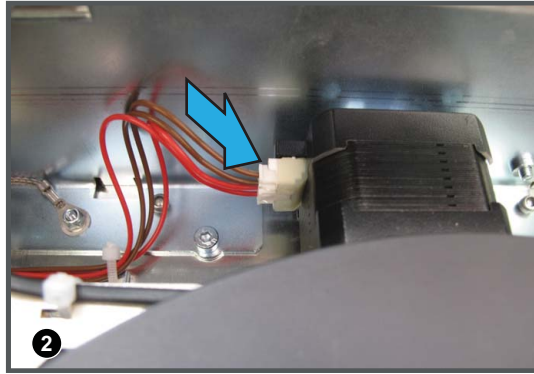
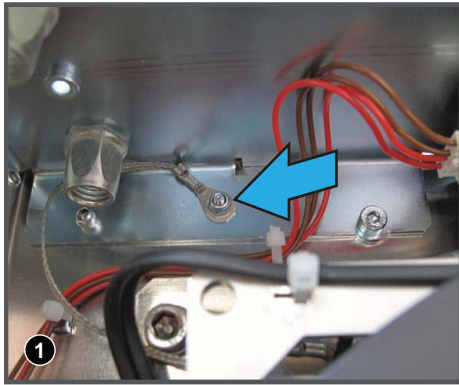

Image 12-20
Electrical connections, image view

2. Plug in the connector of the top motor (image indication 2) (brown and red wires).
3. Plug in the connector of the right motor (image indication 3) (yellow and orange wires).
4. Connect all connectors of the wire set (4x 2 pins connectors and 2x 6 pins connectors) (image indication 4). Connect those connectors with each other that have the same colored wires and exact the same position.
5. Bundle the cables together with a wire tie.

12.8 Scheimpflug adjustment

What has to be done ?

The lens holder has to be adjusted so that the "sharp focus plane" of the projected image falls together with the plane of the screen (Fp1→Fp2). This is achieved by changing the distance between the DMD plane and the lens plane (Lp1→Lp2). The closer the lens plane comes to the DMD plane the further the sharp focus plane will be. It can sometimes happen that you won't be able to get a complete focused image on the screen due to a tilt (or swing) of the lens plane with respect to the DMD plane. This is also known as Scheimpflug's law. To solve this the lens plane must be placed parallel with the DMD plane. This can be achieved by turning the lens holder to remove the tilt (or swing) between lens plane and DMD plane (Lp3→Lp4).

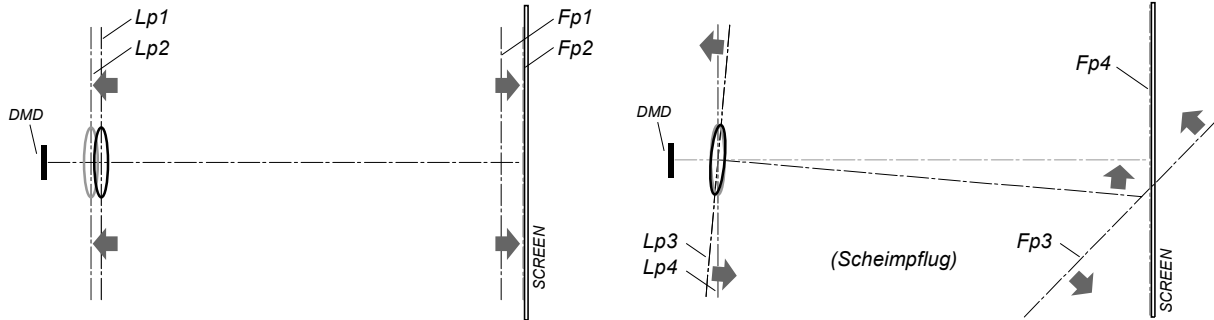

Image 12-21
Scheimpflug principle



Scheimpflug principle

The "plane of sharp focus" can be changed so that any plane can be brought into sharp focus. When the DMD plane and lens plane are parallel, the plane of sharp focus will also be parallel to these two planes. If, however, the lens plane is tilted with respect to the DMD plane, the plane of sharp focus will also be tilted according to geometrical and optical properties. The DMD plane, the principal lens plane and the sharp focus plane will intersect in a line below the projector for downward lens tilt.

Scheimpflug adjustment points

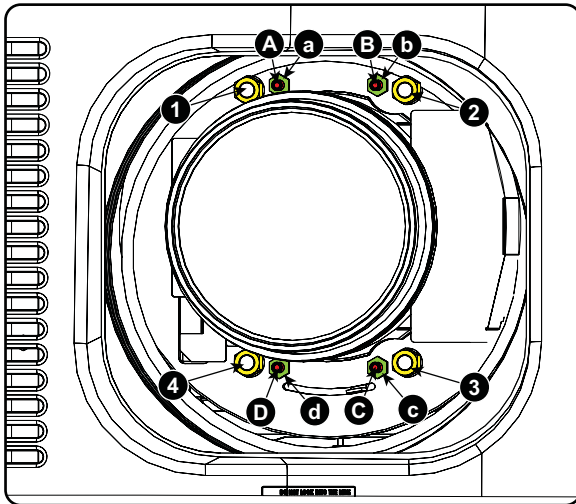

Image 12-22
Scheimpflug adjustments

| Indication on drawing | Function |
|-----------------------|-----------------------------|
| 4 | Locking nut |
| 1, 2 and 3 | Scheimpflug adjustment nuts |
| A, B, C and D | Set screws |
| a, b, c and d | lock nuts |

1, 2 and 3 are adjustment points.

4 is a locking point and NOT used during Scheimpflug adjustment.

Necessary tools

- Allen key 3 mm
- Nut driver 13 mm
- Nut driver 10 mm

How to adjust

1. Project a green focus pattern.

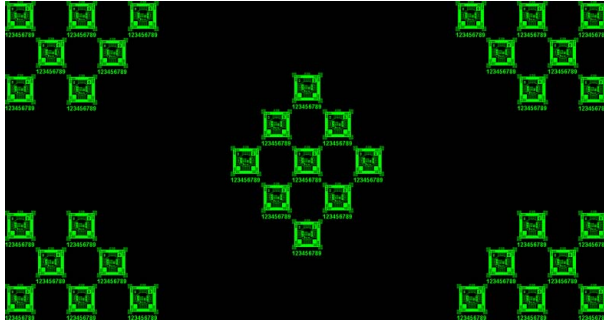

Image 12-23

2. Loosen the lock nuts (a, b, c and d). See image 12-22.
3. Loosen the 4 set screws (A, B, C and D) by 1 cm. See image 12-22.
4. Fully loosen lock nut 4. See image 12-22.
5. Optimize the focus of the projected image as follows:
 - a) Place the zoom lens in TELE position (smallest projected image) and adjust the focus using the lens focus barrel or motorized focus control.
 - b) Place the zoom lens in WIDE position (largest projected image) and adjust the focus by turning equally on nut 1, 2 and 3.
 - c) Repeat steps “a” and “b” until the projected image is as sharp as possible.

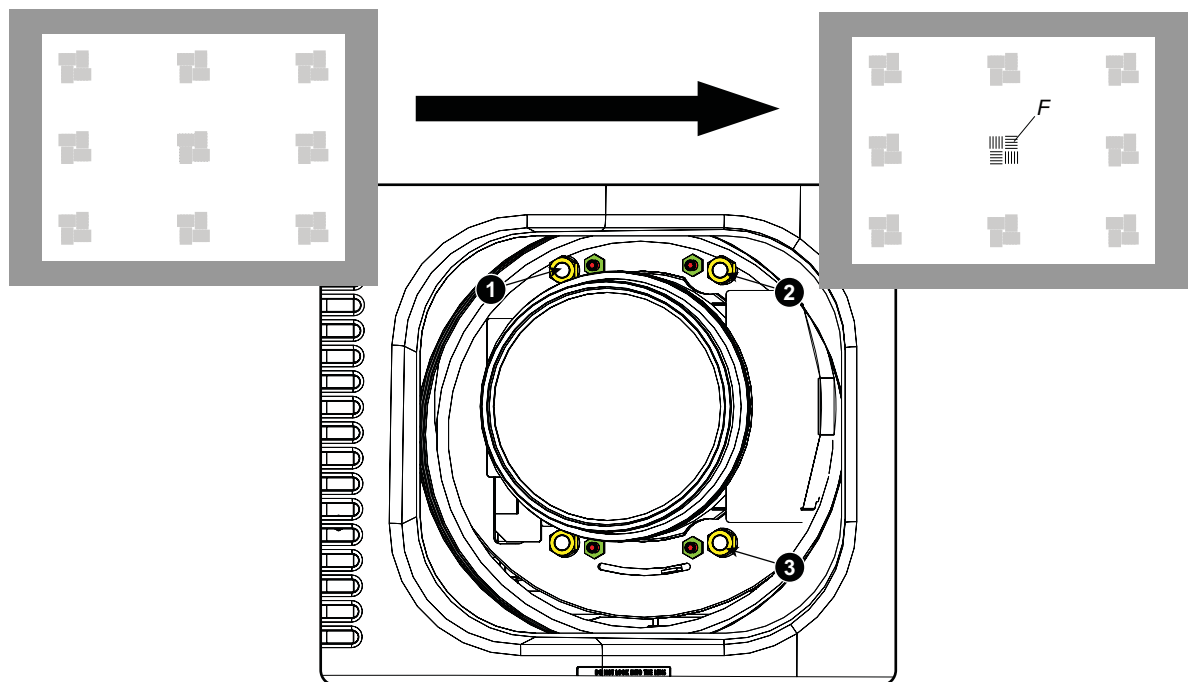

Image 12-24
Center focusing

6. Sharpen bottom left corner of the screen by adjusting nut 1.

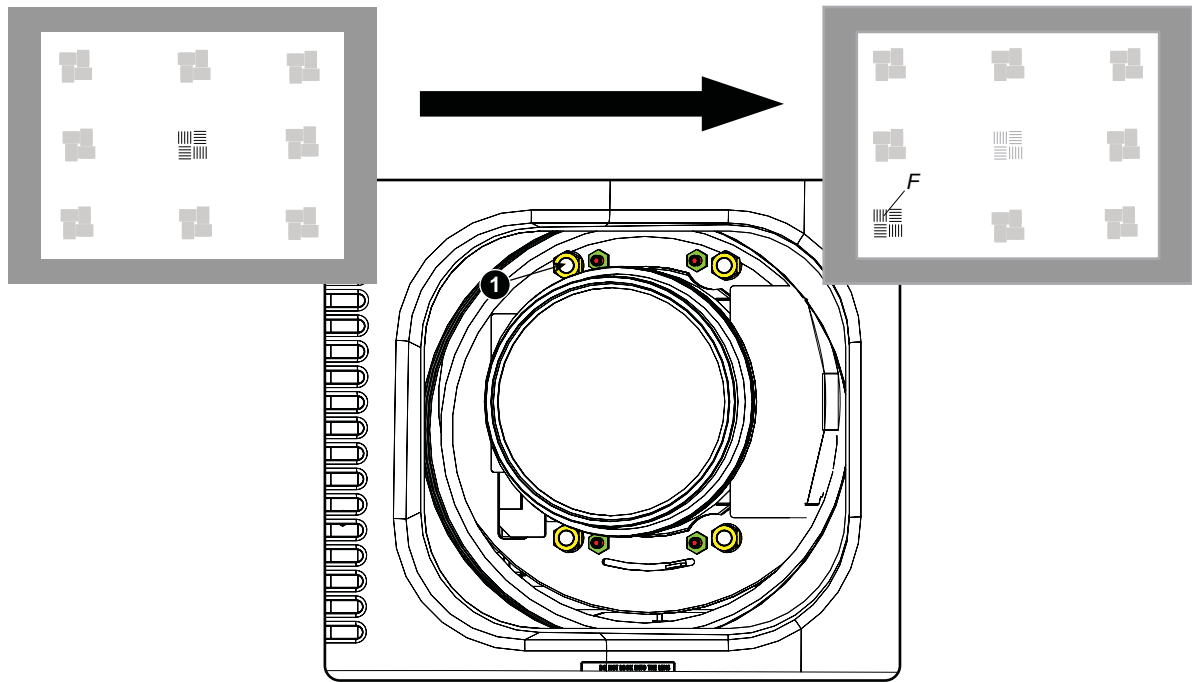

Image 12-25
Left bottom focusing

7. Sharpen bottom right corner of the screen by adjusting nut 2.

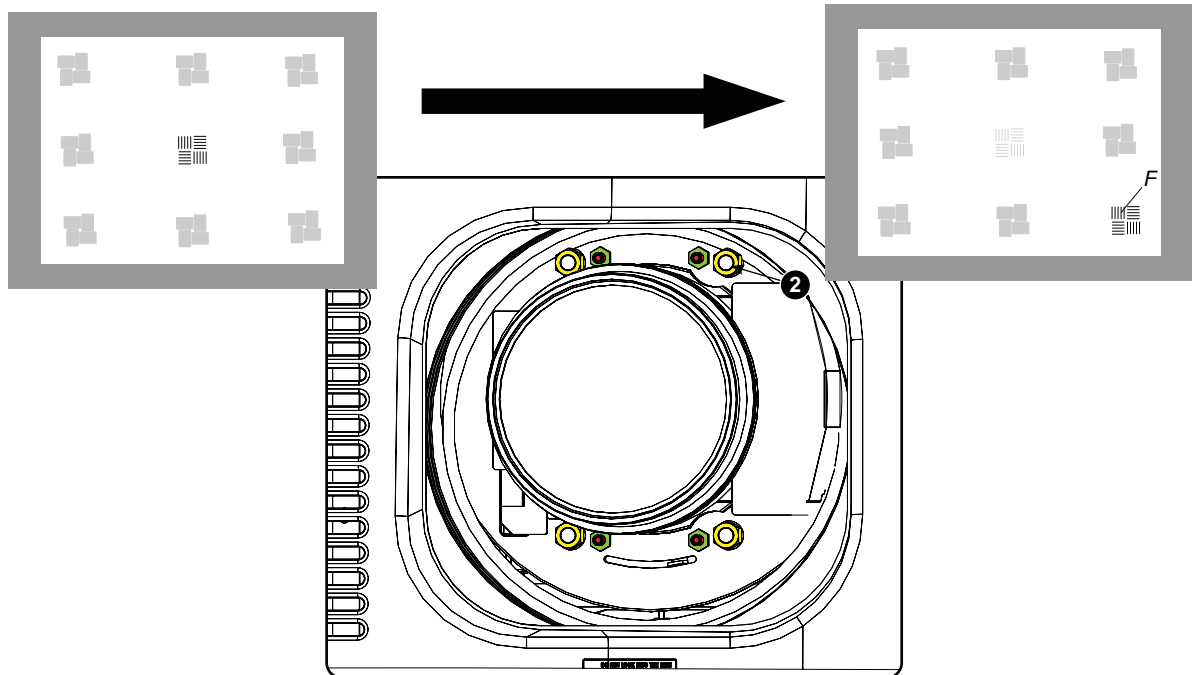

Image 12-26
Right bottom focusing

8. Sharpen top right corner of the screen by adjusting nut 3

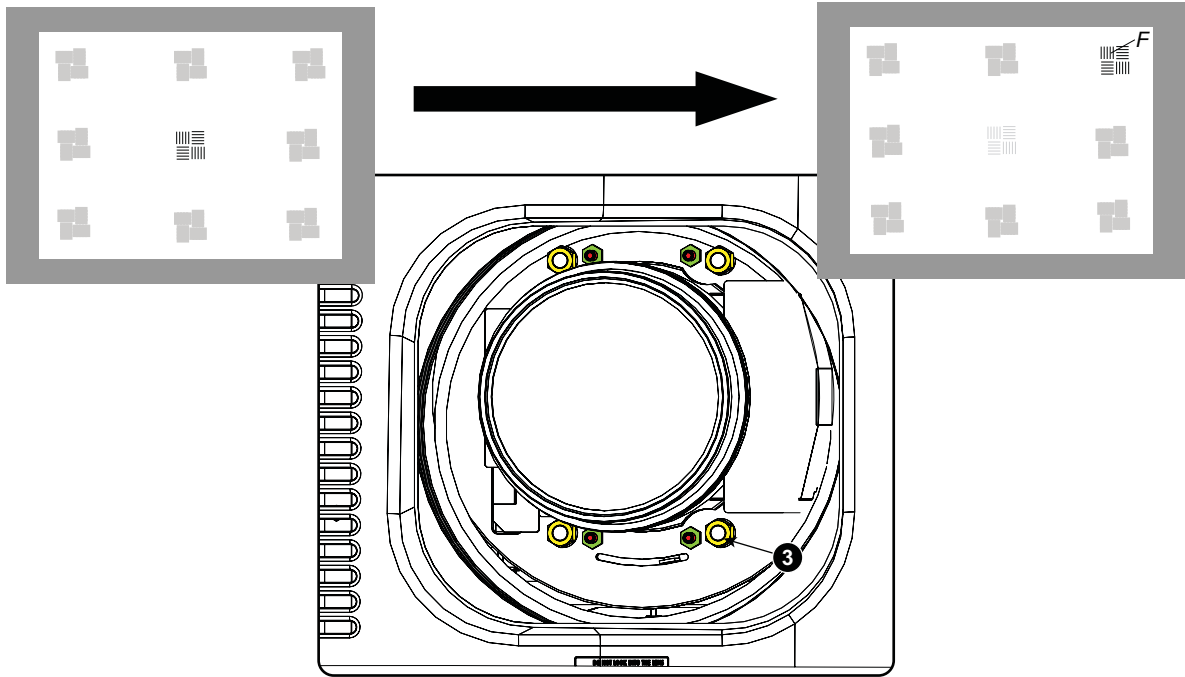

Image 12-27
Corner focusing

- Repeat from step 6 until the projected focus pattern is as sharp as possible in the center, left, right, top and bottom of the screen.

How to fix the Scheimpflug

Start the fixation as follows (steps must be followed strictly) :

- Turn in set screw A, B and C. Tighten lightly (by hand).
Tip: Any movement of the image will affect the Scheimpflug adjustment
- Fasten lock nuts a, b and c.
- Turn in set screw D lightly (by hand) allowing the image to move slightly (1/3 to 1/2 of a square).

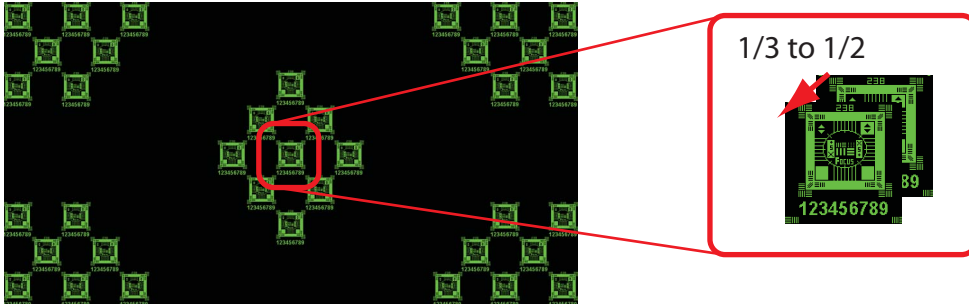

Image 12-28

- Fasten lock nut d.
- Tighten nut 4 until the offset of the image movement created in step 3 is canceled.
Tip: The amount of image movement in step 3 will determine how tight the nut in step 5 will need to be turned to return the image to its original position.

12.9 Replacement of the Vertical Shift stepper motor



This procedure assumes that the Lens Holder is removed from the projector.

Necessary tools

- 3mm Allen wrench.
- 2.5mm Allen wrench.
- 13mm open end wrench.
- 10mm open end wrench.

How to replace the Vertical Shift stepper motor

1. Remove the front plate from the Lens Holder. Use a 13mm open end wrench to loosen the four big nuts (reference 2) as illustrated. It's not necessary to disconnect the Ground wire from the front plate. Just turn the front plate away for accessing the stepper motor.

Caution: Do not loose the three large springs of the Scheimpflug adjustment mechanism.

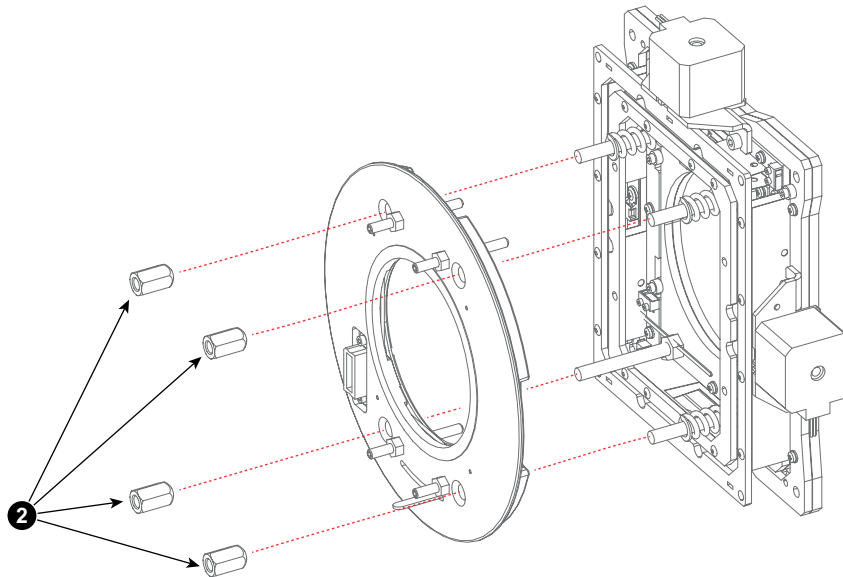

Image 12-29

2. Remove the Vertical stepper motor from the assembly by loosening the four screws (reference 9) as indicated. Use a 3mm Allen wrench.

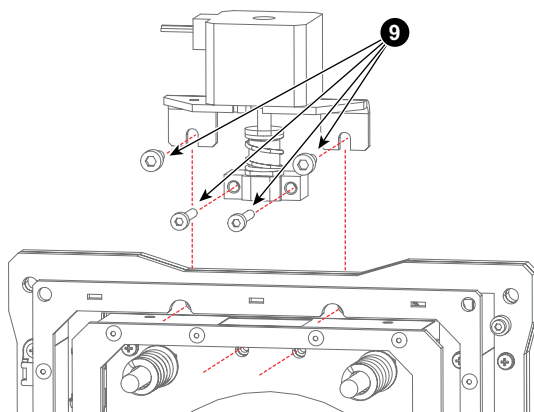

Image 12-30

3. Remove bracket and other parts from the old stepper motor and install these parts on the new stepper motor as illustrated. Use a 2.5mm Allen wrench for the four screws (reference 10) and a 10mm open end wrench (reference 11).

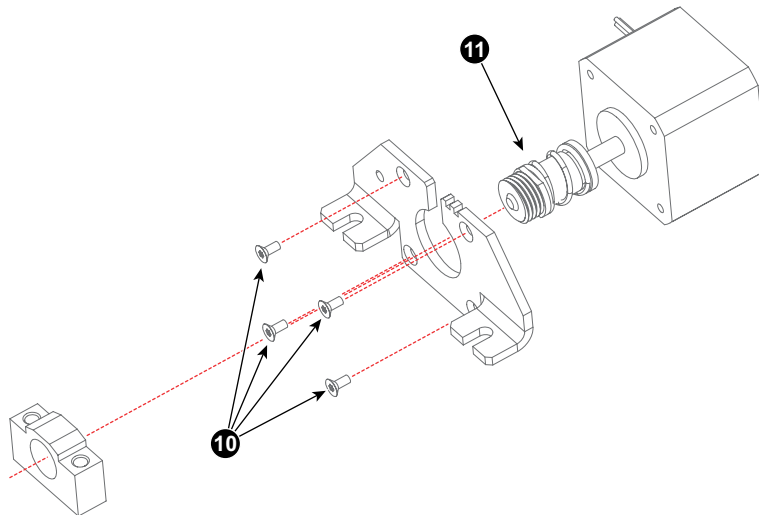

Image 12-31

4. Reinstall the stepper motor on the assembly as illustrated in image 12-30. Fasten the four screws (reference 9) with a 3mm Allen wrench.
5. Reinstall the front plate from the Lens Holder. Use a 13mm open end wrench to fasten the four big nuts (reference 7 image 12-29). Fasten the big nuts crosswise bit by bit. Ensure that the upper two rods and the lower left rod contain a big spring.



Proceed with reinstalling the Lens Holder. See procedure "Install the lens holder", page 196.



The Lens Holder has to be adjusted after installation. See procedure "Scheimpflug adjustment", page 199.

12.10 Replacement of the Horizontal Shift stepper motor



This procedure assumes that the Lens Holder is removed from the projector.

Necessary tools

- 3mm Allen wrench.
- 2.5mm Allen wrench.
- 13mm open end wrench.
- 10mm open end wrench.

How to replace the Horizontal Shift stepper motor

1. Remove the front plate from the Lens Holder. Use a 13mm open end wrench to loosen the four big nuts (reference 2) as illustrated. It's not necessary to disconnect the Ground wire from the front plate. Just turn the front plate away for accessing the stepper motor.

Caution: Do not loose the three large springs of the Scheimpflug adjustment mechanism.

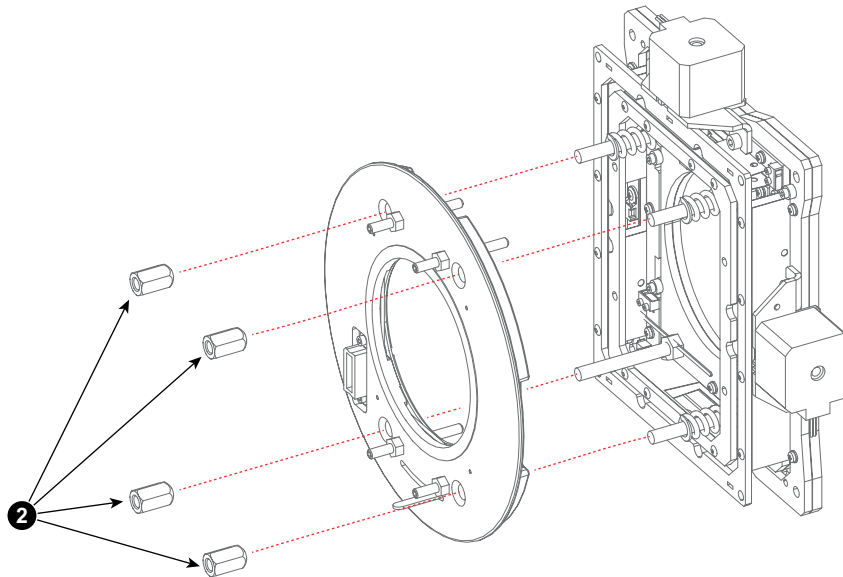

Image 12-32

2. Remove the Horizontal stepper motor from the assembly by loosening the four screws (reference 9) as indicated. Use a 3mm Allen wrench.

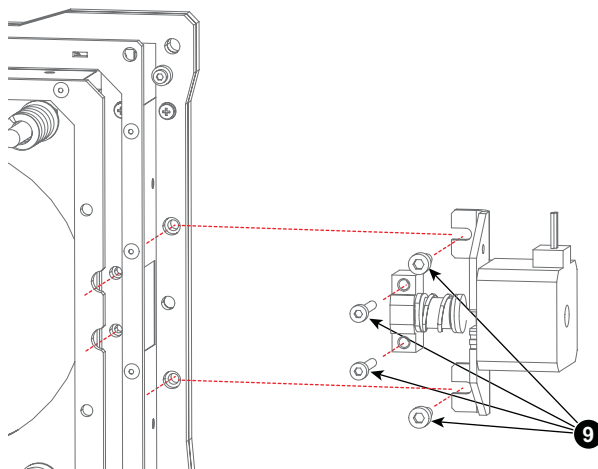

Image 12-33

3. Remove bracket and other parts from the old stepper motor and install these parts on the new stepper motor as illustrated. Use a 2.5mm Allen wrench for the four screws (reference 10) and a 10mm open end wrench (reference 11).

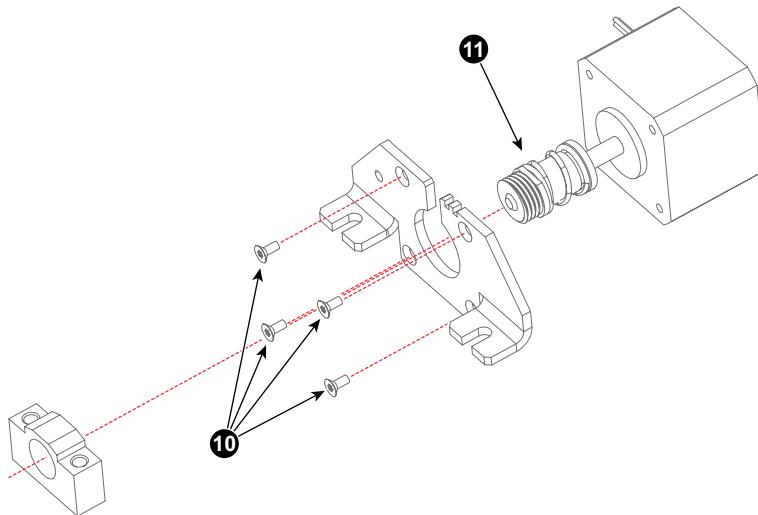

Image 12-34

4. Reinstall the stepper motor on the assembly as illustrated in image 12-33. Fasten the four screws (reference 9) with a 3 mm Allen wrench.
5. Reinstall the front plate from the Lens Holder. Use a 13mm open end wrench to fasten the four big nuts (reference 2 image 12-32). Fasten the big nuts crosswise bit by bit. Ensure that the upper two rods and the lower left rod contain a big spring.



Proceed with reinstalling the Lens Holder. See procedure "Install the lens holder", page 196.



The Lens Holder has to be adjusted after installation. See procedure "Scheimpflug adjustment", page 199.

12.11 First Placement of the Inner Dust Rubber



This procedure assumes that the Lens Holder is removed from the projector.



CAUTION: Be careful as not to damage the inner dust rubber while executing this procedure.

The Dust Rubber Kit

The Lens Holder Inner Dust Rubber kit is an improvement kit designed by Barco and fits perfectly on the Lens Holder of the DP2K-12C/11CX series digital projectors. The Inner Dust Rubber helps prevent dust from entering via the Lens Holder.

While the most recent versions of the DP2K-12C/11CX series will have the Inner Dust Rubber pre-installed, older versions may not yet have this dust rubber installed.

Necessary tools

- 13 mm nut driver or open-end wrench
- 5.5 mm nut driver or box-end wrench
- Phillips PH1 screwdriver

Necessary parts

- Lens holder cover
- Dust rubber frame
- Inner dust rubber
- 6 M3 hex nuts

How to place the Inner Dust Rubber for the first time

1. Remove the front plate from the Lens Holder. Use a 13 mm nut driver to loosen the four Scheimpflug nuts (reference 2 image 12-35) as illustrated. Turn the front plate away to see the Lens Holder cover.

Caution: Do not loose the three large springs of the Scheimpflug adjustment mechanism.

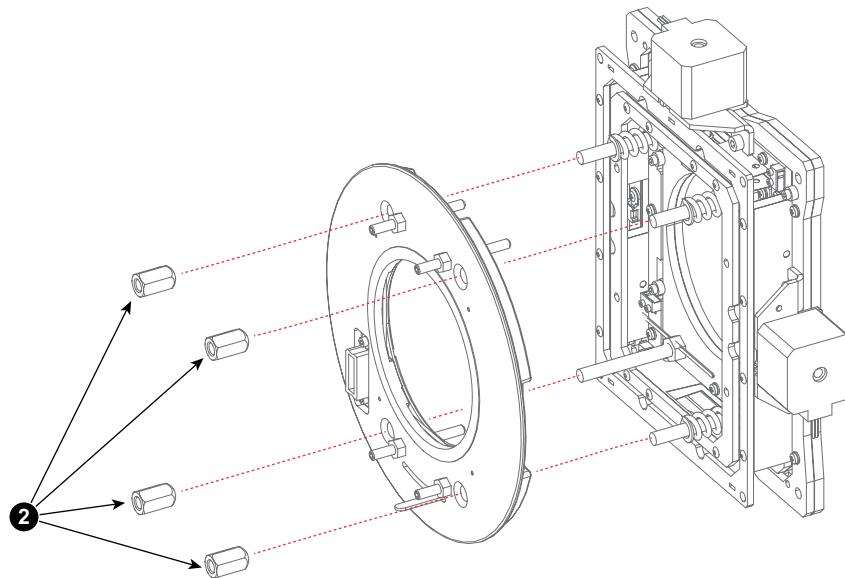

Image 12-35

2. Remove the old Lens Holder cover. Use a Phillips PH1 screwdriver to loosen the seven screws (reference 3 image 12-36) as illustrated. By doing this, you will also release the ground cable (reference 4).

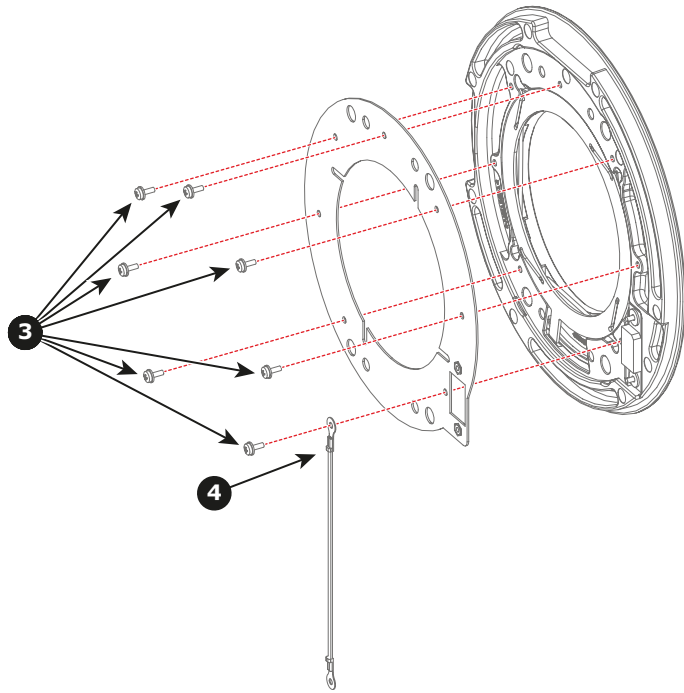

Image 12-36

3. Place the rubber (reference 7 image 12-37) over the pins of the new cover. Carefully place the dust rubber frame (reference 6) over the top of the dust rubber and over the pins of the new cover. Then use a 5.5 mm nut driver to tighten the dust rubber and frame with six hex nuts (reference 5).

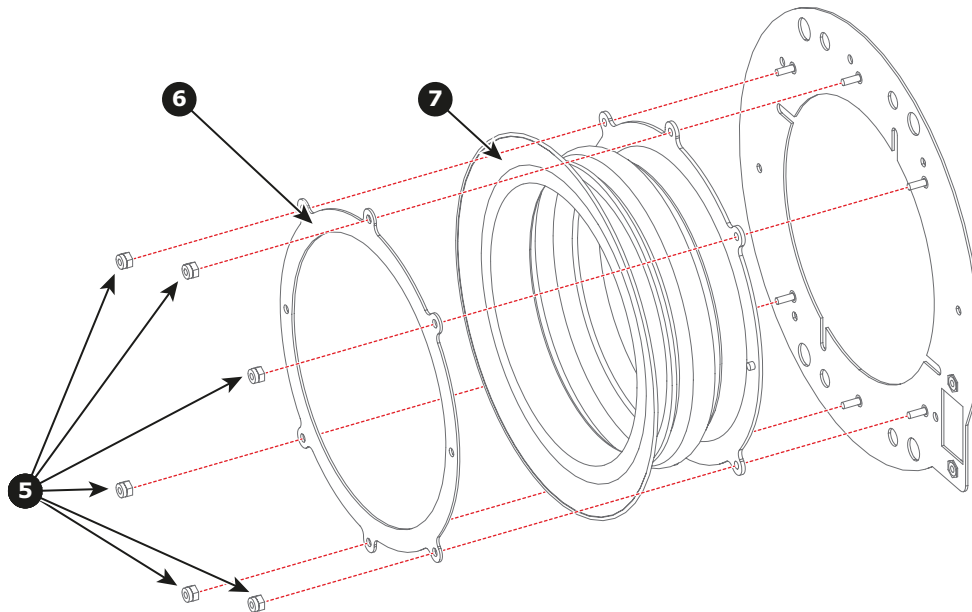

Image 12-37

4. Install the new Lens Holder Cover assembly onto the front plate. Use a Phillips PH1 screwdriver to tighten the seven original screws (reference 3). Make sure you tighten the earth wire (reference 4) back to its original place.

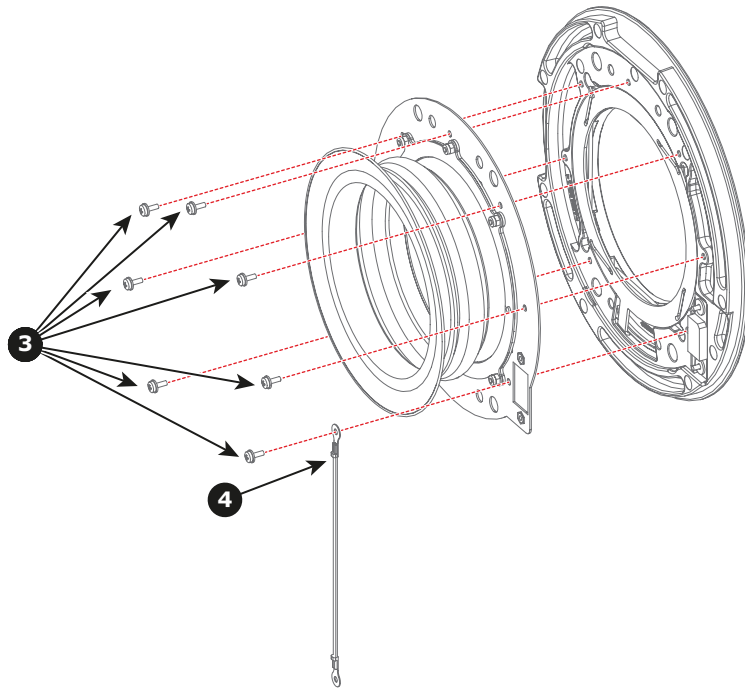

Image 12-38

5. Carefully reinstall the front plate onto the Lens Holder. Help the rubber through the Lens Holder onto the other side.

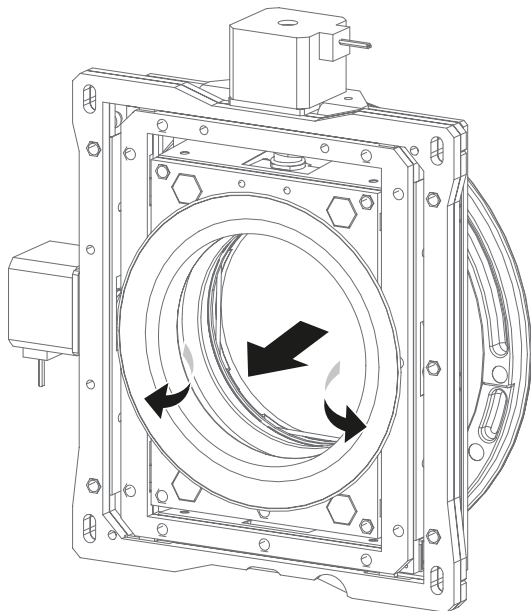

Image 12-39

6. Use a 13 mm nut driver to fasten the four big nuts (reference 2). Fasten the big nuts crosswise bit by bit. Ensure that the upper two rods and the lower left rod contain a big spring.

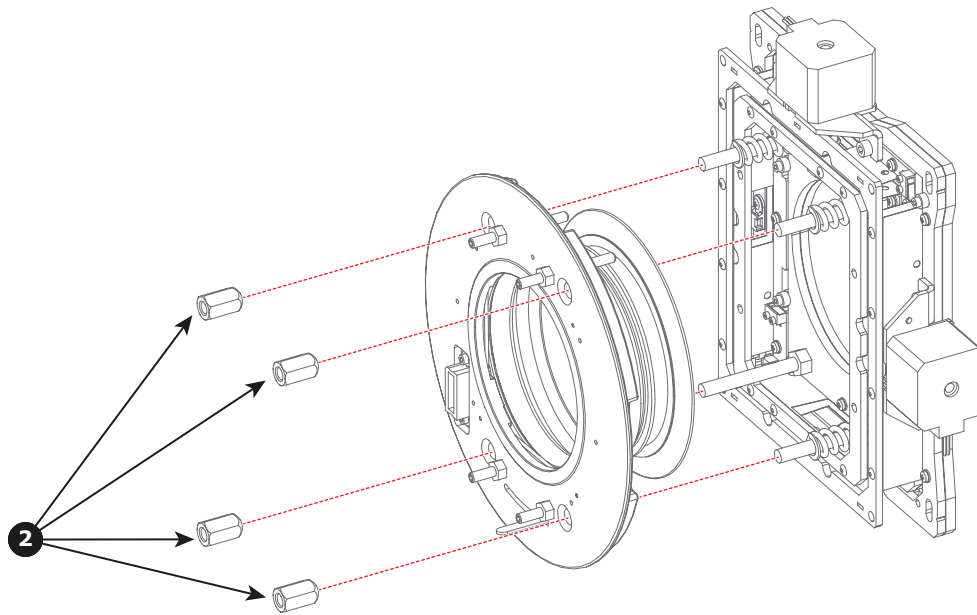

Image 12-40



Proceed with reinstalling the Lens Holder. See procedure "Install the lens holder", page 196



The Lens Holder has to be adjusted after installation. See procedure "Scheimpflug adjustment", page 199.

12.12 Replacement of the Inner Dust Rubber



This procedure assumes that the Lens Holder is removed from the projector.



CAUTION: Be careful as not to damage the new inner dust rubber while executing this procedure.

Necessary tools

- 13 mm nut driver or open-end wrench
- 5.5 mm nut driver or box-end wrench
- PH1 Phillips screwdriver

Necessary parts

- Lens holder cover
- Dust rubber frame
- Inner dust rubber
- 6 M3 hex nuts

How to replace the Inner Dust Rubber

1. Remove the front plate from the Lens Holder. Use a 13 mm nut driver to loosen the four big nuts (reference 2 image 12-41) as illustrated. Turn the front plate away to see the Lens Holder cover.

Caution: Do not loose the three large springs of the Scheimpflug adjustment mechanism.

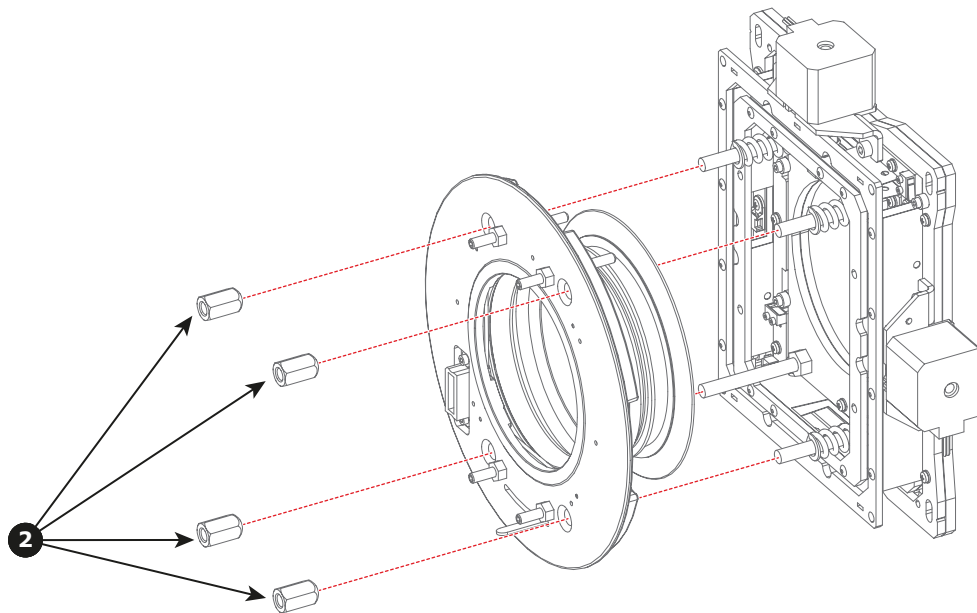

Image 12-41

2. Remove the Lens Holder cover. Use a PH1 Phillips screwdriver to loosen the seven screws (reference 3 image 12-42) as illustrated. By doing this, you will also release the ground cable (reference 4).

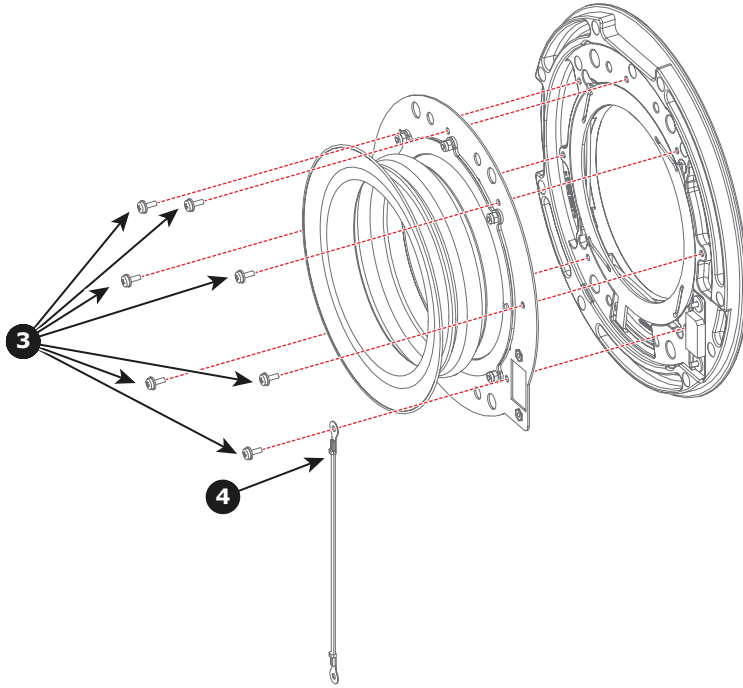

Image 12-42

3. Use a 5.5 mm nut driver to loosen the six nuts on the dust rubber (reference 5 image 12-43). Remove the nuts, the inner dust rubber frame (reference 6) and the old rubber (reference 7).

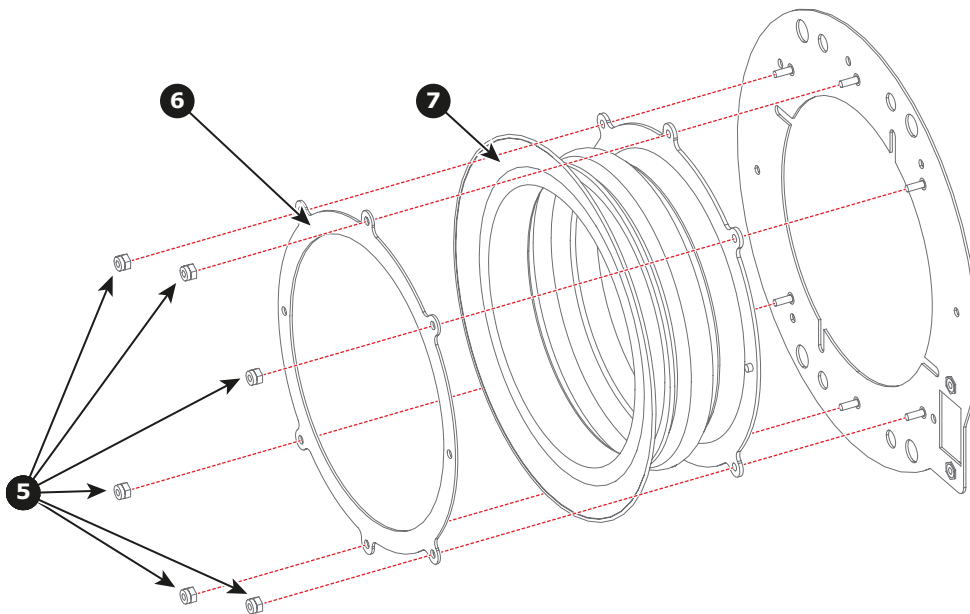

Image 12-43

4. Place the new inner dust rubber (reference 7 image 12-43) over the pins of the new cover. Carefully place the new dust rubber frame (reference 6) of the dust seal over the top of the rubber and over the pins of the new cover. Then use a 5.5 mm nut driver to tighten the dust rubber and dust rubber frame with the six nuts (reference 5).
5. Install the new Lens Holder Cover. Use a PH1 Phillips screwdriver to tighten the seven original screws (reference 3 image 12-42). Make sure you tighten the earth wire (reference 4) back to its original place. Be careful as not to damage the rubber while doing these actions.
6. Carefully reinstall the front plate onto the Lens Holder. Help the rubber through the Lens Holder onto the other side.

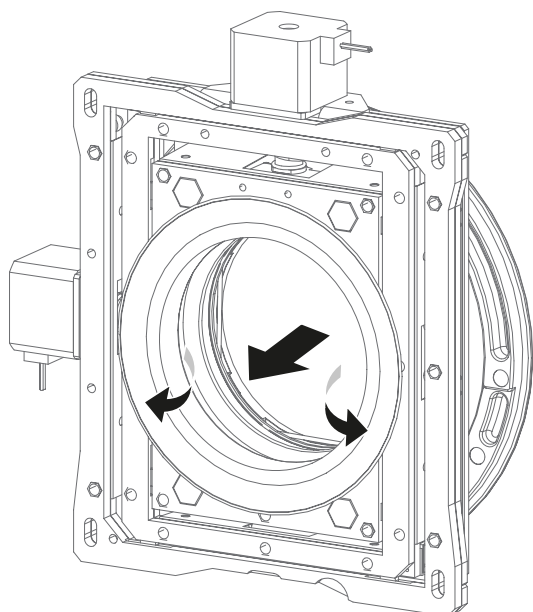

Image 12-44

7. Use a 13 mm nut driver to fasten the four big nuts (reference 2 image 12-41). Fasten the big nuts crosswise bit by bit. Ensure that the upper two rods and the lower left rod contain a big spring.



Proceed with reinstalling the Lens Holder. See procedure "Install the lens holder", page 196.



The Lens Holder has to be adjusted after installation. See procedure "Scheimpflug adjustment", page 199.

13. CARD CAGE

Overview

- Fan controller board
- Integrated Cinema Processor (ICP) board
- HD-SDI board + link decryptor
- Cinema controller board
- Removing a board in the card cage
- Inserting a board in the card cage
- Replacement of the RTC battery of the ICP board
- Battery replacement on the Cinema Controller Board
- Removing the button unit
- Installation of the button unit
- Replacement of the Button module (first generation Keypad)
- Replacement of the Keypad (first generation Keypad)
- Replacement of the Keypad assembly (second generation Keypad)
- Replacement of the signal back plane
- Replacement of the Link Decryptor
- Authorization to clear security warning on the projector
- Replacement of the Status Light

13.1 Fan controller board

Functionalities



Image 13-1
Fan controller board

- Monitors and controls all fans.
- Monitors and controls all voltages provided by the SMPS board.
- Monitors all temperature sensors.
- Controls and monitors the Peltier's on rear of the DMDs.
- Controls the front active cooling.
- Monitors pump speed.
- LEDs on front plate can be used to monitor the output voltages of the SMPS board.
- Drives the dowser (shutter).
- Contains all hardware protections for the projector.
- Controls error line to the LPS and will shut down lamp accordingly.

Conditions included on this board :

- DMD over temperature
- Lamp over temperature
- Lamp cooling down
- Lamp house not connected
- Light processor not connected
- Ambient temperature below 10°C

13.2 Integrated Cinema Processor (ICP) board



In case the projector is equipped with a Barco ICMP no ICP board is inserted. All ICP functionality is integrated in the Barco ICMP.

LEDs and ports on the Integrated Cinema Processor

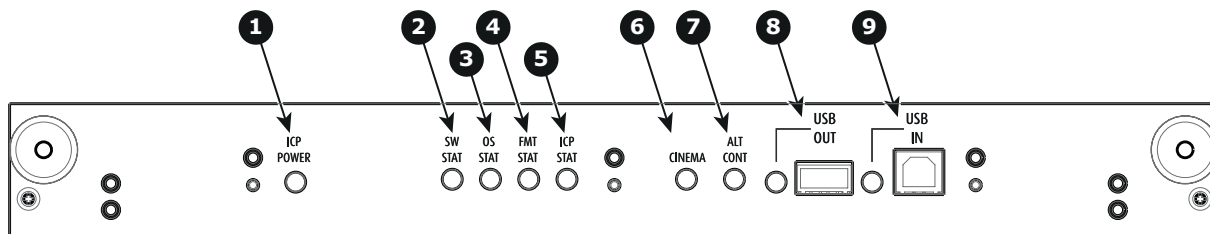

Image 13-2

- 1 ICP is powered.
- 2 ICP software state, normal operation is green blinking.
- 3 ICP operating system state, normally full green .
- 4 ICP FMT configuration state, normally full green.
- 5 ICP MAIN configuration state, normally full green.
- 6 CINEMA port selected. When on, LED 7 will be out.
- 7 ALTERNATIVE port selection. When on, LED 6 will be out. (note that this function is disabled. Led never lights up)
- 8 USB, for future use.
- 9 USB, for future use.

LED diagnostic

| State description | Normal operation | Error state |
|--|------------------|---|
| Software state (LED reference 2) | flashing green | red or orange |
| Operating System state (LED reference 3) | green | off, red or yellow |
| FMT FPGA state (LED reference 4) | green | red : unable to configure the FPGA yellow : FPGA is loaded with the Boot application |
| ICP FPGA state (LED reference 5) | green | red : unable to configure the FPGA yellow : FPGA is loaded with the Boot application |

ICP functions:

- Stores all projector files. When board is replaced; clone package must be reloaded.
- Stores and generates test patterns.
- Scaling to native resolution, re-sizing, masking, line-insertion de-interlacing, subtitle overlay, color space conversion, de-gamma, color correction
- Source Selection between alternative content and cinema content.
- Stores a Certificate and Private Key needed for Playback validation
- Contains a real time clock, which must be synchronized with the GMT/UTC time stored in the link decryptor module or Integrated Media Block (see Communicator software)
- Handles unpacking of special video formats



The ICP board spare part kit is programmed specifically for DP2K-C series projectors. When installing an ICP board in other types of projectors, the software must be reinstalled after installation. See chapter "ICP software upgrade", page 263.



When installing a new ICP board, the Spatial Color Calibration file must be reloaded and activated. See chapter "Activate Spatial Color Calibration file", page 163.



CAUTION: Make sure not to short circuit the battery on the board. That will destroy the board completely !

13.3 HD-SDI board + link decryptor

Functionality



Image 13-3
HD-SDI + Link Decryptor

- Converts all HD/SDI video formats to ICP compliant pixel mapping
- Contains 7 Full-HD test patterns (e.g. Color Bars, H-Ramp, Moiré, ...)
- Decryption of Cinelink-2 encrypted content
- Permanent Security monitoring (with battery back-up) : intrusion detection; voltage monitoring; temperature monitoring; security switches; build in self test; ...
- Handles communication with content servers.
- Contains a real time clock (GMT/UTC time); a Certificate and a Private Key
- Battery shelf life: 6 months

Replace board

To replace the board, follow the procedure as described in *Replacement of a Card Cage board*. Remove the Link decryptor as described in *Replacement of the Link Decryptor*

Place the link decryptor on the new board and insert the assembly in the Card Cage.

13.4 Cinema controller board

Functionality



Image 13-4
Cinema controller board

- Ethernet Communication to ICP, Media block or Link decryptor.
- Two DVI ports (with HDCP) for alternative content.
- RS232 port to BARCO Controller.
- Standardized 3D interface on board.
- GPIO controls
- Peripheral Port
- Lensholder motors (stepper motors)
- Stores lens files and lens type / Controls lens
- Lens motor drivers (DC motors)
- Stores Dallas key
- Controls lamp power supply
- Stores SNMP key
- Stores Barco IP address and host name
- Handles reporting of errors, version info & Barco logs to Communicator
- Controls ICP board
- Controls Dolby 3D color wheel
- Controls and monitors keypad
- Controls and monitors status lights
- Stores Macro, Input, Lens file, 3D file and LSC file.



Prior to replace the Cinema Controller board try to read out the SNMP key. Use for that the Communicator software. In case it is not possible to read out the SNMP key a new SNMP key has to be requested. See chapter "Request for new SNMP key" in the user guide of the Communicator software.



When inserting a new Cinema Controller board the SNMP key must be reprogrammed in the new board and the Dallas key must be re-identified with the new board. See user guide Communicator for precise instructions.

Ethernet network communication

The DP2K-12C/11CX projector can be connected to a LAN (local area network) using one of the 10/100/1000 base T ports on the communication interface. Once connected to the LAN, users are capable of accessing the projector from any location, inside or outside (if allowed) their company network using the control software (Communicator touch panel). This toolset locates the projector on the network in case there is a DHCP server or the user can insert the correct IP-address of the projector to access the projector. Once accessed, it is possible to check and manipulate all the projector settings. Remote diagnostics, control and monitoring of the projector can then become a daily and very simple operation. The network connectivity permits to detect potential errors and consequently improve the time to servicing.

As there is a need to daisy chain projectors when they are in Ethernet network, an Ethernet switch is build in, the incoming network is hereby available for the internal PC and for the next device in the chain. In this way a 'star' network interconnection can be avoid. The switch used is a stand alone 10/100Mbit Ethernet switch. This assures no influence on the network speed. Whenever a slow (10Mbit) device is connected the speed between the 100Mbit devices remains 100Mbit.

Both Ethernet ports are equipped with a yellow and a green LED. The yellow LED lights up in case the port is connected with a 100Mbit network. The green LED blinks in case there is network activity.



The connectors used for both Ethernet ports are of the type RJ45, which is compatible with standard RJ45 cable connector. Straight (most common) as well as cross linked network cables can be used. The 2 ports are functionally identical. Both ports are connected via the projector hub (Auto sensing enabled).

RS232 serial communication

The communication interface of the DP2K-12C/11CX supports RS232 serial communication. You can use the RS232 input port to connect a local PC to your DP2K-12C/11CX projector. This way you can configure and control your DP2K-12C/11CX projector from your local PC.



Do not forget to set the projector's baud rate (default = 115200) to match that of the computer.

Advantages of using RS232 serial communication:

- easy adjustment of the projector via PC (or MAC).
- wide range of control possibilities.
- address range from 0 to 255.
- sending data to the projector (update).
- copying data from the projector (backup).



RS232

An Electronic Industries Association (EIA) serial digital interface standard specifying the characteristics of the communication path between two devices using either D-SUB 9 pins or D-SUB 25 pins connectors. This standard is used for relatively short-range communications and does not specify balanced control lines. RS-232 is a serial control standard with a set number of conductors, data rate, word length and type of connector to be used. The standard specifies component connection standards with regard to computer interface. It is also called RS-232-C, which is the third version of the RS-232 standard, and is functionally identical to the CCITT V.24 standard. Logical '0' is $> +3V$, Logical '1' is $< -3V$. The range between $-3V$ and $+3V$ is the transition zone.

GENERAL PURPOSE IN/OUT (GPIO)

This female 37 pins D-SUB connector can be used to send or receive trigger signals from other devices. These input/output pins can be programmed by macros created via the Communicator touch panel. See user's guide of the Touch panel, section Macro editor, for more information about this functionality.

13.5 Removing a board in the card cage

About the procedure

The same procedure can be used to replace one of the following boards:

- Fan controller board
- Integrated cinema processor board
- HD-SDI board + Link Decrypter
- Cinema controller board



CAUTION: Wear a wrist band which is connected to the ground while handling the electrostatic discharge sensitive parts.

Necessary tools

Phillips screw driver

How to replace a board

1. Remove the input cover.
2. Turn out both fixation screws (1).

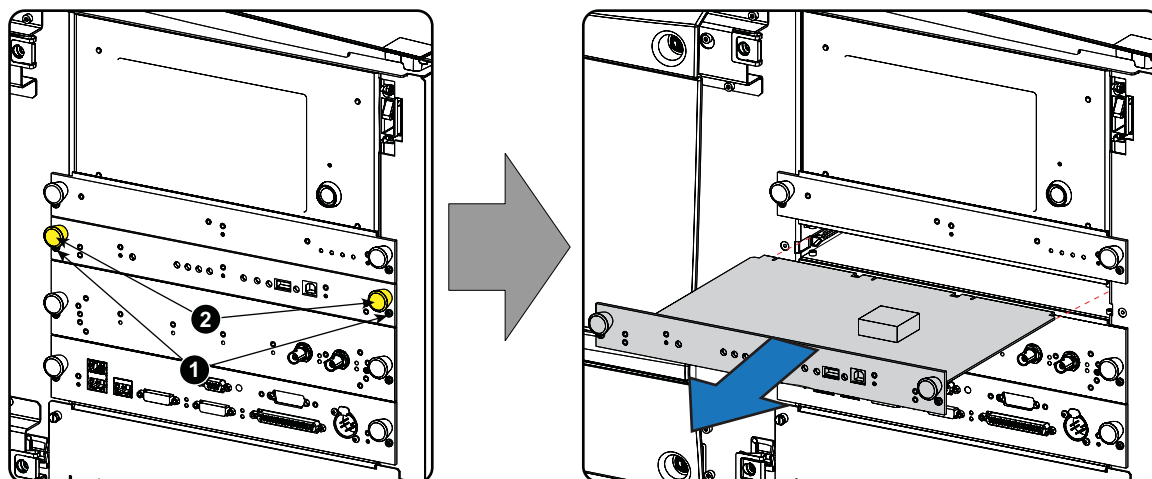

Image 13-5
Removal of a board

3. Take the board by both handles (2) and pull it out.

All connections are made via the board to board connection with the back plane.

13.6 Inserting a board in the card cage



CAUTION: Wear a wrist band which is connected to the ground while handling the electrostatic discharge sensitive parts.

Necessary tools

Phillips screw driver

How to insert

1. Take the board by both handles (2).

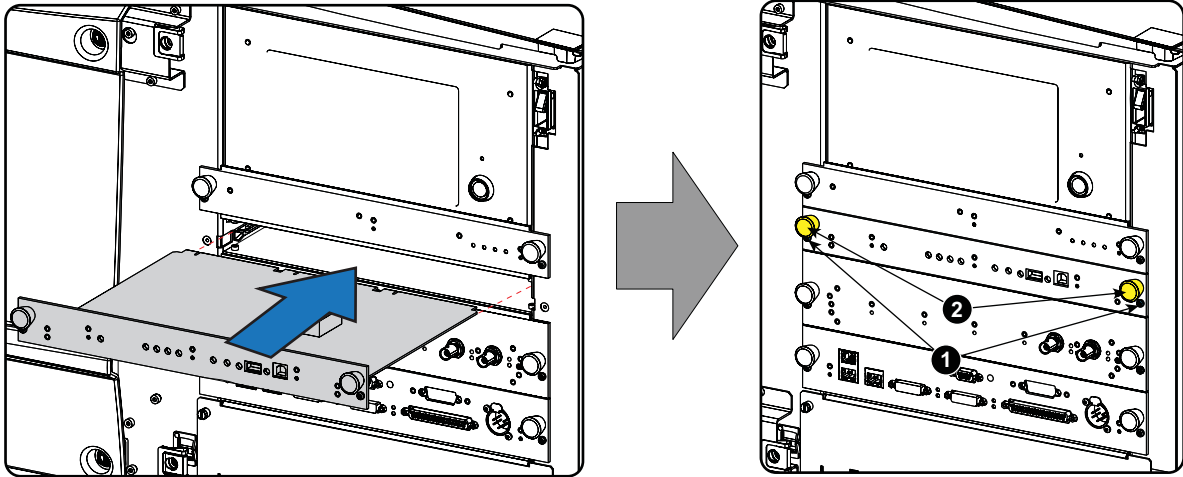

Image 13-6
Insertion of a board

2. Slide the board into both grooves.
3. Push on both handles until the board is fully inserted and the connection is made with the back plane.
4. Secure the board by turning in both fixation screws (1).



When inserting a new ICP board in the card cage, the ICP software must be re-installed. See "Software update via Communicator (DC update companion)", page 255.

13.7 Replacement of the RTC battery of the ICP board

Necessary tools

Phillips screw driver

Necessary parts

All parts are included in kit R8766526K (battery cover, coin cell battery BR2330 and a pair of gloves).

How to replace

1. Put on the gloves.
2. Remove the ICP board from the card cage. See chapter "Removing a board in the card cage".
3. Carefully put the ICP board on a table.
4. Place the battery cover over battery 'B2' of the ICP board to protect this battery while replacing the RTC battery 'B1' which is seated in the battery holder.

Note: The battery cover can be left on the board.

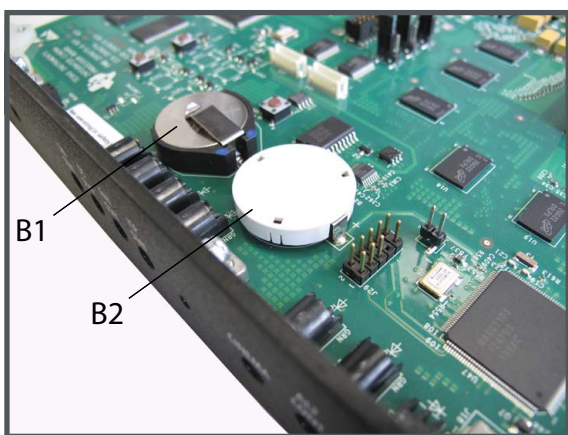

Image 13-7

5. Remove the RTC battery 'B1' from the battery holder and insert the new battery in the battery holder.

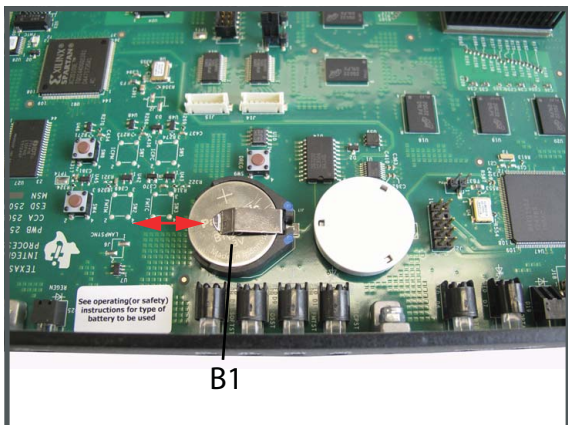

Image 13-8

6. Insert and fixate the ICP board back in the card cage. See chapter "Inserting a board in the card cage".
7. Power on the projector.
8. Clear the projector error 5800 "ti-icp - system status = fail" with error message "ICP real time clock error" by configuring the RTC (Real Time Clock) of the ICP. See user manual Communicator chapter "Set up of the ICP clock", choose the option UTC/GMT time calculated from current PC time as current time.

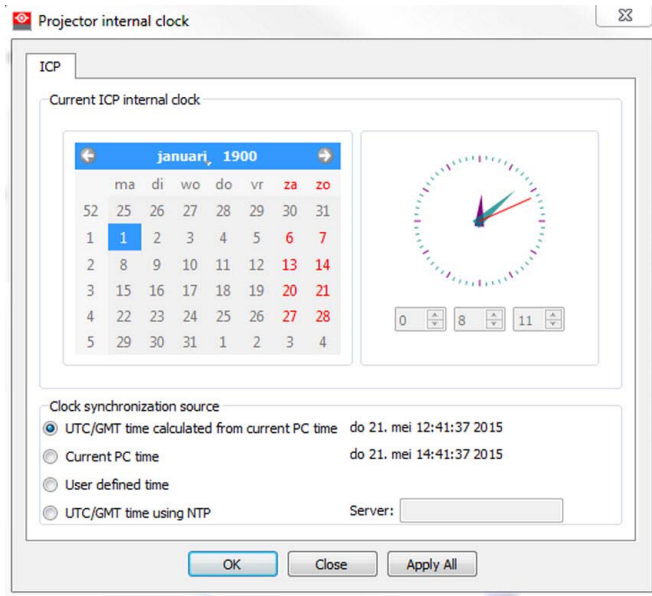

Image 13-9

9. Clear the projector error 5834 “physical marriage tamper event” by remarrying the projector. See service manual chapter “Authorization to clear security warning on the projector”.

13.8 Battery replacement on the Cinema Controller Board

About an empty battery

There is no error indication in Communicator when the battery is almost empty. Only when opening the error logging after powering on the projector, you will see that some time stamps in the beginning of the list are missing or that these time stamps are still old timings. That is due to an empty battery on the Cinema Controller Board.



There is no battery kit available. The customer has to buy a new battery himself.

Battery type used : CR1220 (3V, 0.03AH, Li)

Necessary tools

PH2 Phillips screwdriver.

Necessary parts

Battery CR1220

How to replace

1. Loosen the two screws (reference 1) at the front of the Cinema Controller.
2. Pull the Cinema Controller out of its compartment.
3. Pull out the empty battery and insert a new CR1220 battery with the flat side of the battery facing to the top.
Note: No battery kit available as spare part. Buy a new one in a dedicated shop.

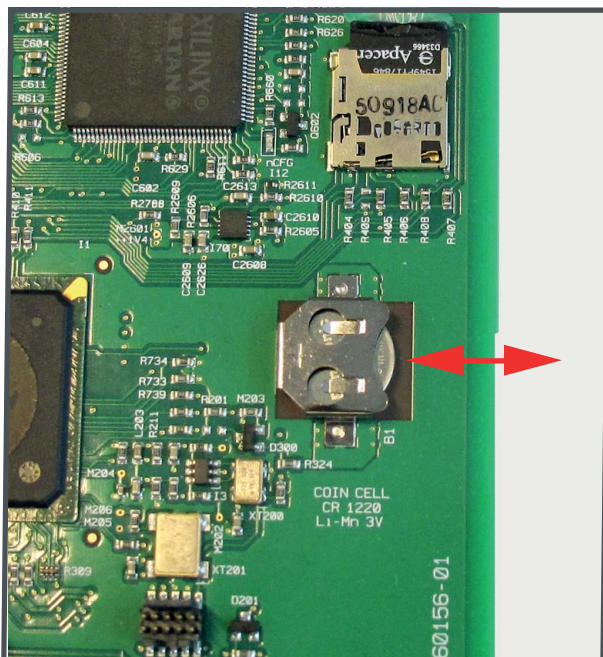

Image 13-10
Battery replacement

4. Gently insert the Cinema Controller in the guides of the Cinema Controller compartment as illustrated. Push it completely in.
Caution: Ensure that the both sides of the Cinema Controller are captured by the guides inside the Cinema Controller compartment, as shown in the detail of the illustration.
5. Fasten the two screws at the front side of the Cinema Controller (reference 1).

13. Card Cage

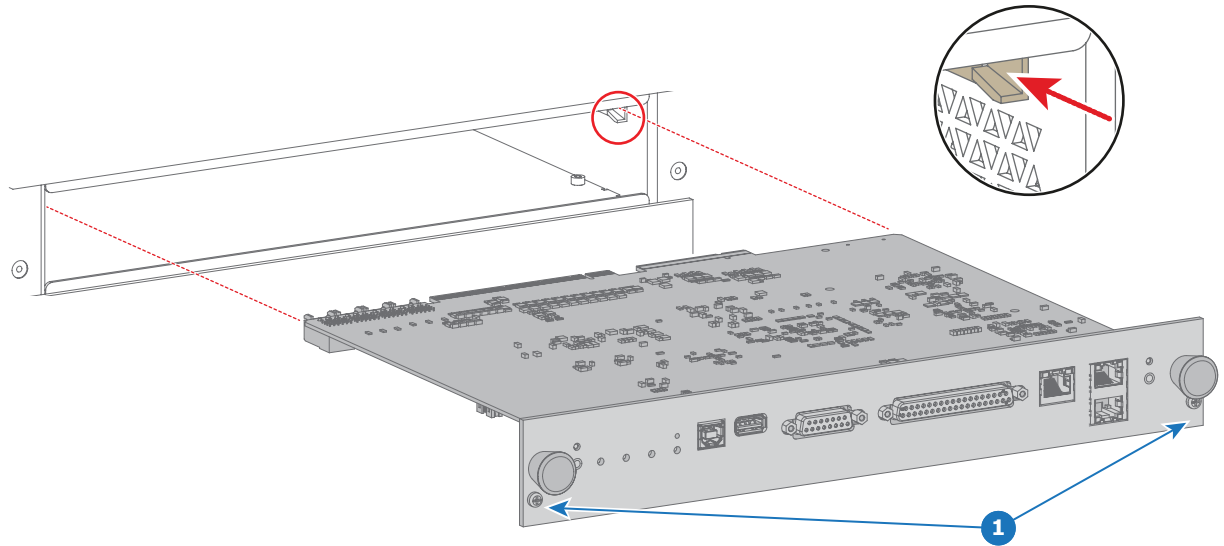

Image 13-11

13.9 Removing the button unit

Preparations

Before starting with the replacement of the button unit, remove first:

- Side covers and top cover, see Removal and Installation of the projector covers.
- Light processor top cover (Convergence cover plate).

Necessary tools

- Allen wrench 3 mm
- Phillips screw driver

How to remove

1. Unplug the wire unit at the backside of the button unit.

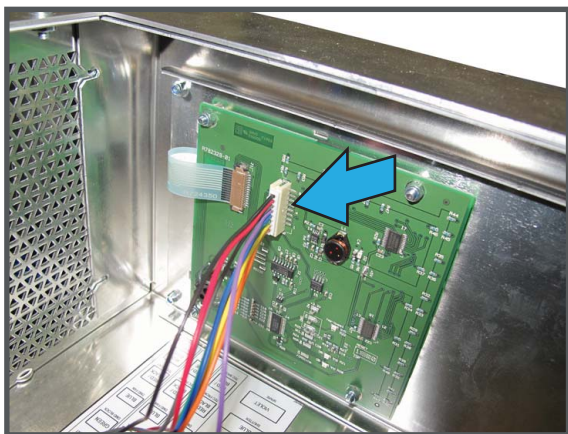

Image 13-12
Button unit, connections

2. Pull out all the cable from the cable holders.

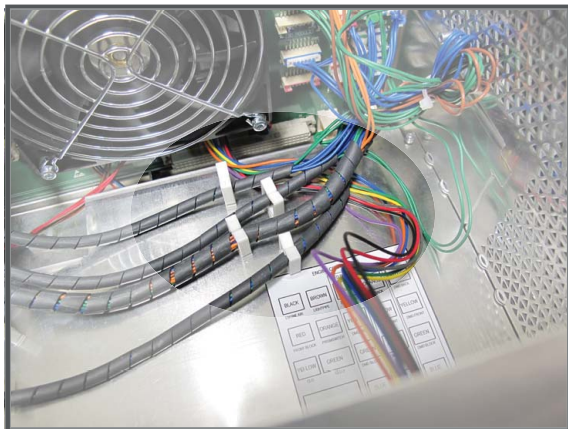

Image 13-13
Button unit, cable holders

3. At the inner side, loosen both hexagon screws at the left side of the button unit (1).

13. Card Cage

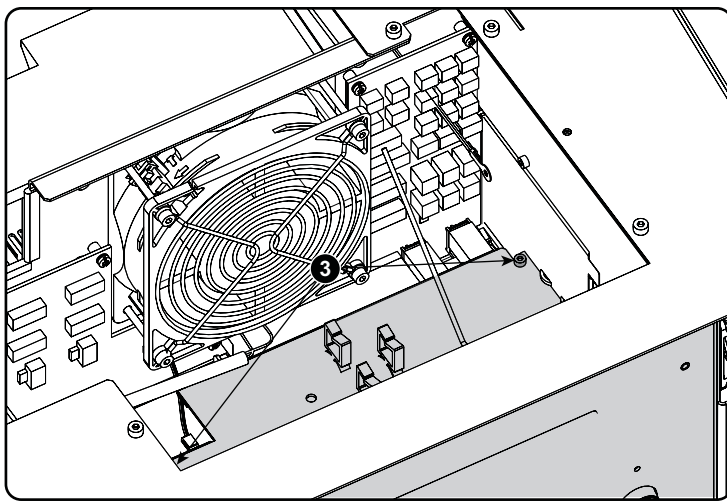
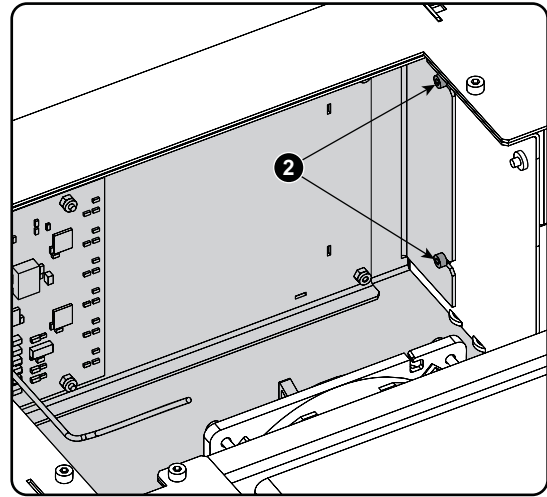
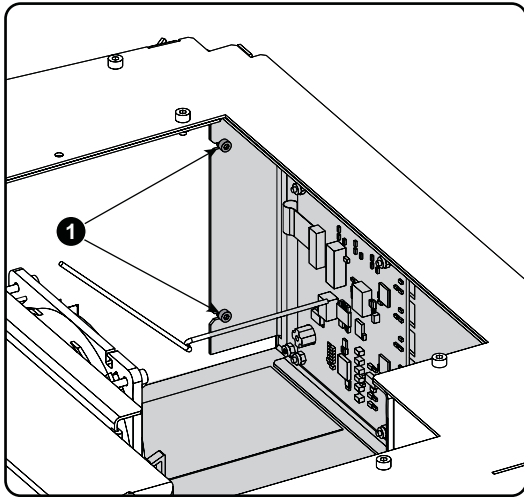

Image 13-14
Button unit fixations

4. Loosen also both hexagon screws at the right side (2).
5. Loosen both screws at the bottom plate (3) of the button unit.
6. Loosen the fixation screws of the fan controller board and pull the board a little out.
7. Slide out the button unit.

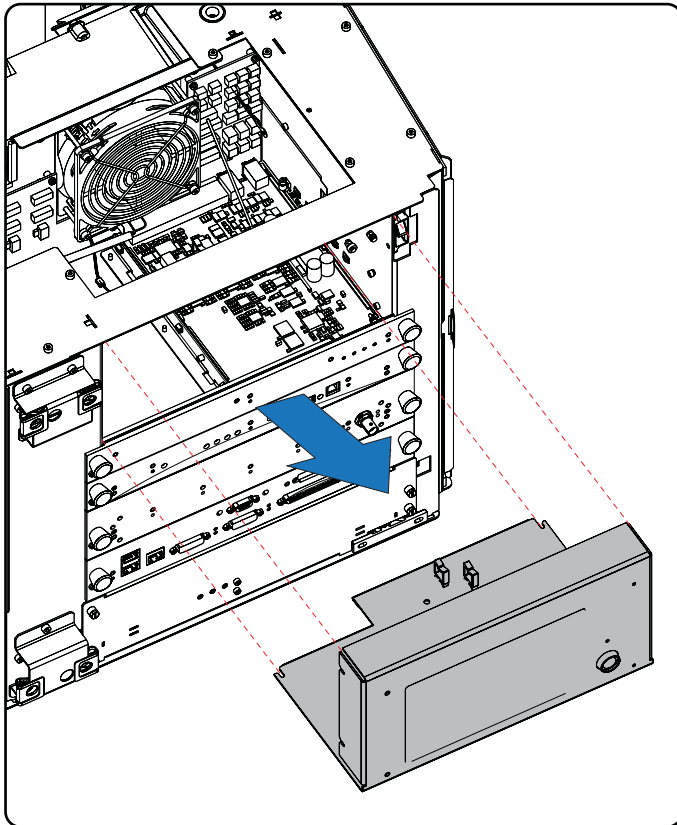

Image 13-15
Button unit removal

13.10 Installation of the button unit

How to install

1. Insert the button module so that the bottom plate of the unit fits into the support grooves at both sides of the card cage.

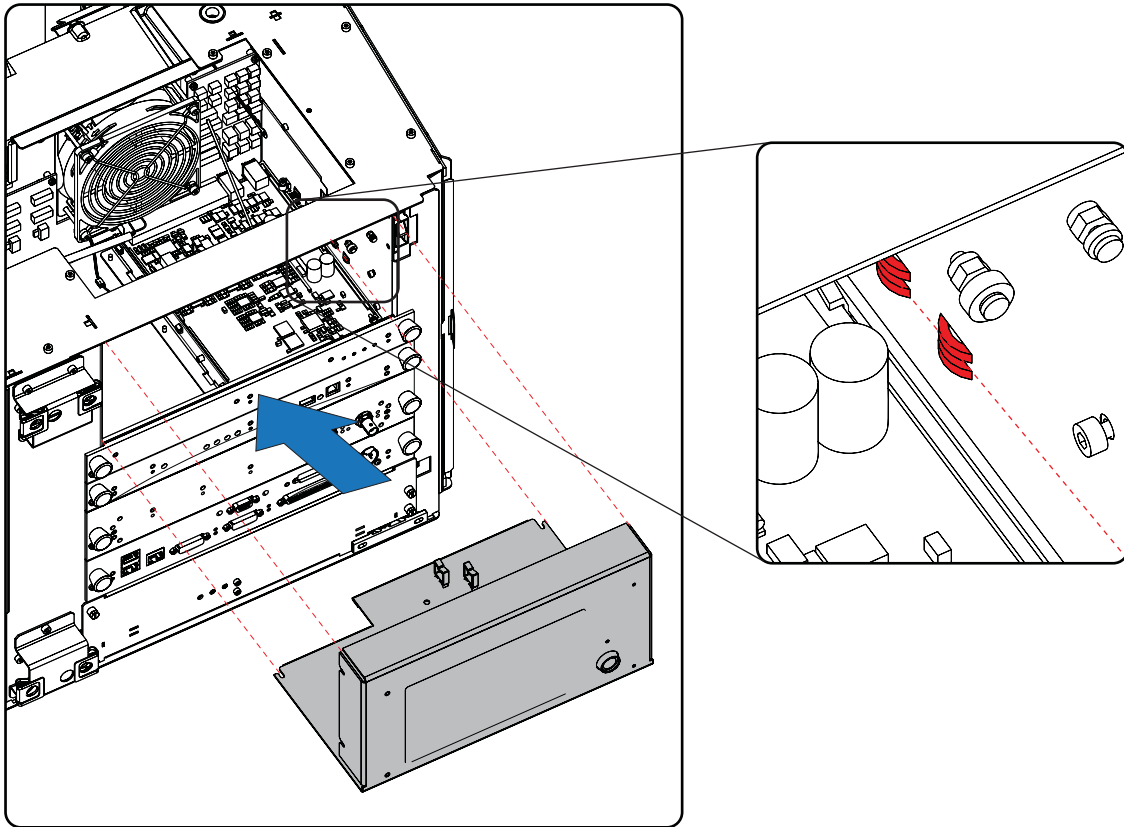

Image 13-16
Button unit, installation

2. Slide in the unit until it is completely inserted.
Note: *The front of the unit must be equal with the front of the card cage.*
3. Secure its position by driving in:
 - both fixation screws at the bottom plate of the unit (3).
 - both fixation screws at the left (1) and the right side of the unit (2).
4. Reconnect the wire unit with the back side of the button unit.
5. Secure the cables by pushing them back in the cable holders.

13.11 Replacement of the Button module (first generation Keypad)



This procedure assumes that the Button assembly is already removed from the Card Cage.

Necessary tools

5.5 mm nut driver

How to replace the Button module?

1. Disconnect the flat cable (reference 1, image 13-17) from the Button module (reference 2, image 13-17) by performing the following procedure:
 - a) Pull out the locks at both sides of the socket (step 2, image 13-18).
 - b) Pull out the flat cable from the socket (step 3, image 13-18).

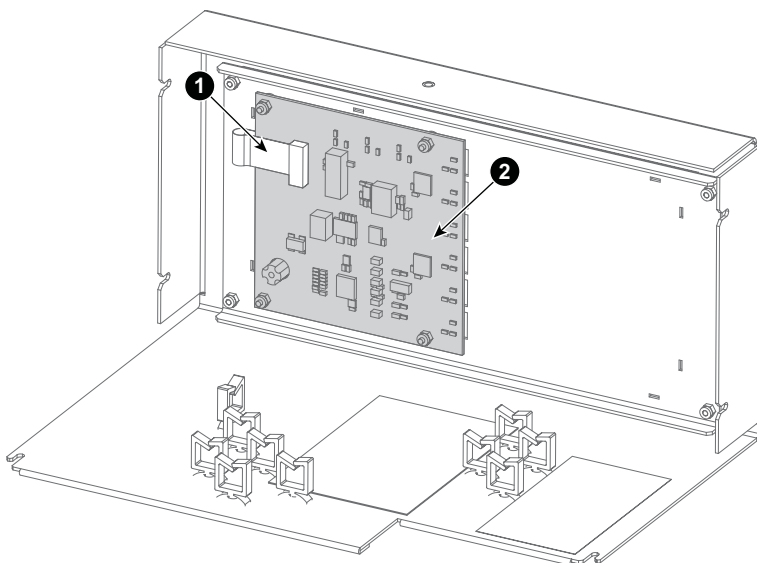

Image 13-17

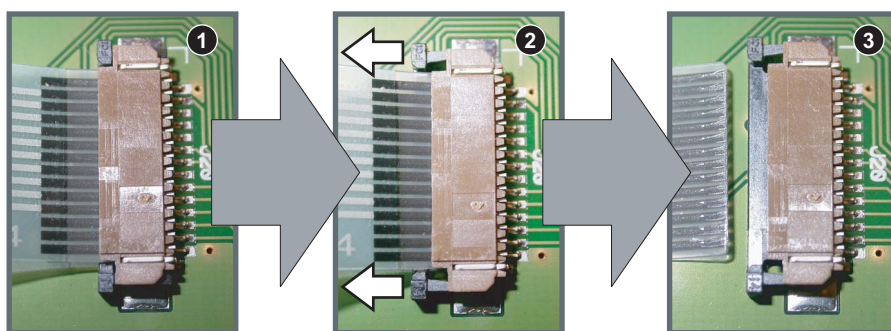

Image 13-18

2. Remove the 4 lock nuts (reference 3, image 13-19) from the Button module mounting bolts.

13. Card Cage

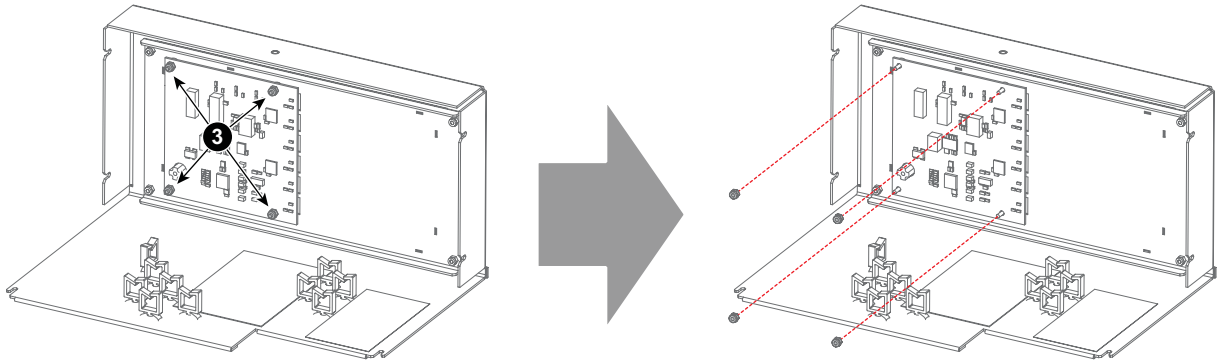

Image 13-19

3. Remove the Button module (reference 4, image 13-20).

Tip: Make sure the 4 washers (reference 5, image 13-20) don't drop off the Button module mounting bolts.

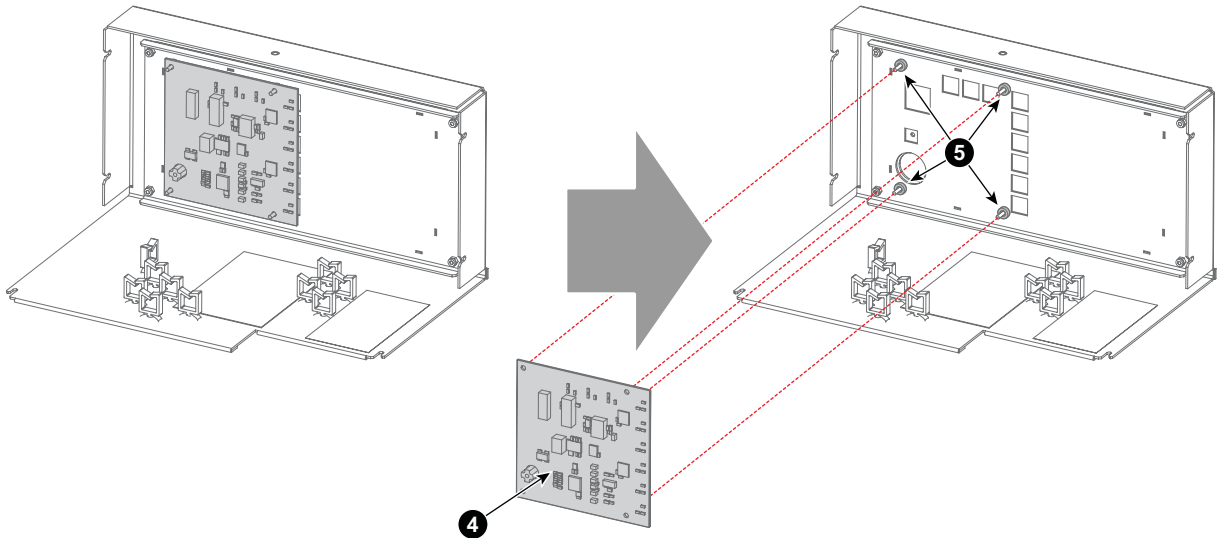

Image 13-20

4. Install the new Button module (reference 6, image 13-21).

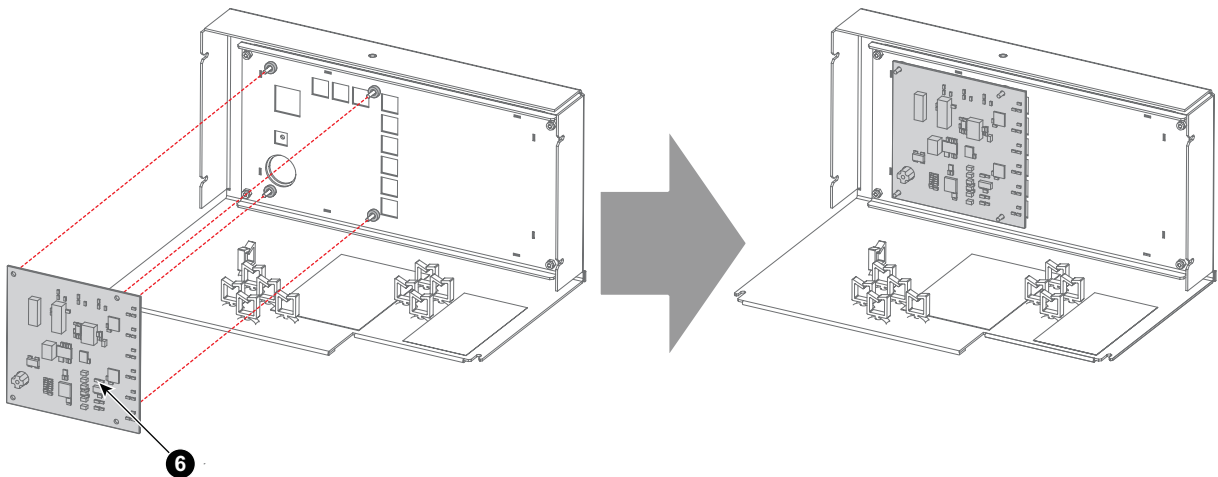

Image 13-21

5. Tighten the 4 lock nuts (reference 7, image 13-22) on the Button module mounting bolts.

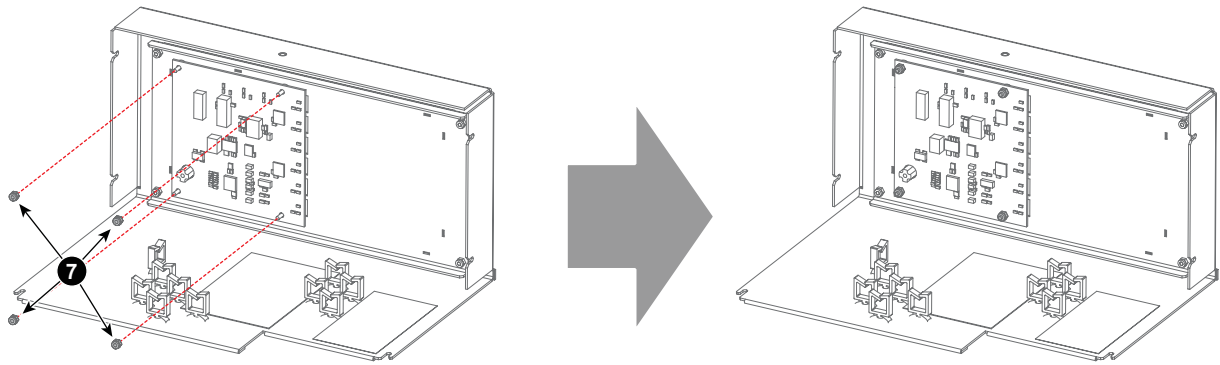

Image 13-22

6. Connect the flat cable to the Button module by performing the following procedure:
- Make sure the locks at both sides of the socket are pulled out (step 1, image 13-23).
 - Insert the flat cable into the socket (step 2, image 13-23).
 - Lock the flat cable by pushing in the locks at both sides of the socket (step 3, image 13-23).

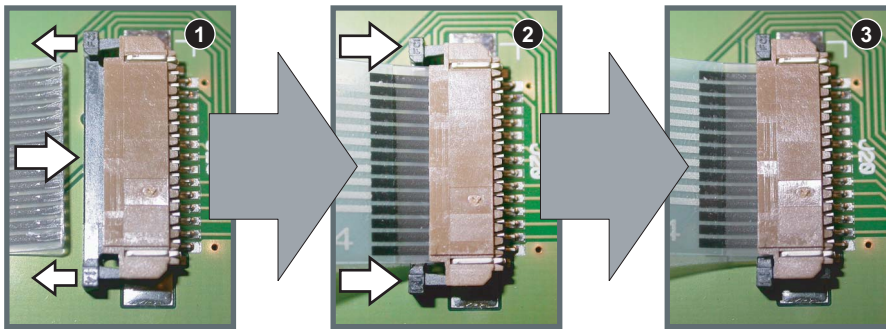

Image 13-23

13.12 Replacement of the Keypad (first generation Keypad)



This procedure assumes that the Button assembly is already removed from the Card Cage.

Necessary tools

5.5 mm nut driver

How to replace the Keypad?

1. Disconnect the flat cable (reference 1, image 13-24) from the Button module (reference 2, image 13-24) by performing the following procedure:
 - a) Pull out the locks at both sides of the socket (step 2, image 13-25).
 - b) Pull out the flat cable from the socket (step 3, image 13-25).

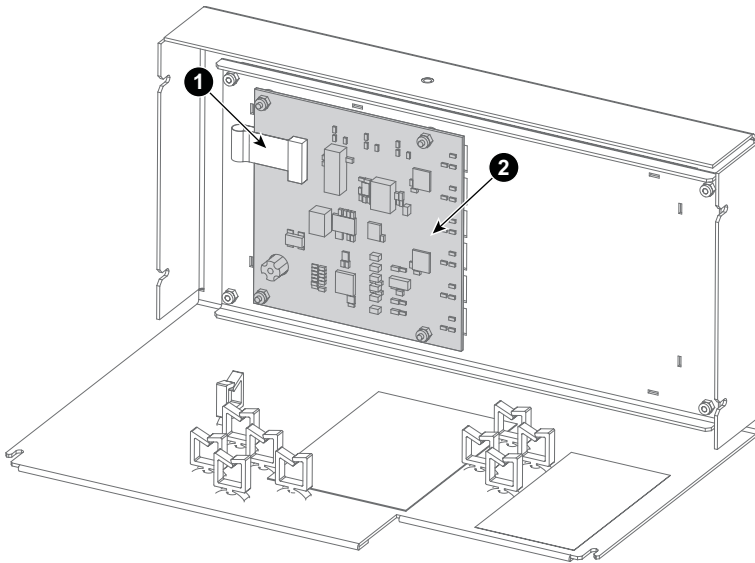

Image 13-24

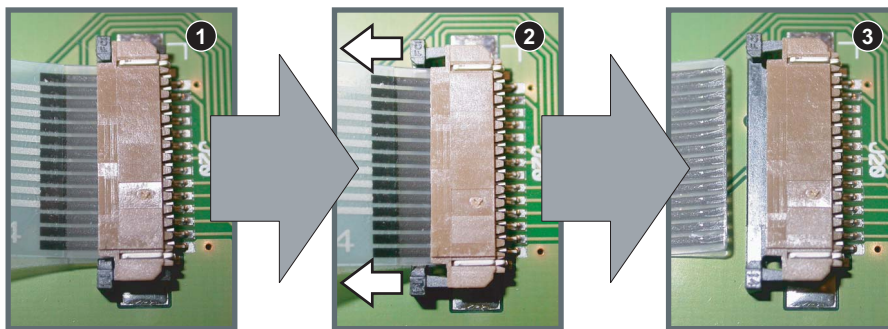

Image 13-25

2. Remove the 4 lock nuts (reference 3, image 13-26) from the Button module mounting bolts.

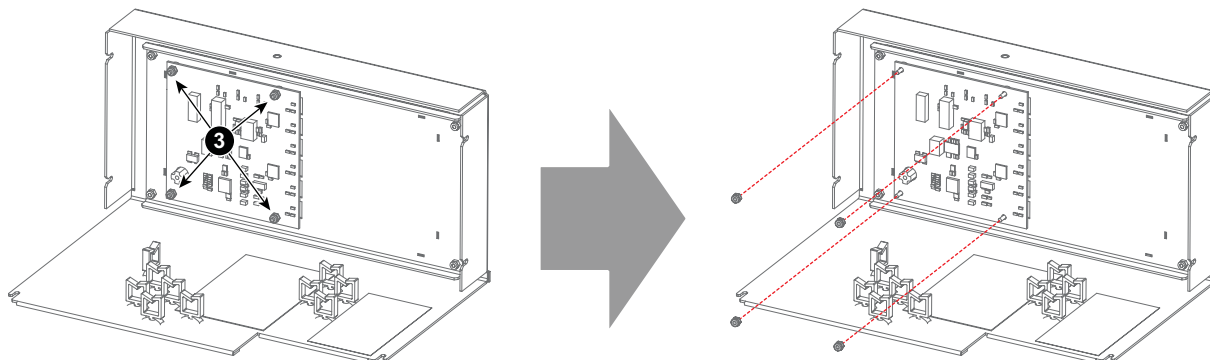

Image 13-26

3. Remove the Button module (reference 4, image 13-27) and the 4 washers (reference 5, image 13-27) from the Button module mounting bolts.

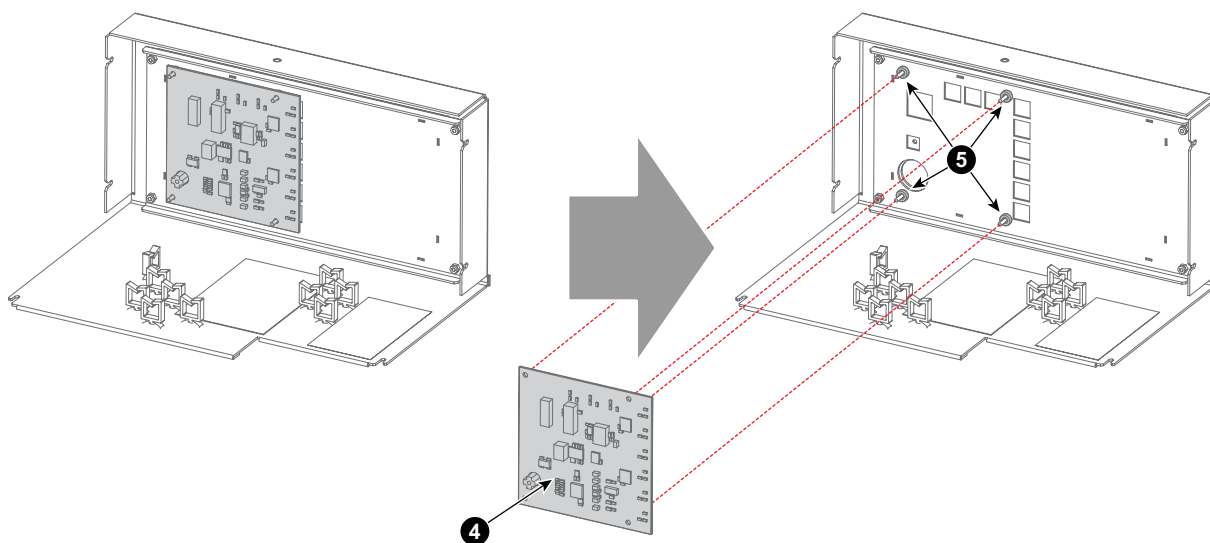

Image 13-27

4. Remove the 4 lock nuts (reference 6, image 13-28) from the Keypad mounting bolts.

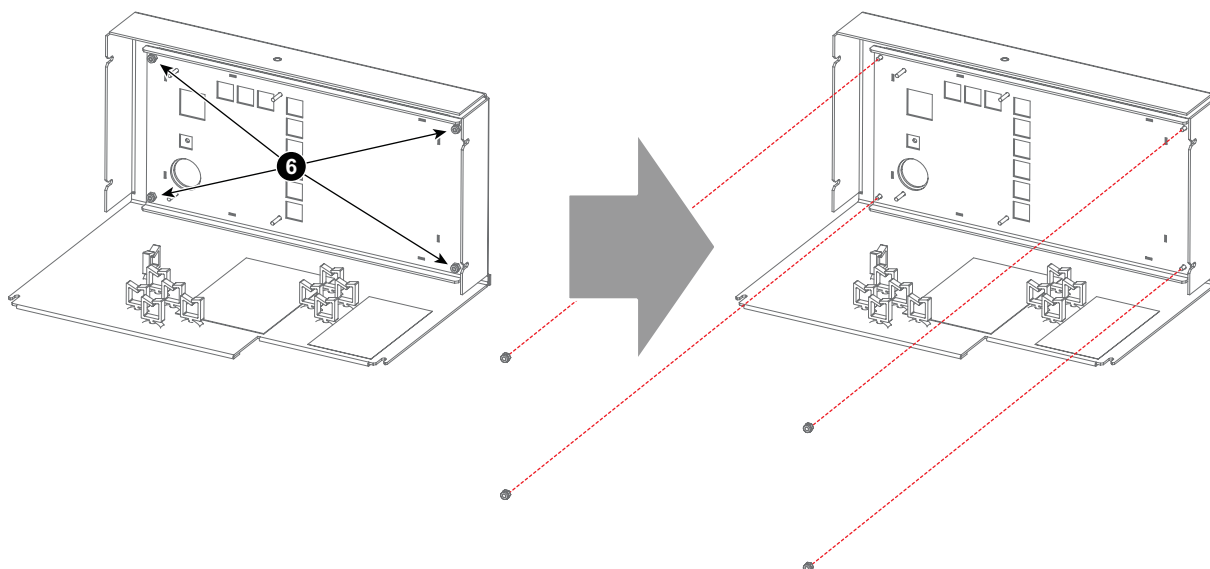

Image 13-28

5. Remove the Keypad (reference 7, image 13-29).

Tip: Make sure the 4 washers (reference 8, image 13-29) don't drop off the Keypad mounting bolts.

13. Card Cage

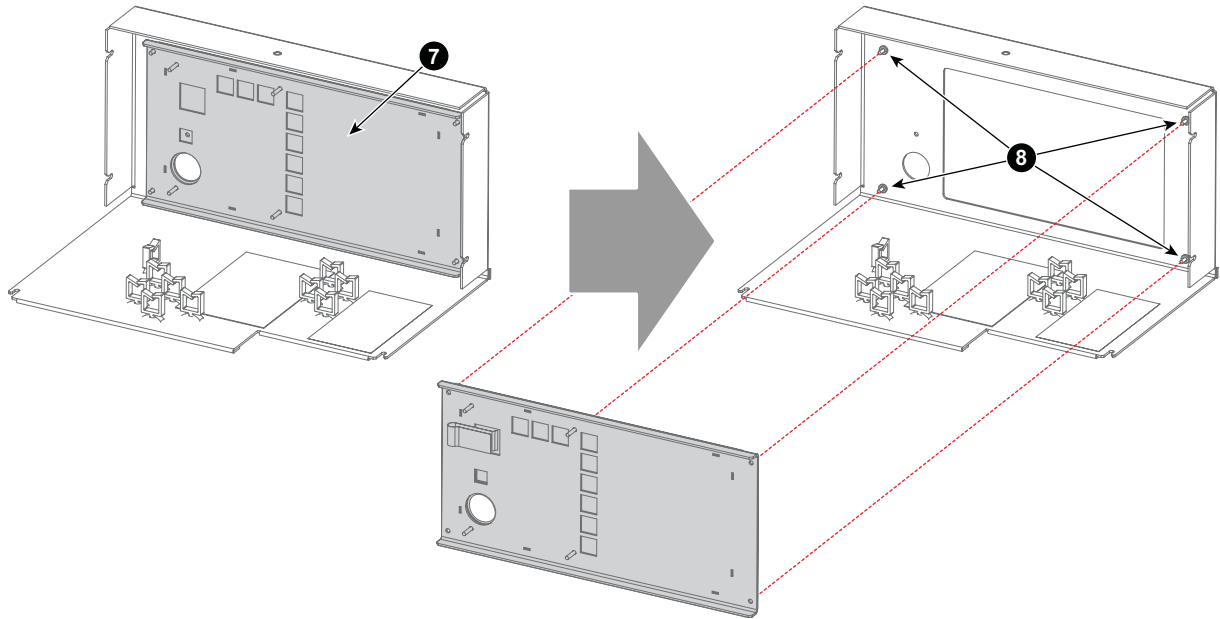

Image 13-29

6. Install the new Keypad (reference 9, image 13-30).

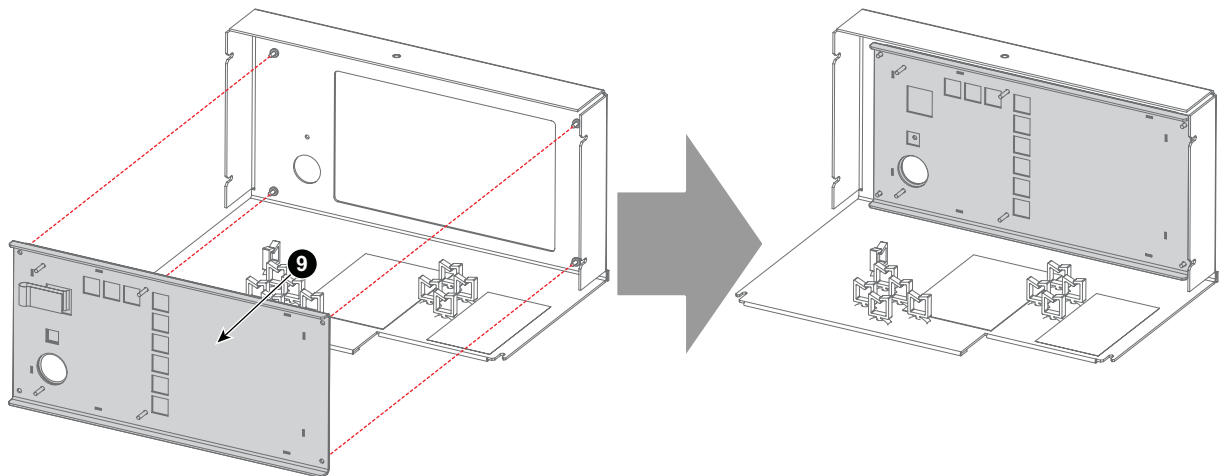

Image 13-30

7. Tighten the 4 lock nuts (reference 10, image 13-31) on the Keypad mounting bolts.

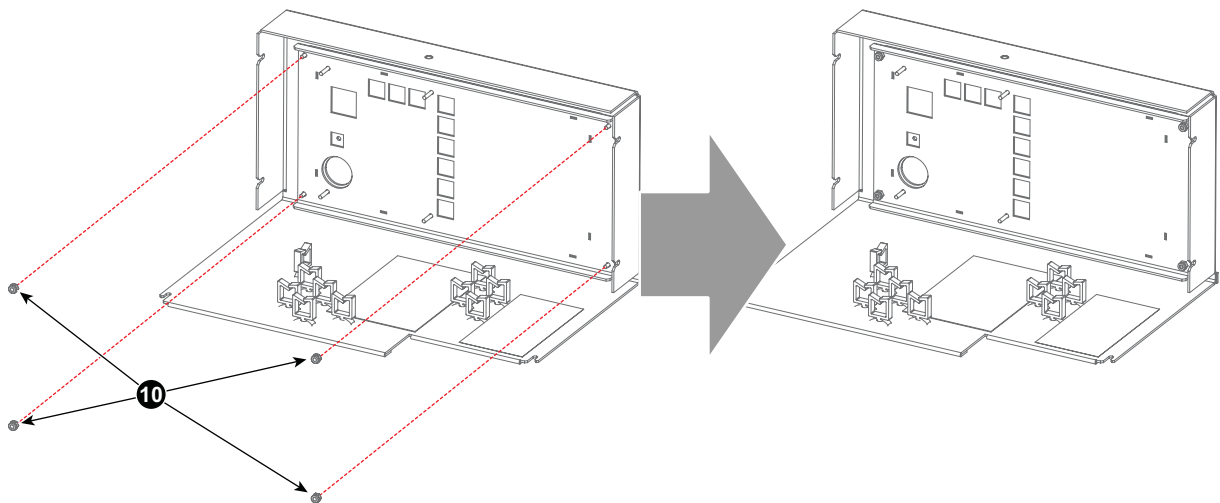

Image 13-31

8. Install the new Button module (reference 11, image 13-32).

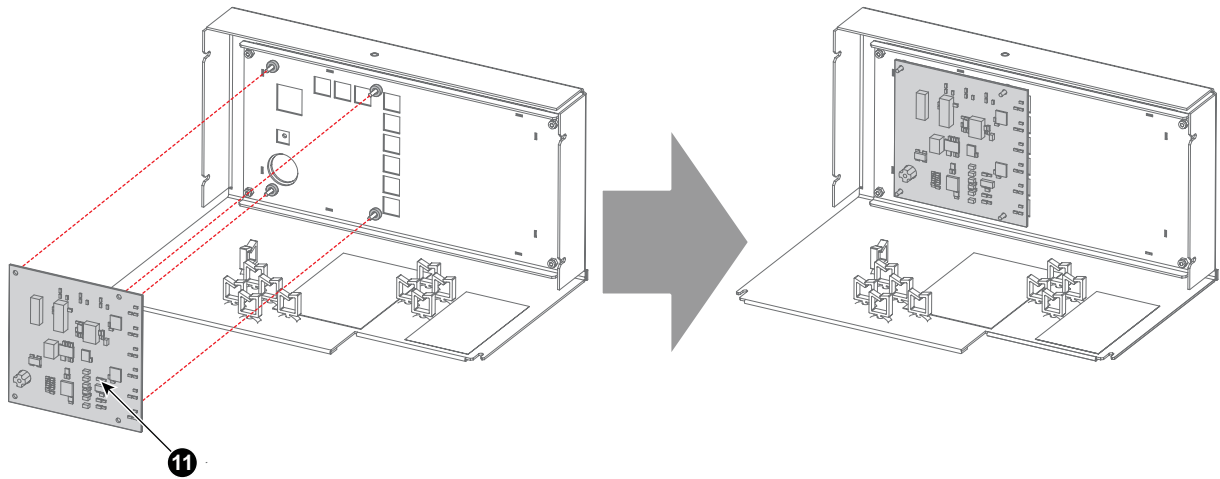

Image 13-32

9. Tighten the 4 lock nuts (reference 12, image 13-33) on the Button module mounting bolts.

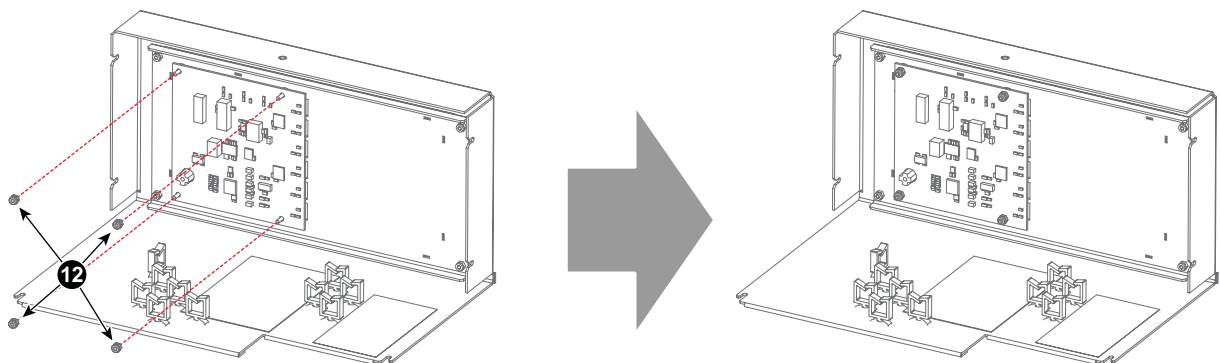

Image 13-33

10. Connect the flat cable to the Button module by performing the following procedure:

- a) Make sure the locks at both sides of the socket are pulled out (step 1, image 13-34).
- b) Insert the flat cable into the socket (step 2, image 13-34).
- c) Lock the flat cable by pushing in the locks at both sides of the socket (step 3, image 13-34).

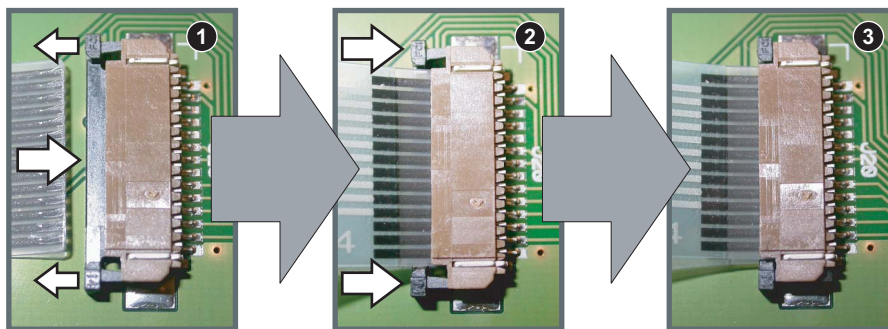

Image 13-34

13.13 Replacement of the Keypad assembly (second generation Keypad)

How to replace the Keypad assembly?

1. Remove the 4 lock nuts (reference 1, image 13-35) from the Keypad assembly mounting bolts.
2. Remove the Keypad assembly (reference 2, image 13-35).
Tip: Make sure the four washers (reference 3, image 13-35) don't drop off the keypad assembly mounting bolts.
3. Install the new Keypad assembly (reference 2, image 13-35).
4. Tighten the 4 lock nuts (reference 1, image 13-35) on the Keypad assembly mounting bolts.

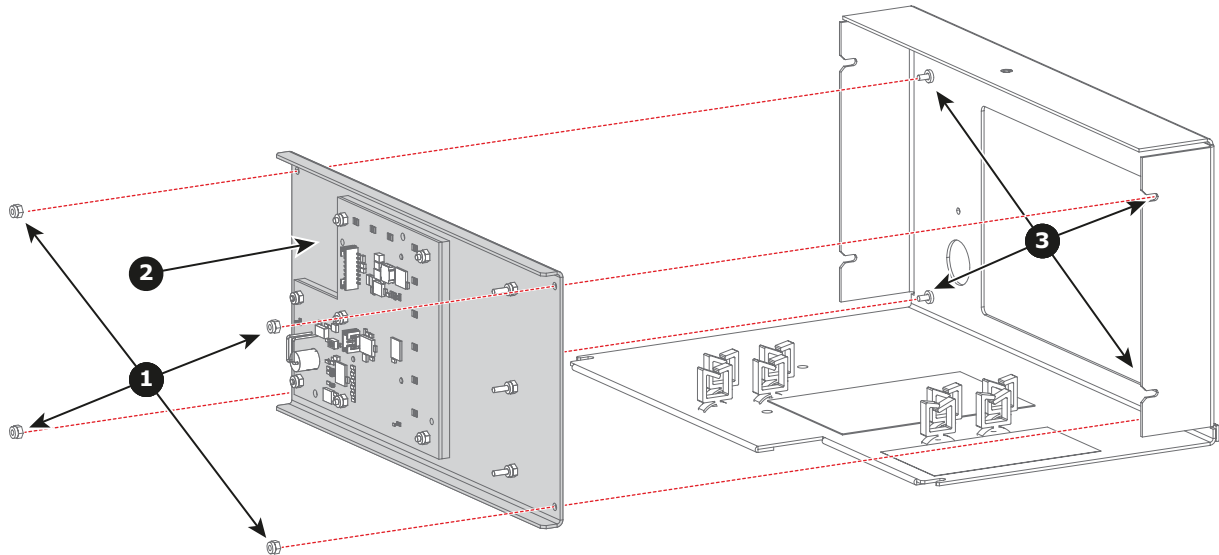

Image 13-35

13.14 Replacement of the signal back plane

About the Signal back plane

- Provides direct connection between all components listed below:
 - Fan Controller
 - Integrated Cinema Processor
 - HD-SDI Board
 - Cinema Controller
 - ID card
- All DC voltages are passed through this board from SMPS board to final board / module.
- Provides cable connection between all components listed below:
 - SMPS board
 - Pump
 - Lens motors and lens holder
 - Light processor
 - CLO sensor
 - Dolby 3D controller
 - Fans
 - Security switches
 - Temperature sensors
 - Touch panel
 - Keypad
 - Prism switch sensor
 - Dowser

Necessary tools

- Flat blade screwdriver
- Allen key 2.5 mm

Preparations

1. Remove the front, input cover and top cover, see Removal and Installation of the projector covers.
2. Remove the convergence cover plate as follow:
 - a) Loosen both screws (reference 1 and 2).
 - b) Slide the plate forwards until all hooks at both sides of the plate become free.
 - c) Take off the plate.

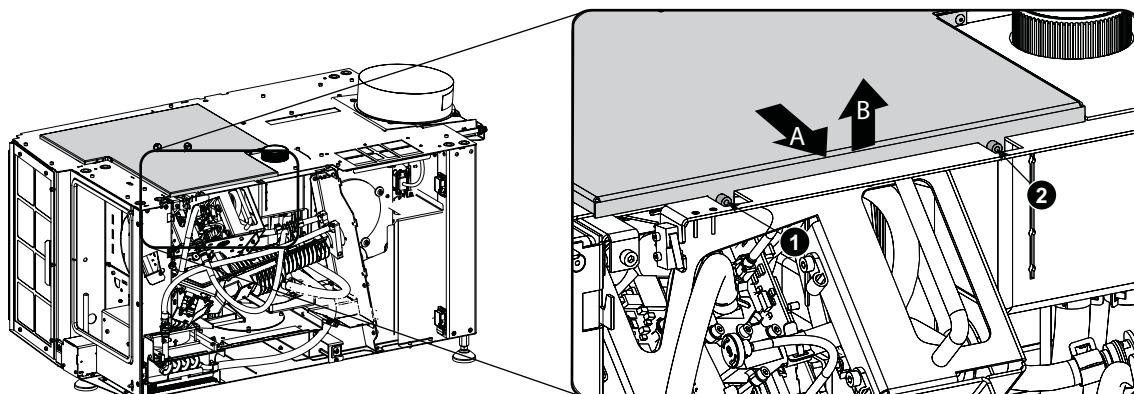

Image 13-36
Convergence cover plate

3. Remove the button panel assembly, "Removing the button unit", page 227.

Remove :

- the fan controller board.
 - Integrated cinema controller board
 - the HD-SDI board
 - Cinema controller board
4. Pull the small handle a little backwards and then to the front of the projector until the filter frame is released and slide out the filter.

Removing the signal backplane

1. Remove the first intermediary plate as follow:
 - a) Unplug the fan connection from the signal backplane (1).
 - b) Turn out both fixation screws (2).
 - c) Slide out the plate (3).

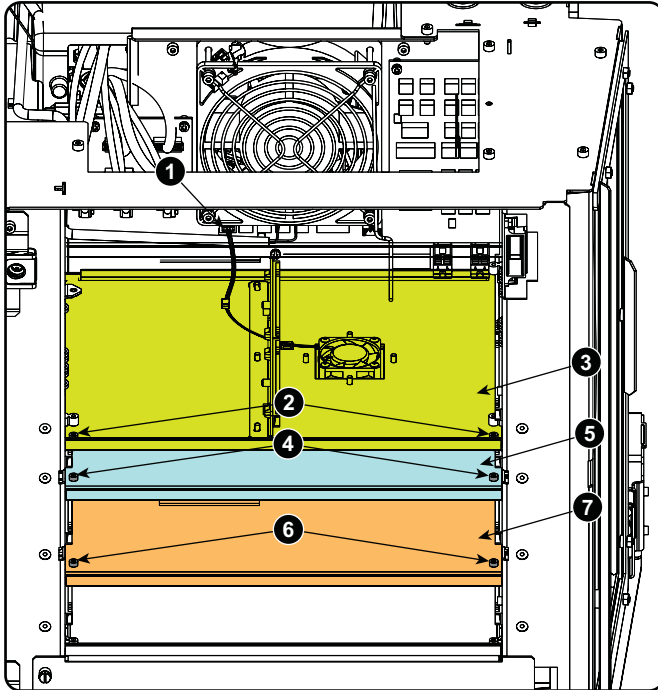

Image 13-37
Intermediary plate

2. To remove the next plate (5), turn out both fixation screws (4) and slide out the plate. Repeat in the same way for the next plate (7).
3. Unplug all cables from the signal backplane. Those inside the card cage and those next to the fans accessible via the front side.



Image 13-38
Backplane connections



4. From inside the card cage, remove the screws 1 to 6

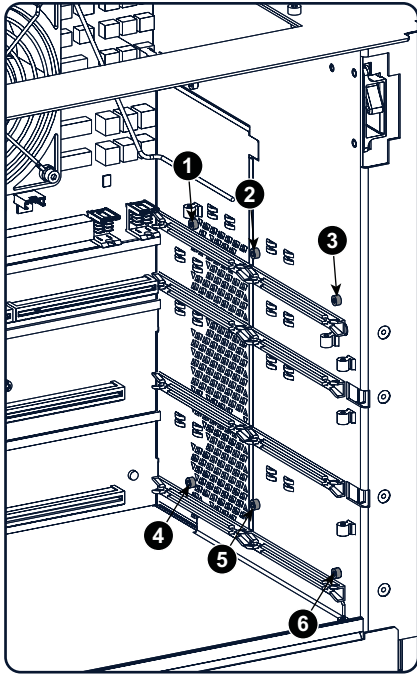

Image 13-39
Side card cage, screws

5. From the front side, pull the fan assembly a little bit forward and turn it to the left, or take it out completely. The blue and black wires coming from the SMPS are tied to the fan assembly. To make it possible to move the assembly forward, open the SMPS compartment and unplug the connector with the blue and black wires (reference 3 and 4 on image 13-41).

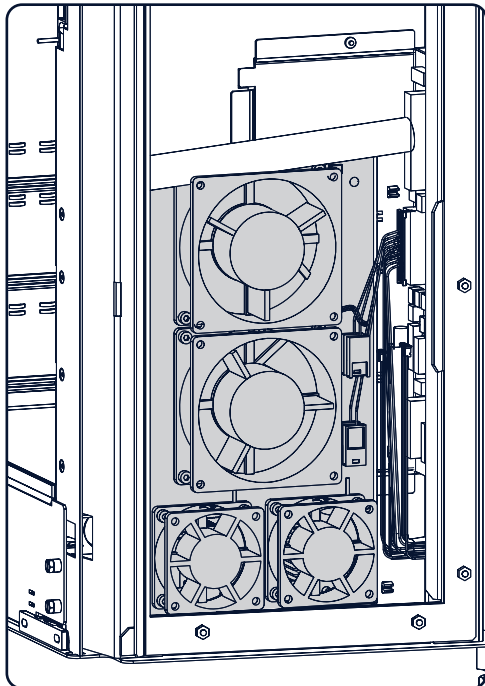
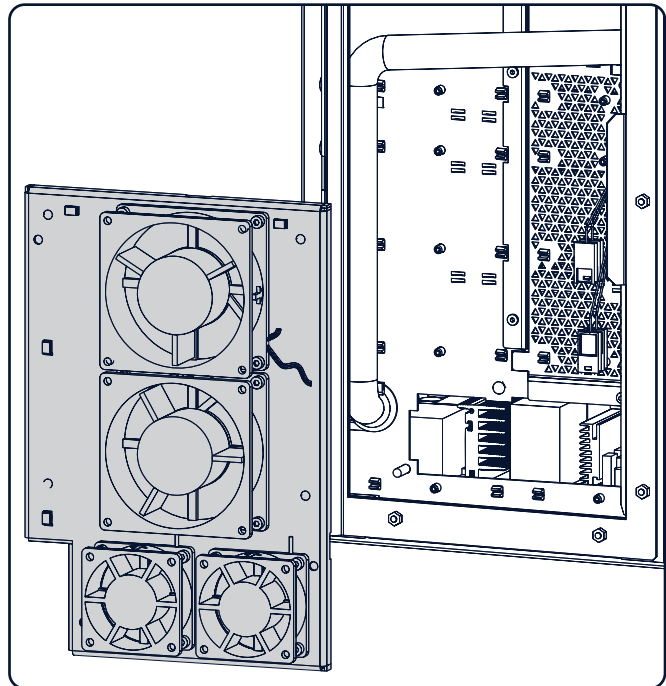

Image 13-40
Fan assembly removal



13. Card Cage

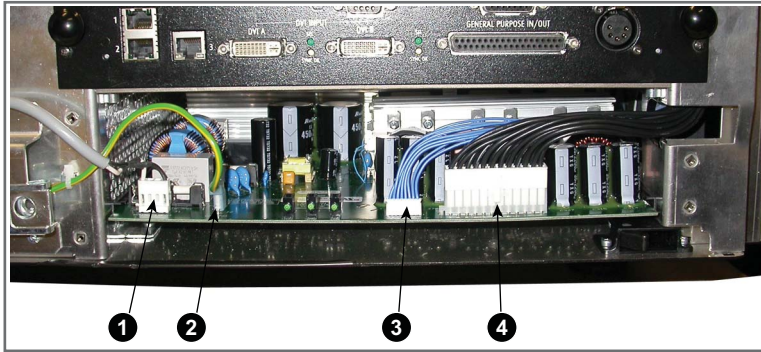

Image 13-41
SMPS connections

6. Pull out the hatch in the side of the card cage.

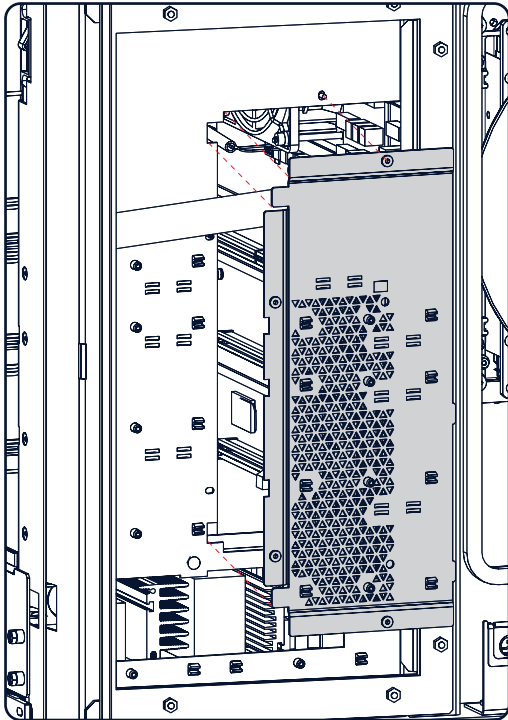

Image 13-42
Hatch removal

7. Remove the fixation screws 1 to 11 of the backplane unit.

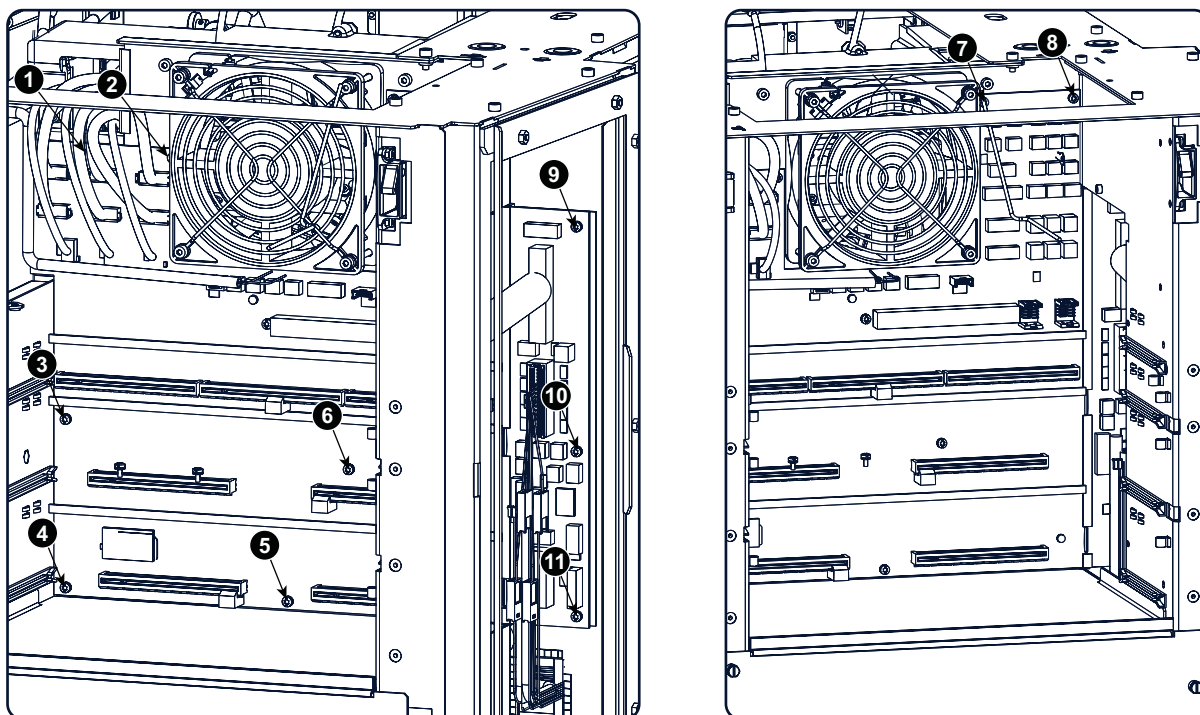

Image 13-43
Backplane fixation screws

8. Pull the signal backplane a little bit forward Pivot the left side as far as possible and slide out the board.

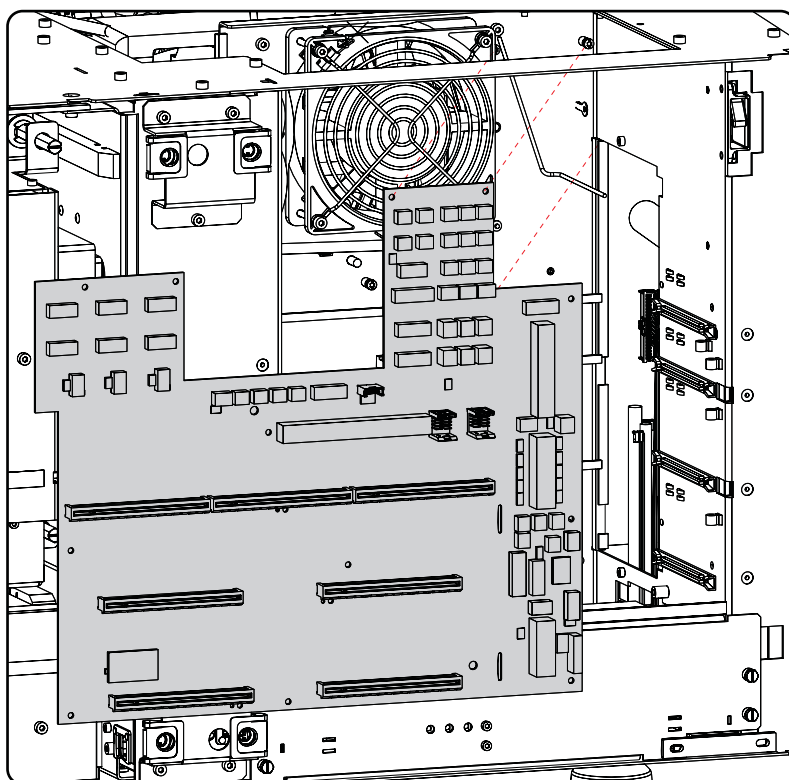

Image 13-44
Signal backplane removal

9. Remove the projector ID card.
Push the card holder a few millimeters to the left until the lock opens.
Turn it over and slide out the projector ID card.

13. Card Cage

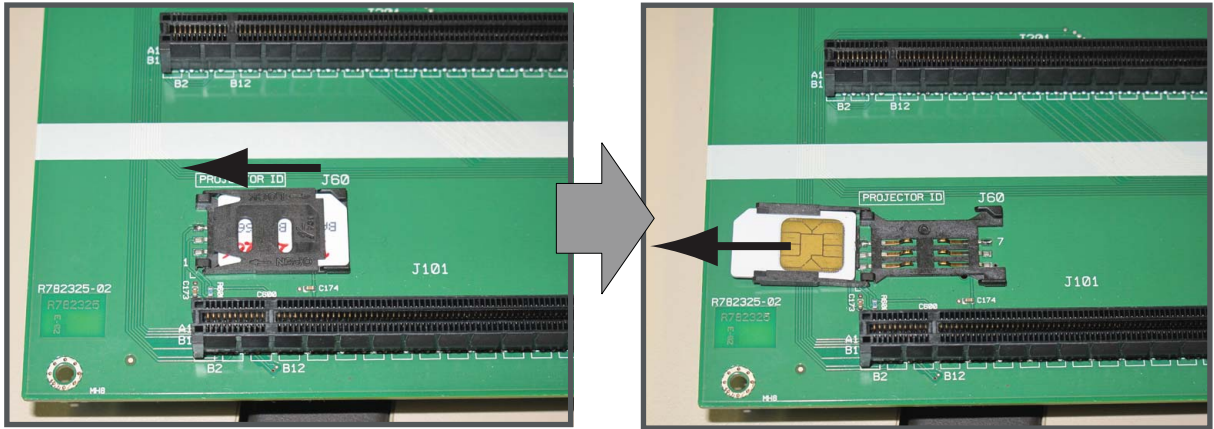

Image 13-45
Projector ID card removal

Mounting new signal backplane

1. Open the Projector Id card holder by pushing it a few millimeters to the left and turn it over. Insert the Projector ID card with the chip upwards. Turn the holder back, push it a little bit down while sliding it to the right until it locks.

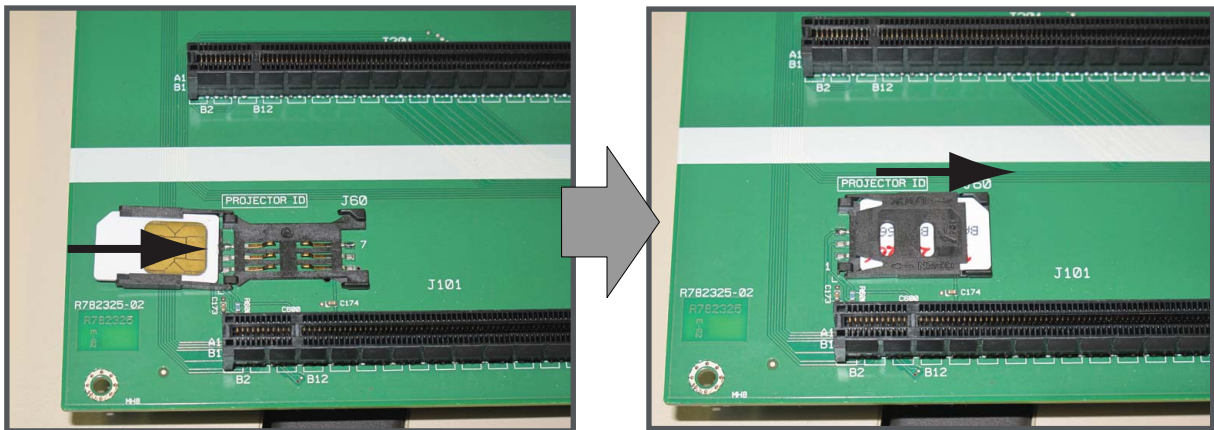

Image 13-46
Projector ID card, installation

2. Take the new backplane and slight the right side under an angle through the gap in the side of the card cage. Pivot the backplane on its place.

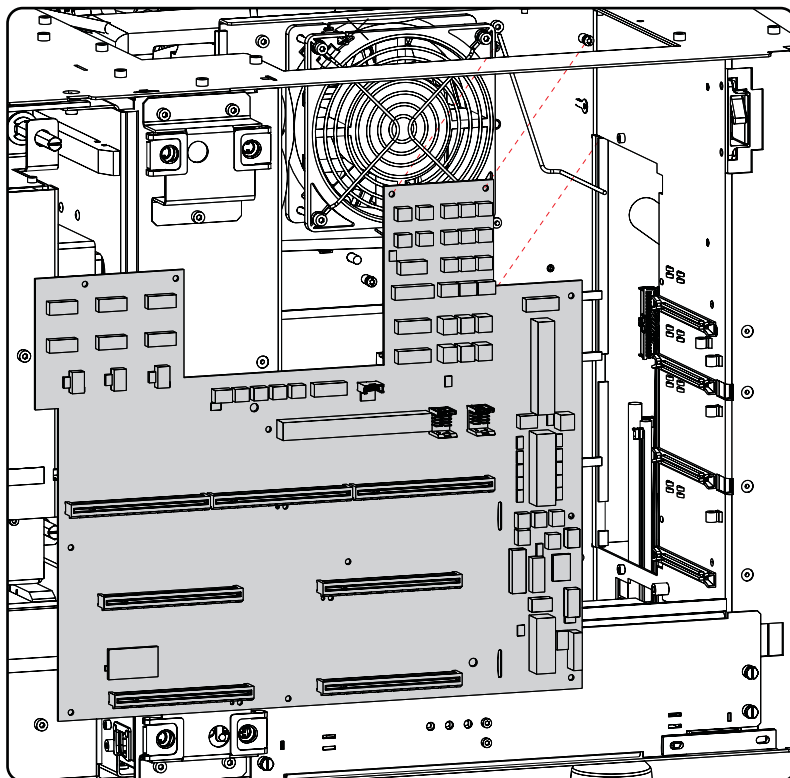

Image 13-47
Signal backplane insertion

3. Drive in screw 1 to 11.

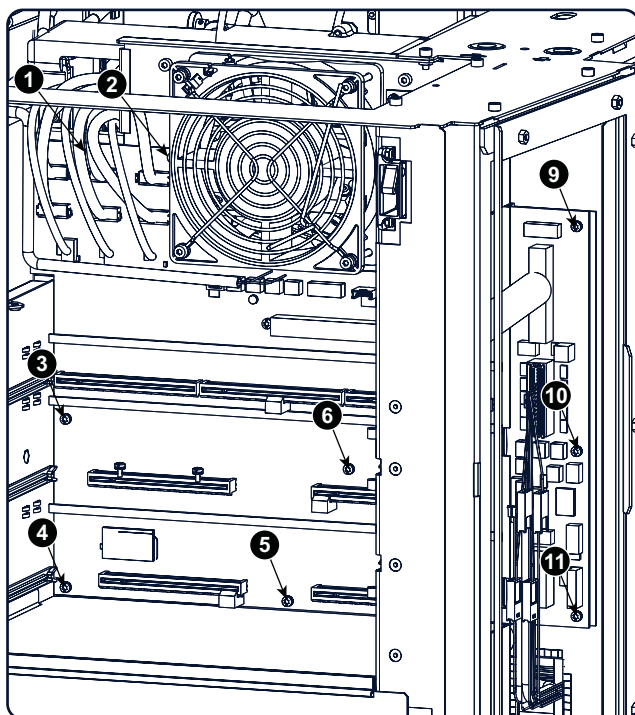
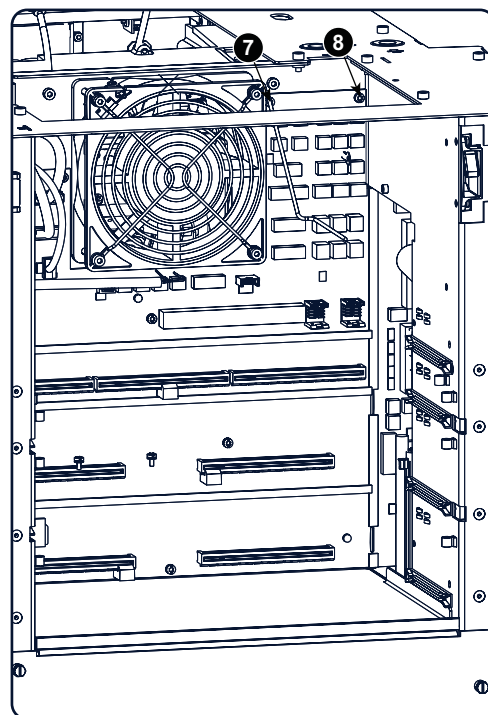

Image 13-48
Backplane fixation screws

4. Place the hatch back on its place.



13. Card Cage

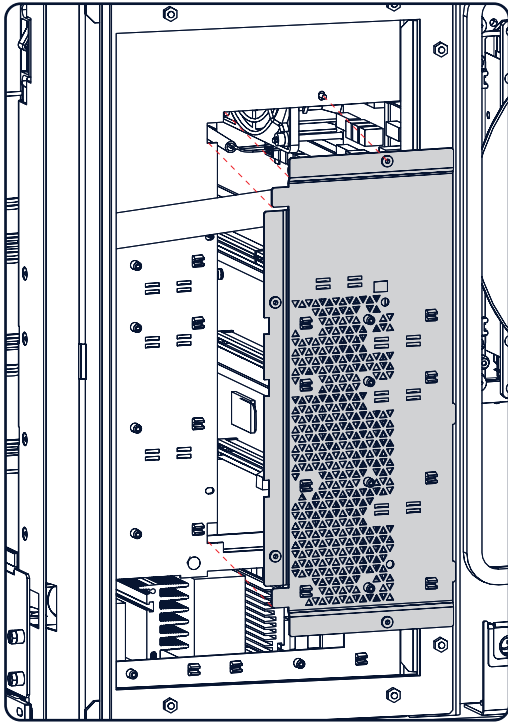

Image 13-49
Hatch installation

5. Mount the fan assembly back on its place.
Pull the blue and black wire unit towards the Switched mode power supply and plug-in both wire units (3 an d4).

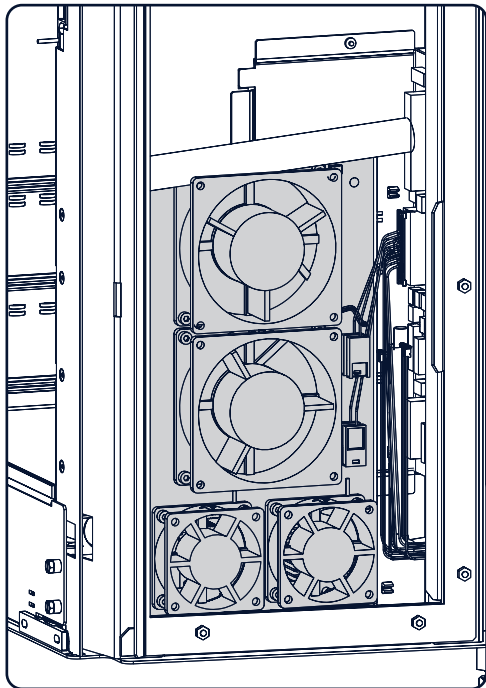
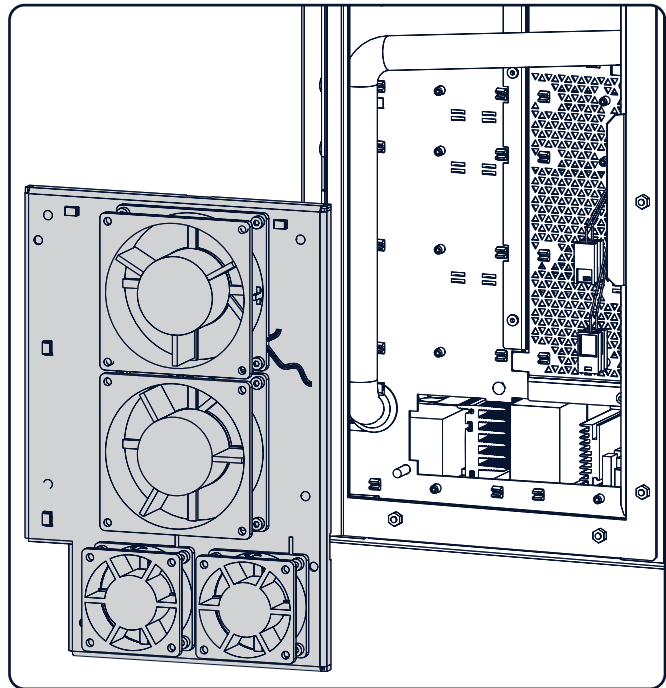

Image 13-50
Fan assembly installation



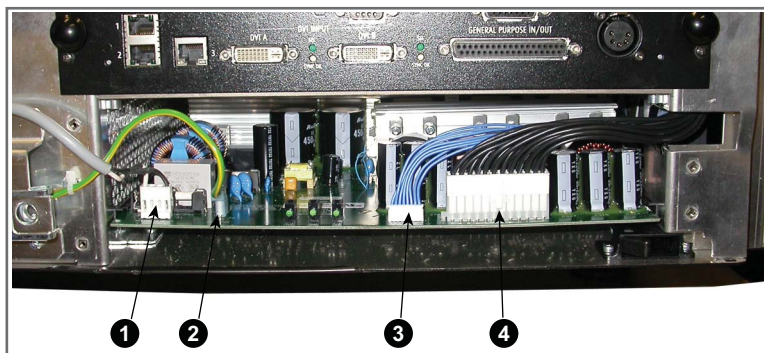

Image 13-51
SMPS connections

6. From the inside of the card cage, drive in screw 1 to 6 to fixate the fan assembly.

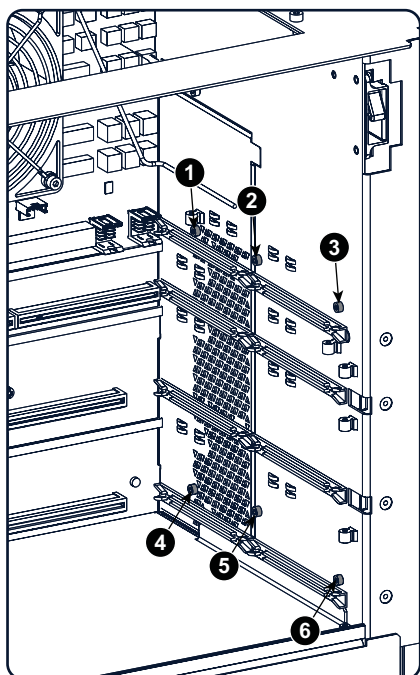

Image 13-52
Side card cage, screws

7. Make all electrical connections. See *“Electrical connections”* further in this topic for more info
8. Insert the lower intermediary plate and drive in both fixation screws.
Repeat for the second intermediary plate and the upper plate (plate with fan)

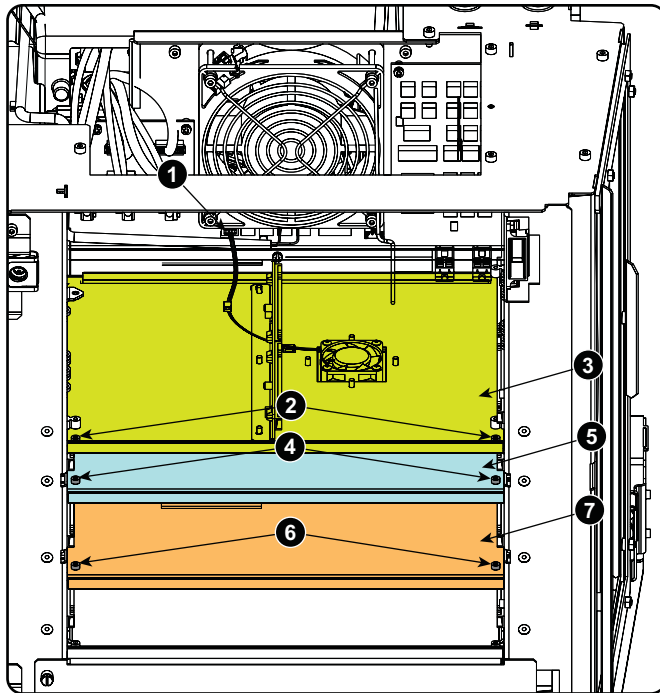

Image 13-53
Intermediary plates

9. Reconnect the fan with the signal backplane.

Finalizing the procedure

1. Reinstall the SMPS cover plate.
 Insert from top to bottom:
 - the fan controller board.
 - the Integrated cinema controller board
 - the HD-SDI board
 - the Cinema controller board
2. Mount the button panel, "Installation of the button unit", page 230.
3. Mount the convergence cover plate.
4. Reinstall the housing, see Removal and Installation of projector covers.

Electrical connections

Formatter connections

All formatter cables, data and power, have a colored cable tie. There are 3 cables per color available, two with same connector but one with one cable tie and one with 2 cable ties. The color name is screened on the printed circuit board (1, 2 and 3). Plug in the cable with e.g. a red cable tie into the connector with the same size and with the indication red. For those with the same connector plug the one with one cable tie into the upper connector (row A), The one with 2 cable ties into the second connector (row B). Repeat for all other cables.

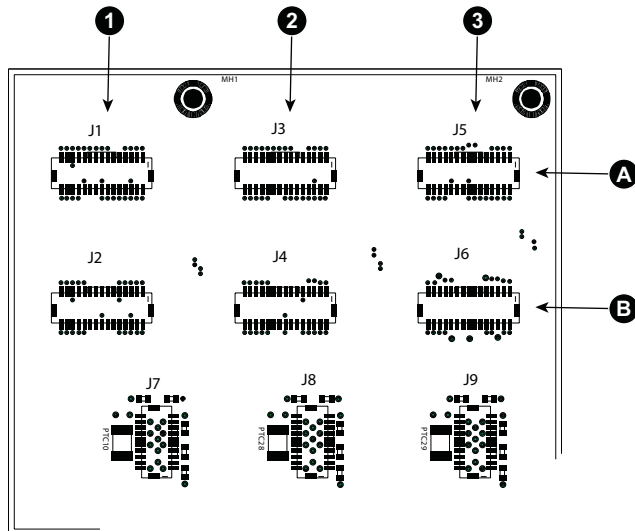

Image 13-54
Formatter connections

- 1 Red formatter connections
- 2 Green formatter connections
- 3 Blue formatter connections
- A Cables with one cable tie
- B Cables with two cable ties

Right side connections

Color convention for the connections.

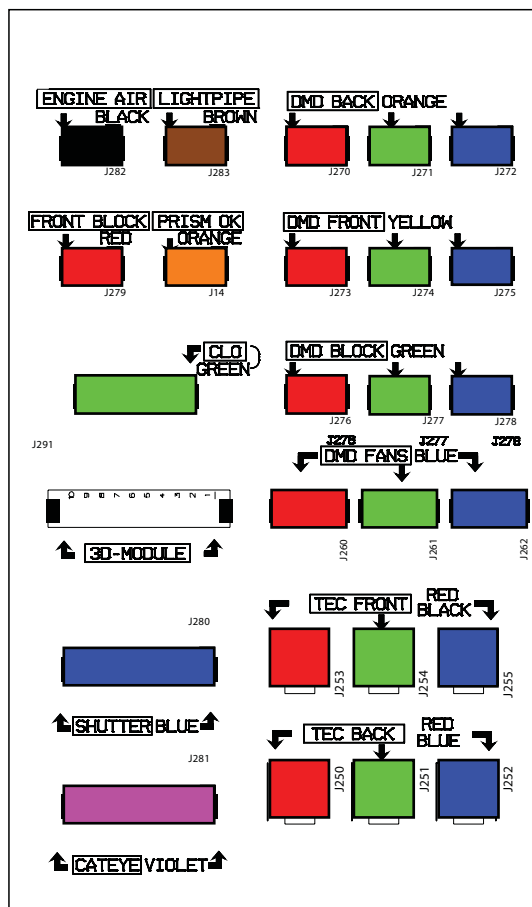

Image 13-55
Color coding cables

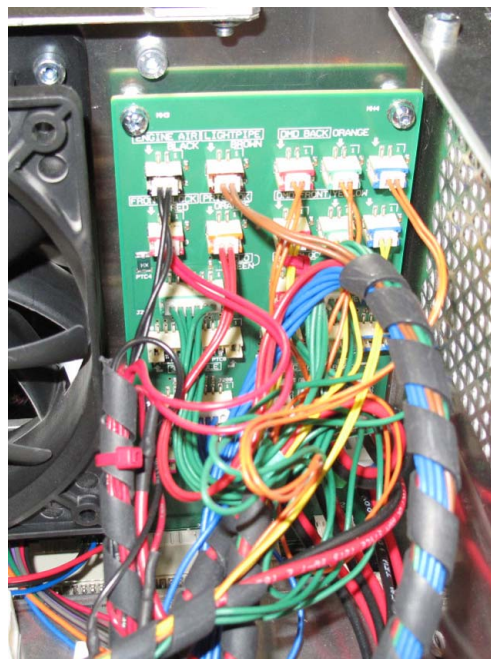

Image 13-56
Color coding cables, image

The color indication on the socket corresponds with the colored cable tie on the cable next to the connector.
The screened color indication just above the sockets corresponds with the color of the wires in the cable tree.

Connections below light processor compartment fan

13. Card Cage

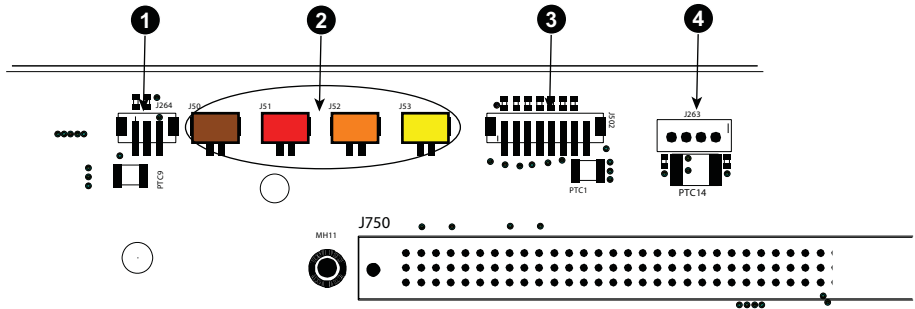
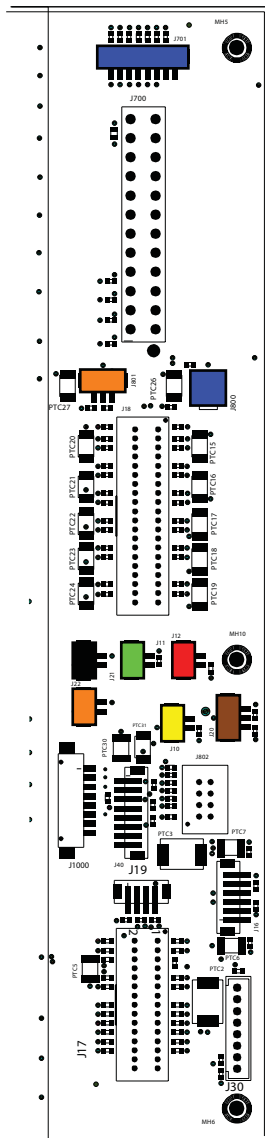

Image 13-57
Cabling below fan

- 1 ICP fan connection
- 2 Security door switches
- 3 Button module connection
- 4 Light processor compartment fan connection

The color indication on the socket corresponds with the color of the wires in the cable tree.

Connections accessible via front side



13.15 Replacement of the Link Decryptor

Location

The link decryptor is mounted on the HD-SDI board.

Necessary tools

Torx screwdriver T10

How to replace

1. Remove the HD-SDI board in the card cage. See "Removing a board in the card cage", page 221.
2. Turn out the 4 fixation screws.

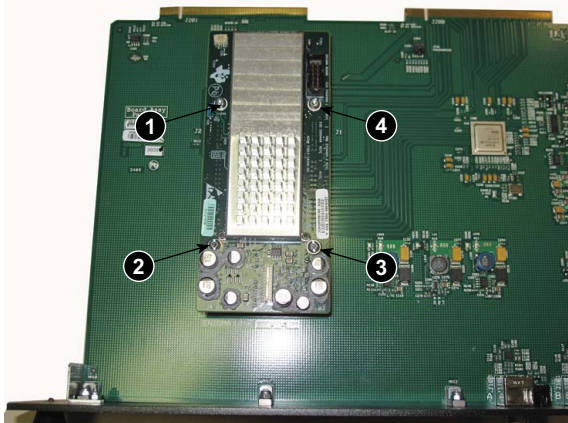

Image 13-60
Link decryptor fixation

3. Pull off the current mounted link decryptor board.
4. Unpack the new link decryptor board and plug it in both connectors at the same time (black and white connector on the link decryptor must facing the board connectors of the HD-SDI board..

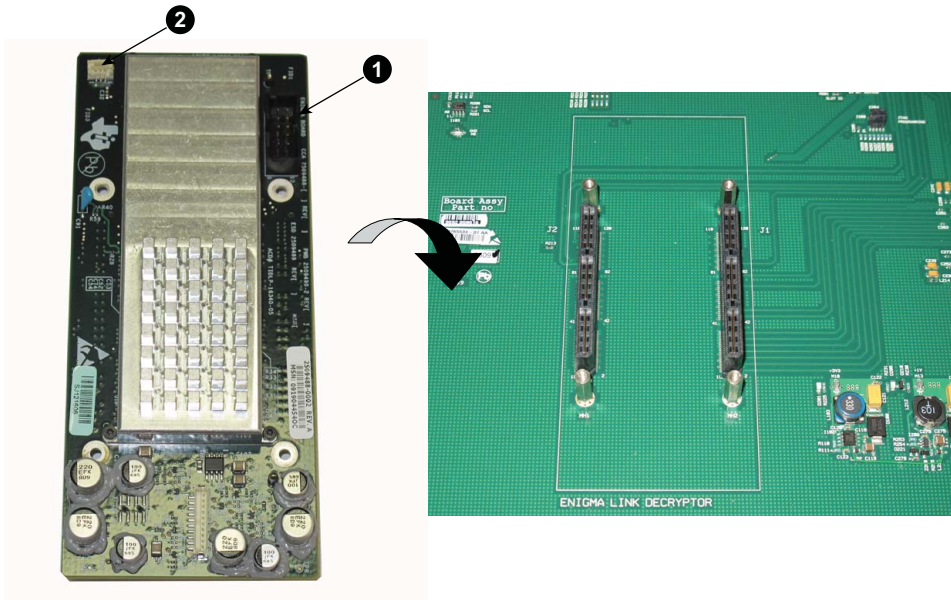

Image 13-61
Link decryptor, mounting

5. Drive in the 4 fixation screws.
6. Re-install the board in the card cage.



When inserting a new Link decryptor, the link decryptor software must be re-installed. See "Software update via Communicator (DC update companion)", page 255.



A marriage between the new link decryptor and the ICP board must be realized; Follow the procedure to clear a security warning on the projector. See "Authorization to clear security warning on the projector", page 253.

13.16 Authorization to clear security warning on the projector

When is an authorization required to clear the security warning?

If a module has been removed or if the sealed compartment has been opened, an authorization will be required to clear the security warning.

Necessary tools

- Security key (Dallas iButton®).
- Authorization pin code.

Authorization procedure to clear security warning

1. Ensure that all modules are properly installed.
2. Start up the projector (standby mode).
3. Initiate authorization by holding the security key in the security socket D..

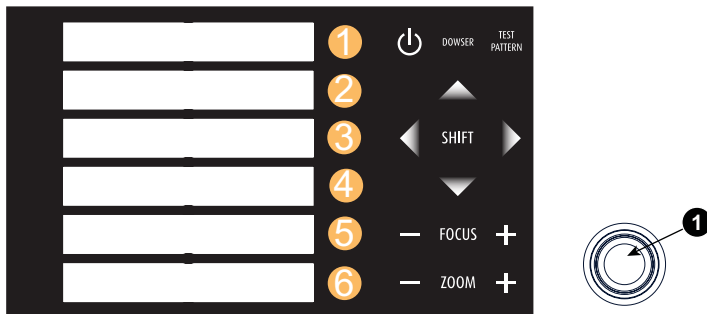

Image 13-62
Keypad

The color of the backlight of the numeric keys 1 to 6 of the local keypad changes from blue to yellow.

4. Enter pin code within 5 seconds.
 - In case no keys are pressed, the color of the backlight of the numeric keys 1 to 6 changes back to blue.
 - In case of an **incorrect code** entry, the color of the backlight of the numeric keys changes to **red** for 1 second and then back to blue.
 - In case of a **correct code** entry, the color of the backlight of the numeric keys 1 to 10 changes to **green** for 1 second and then back to blue.



Each attempt to clear the security warning and its result (successfully or unsuccessfully) is logged inside the projector.

13.17 Replacement of the Status Light



To access the Status Light board the rear cover of the projector has to be removed. This procedure assumes that the rear cover is already removed.

Necessary tools

2,5 mm Allen wrench.

How to replace the Status Light from the projector?

1. Remove the two indicated screws (reference 1) of the Status Light board. As a result the board will come loose but remains connected via the wire unit.
2. Disconnect the wire unit (reference 2) of the Status Light board.

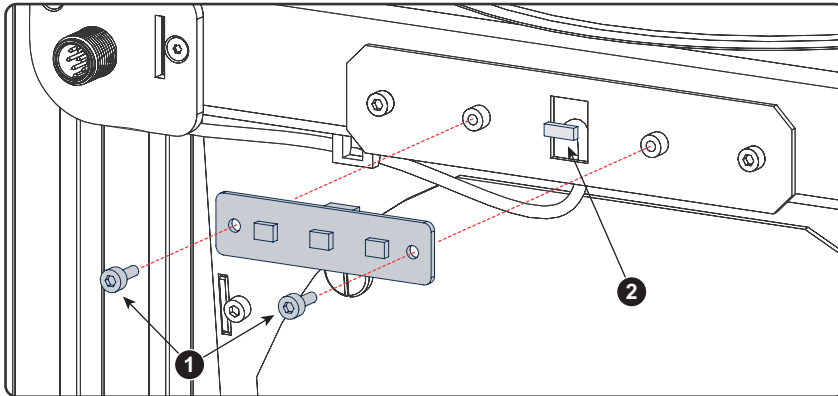

Image 13-63

3. Connect a new Status Light board with the wire unit.
4. Fasten the new Status Light board with two screws. Use a 2,5 mm Allen wrench.

14. SOFTWARE UPDATE VIA COMMUNICATOR (DC UPDATE COMPANION)

Overview

- Software upgrade, launch DC update companion
- Software upgrade, projector, ICMP or touch panel
- ICP software upgrade
- Link decryptor software update
- Update logging



During an upgrade, certificate (code 5815) and key errors (code 5816) are possible. Restarting the projector will resolve these errors. If these errors remain after a restart, replace the ICP board.

14.1 Software upgrade, launch DC update companion

What can now be done ?

The following updates of the software are possible with Communicator (DC update companion)

- Barco DC package update:
 - Projector software
 - Touch panel software
- Enigma link decryptor software
- Integrated Cinema Processor (ICP) software
- ICMP software

Download the corresponding update package from Barco's web site, <http://www.barco.com> on your PC. Select via the product name.

For Enigma link decryptor and ICP update package, unzip the package file into a new directory.

For the projector software, ICMP and the touch panel software package, unzipping is not possible. the file can be used as is.

The ICP and Linkdecryptor package file contains at least

- a zipped version of the update program which contains a *setup.exe* file to install the program. Can also be unzipped.
- a release file with the new software.
- a release note (pdf document)
- a Software Manifest for ICP Production Release (pdf document)

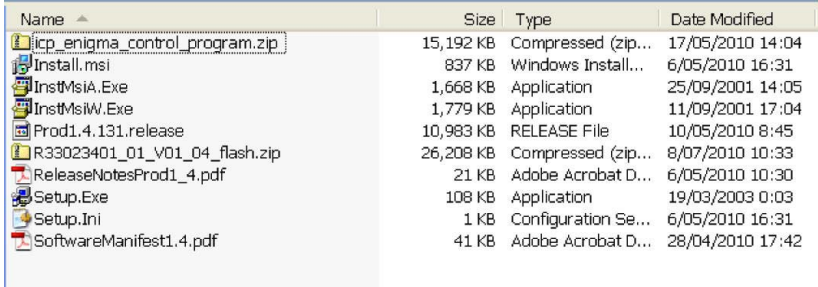

| Name | Size | Type | Date Modified |
|--------------------------------|-----------|---------------------|------------------|
| icp_enigma_control_program.zip | 15,192 KB | Compressed (zip...) | 17/05/2010 14:04 |
| Install.msi | 837 KB | Windows Install... | 6/05/2010 16:31 |
| InstMsiA.Exe | 1,668 KB | Application | 25/09/2001 14:05 |
| InstMsiW.Exe | 1,779 KB | Application | 11/09/2001 17:04 |
| Prod1.4.131.release | 10,983 KB | RELEASE File | 10/05/2010 8:45 |
| R33023401_01_V01_04_flash.zip | 26,208 KB | Compressed (zip...) | 8/07/2010 10:33 |
| ReleaseNotesProd1_4.pdf | 21 KB | Adobe Acrobat D... | 6/05/2010 10:30 |
| Setup.Exe | 108 KB | Application | 19/03/2003 0:03 |
| Setup.Ini | 1 KB | Configuration Se... | 6/05/2010 16:31 |
| SoftwareManifest1.4.pdf | 41 KB | Adobe Acrobat D... | 28/04/2010 17:42 |

Image 14-1
Content ICP update package



DC Update Companion can also be started as a separate application. The start up button is located next to the Communicator start button in the start programs tree.

How to launch

1. While in the *Maintenance* tab page, click on **Software update** (1).

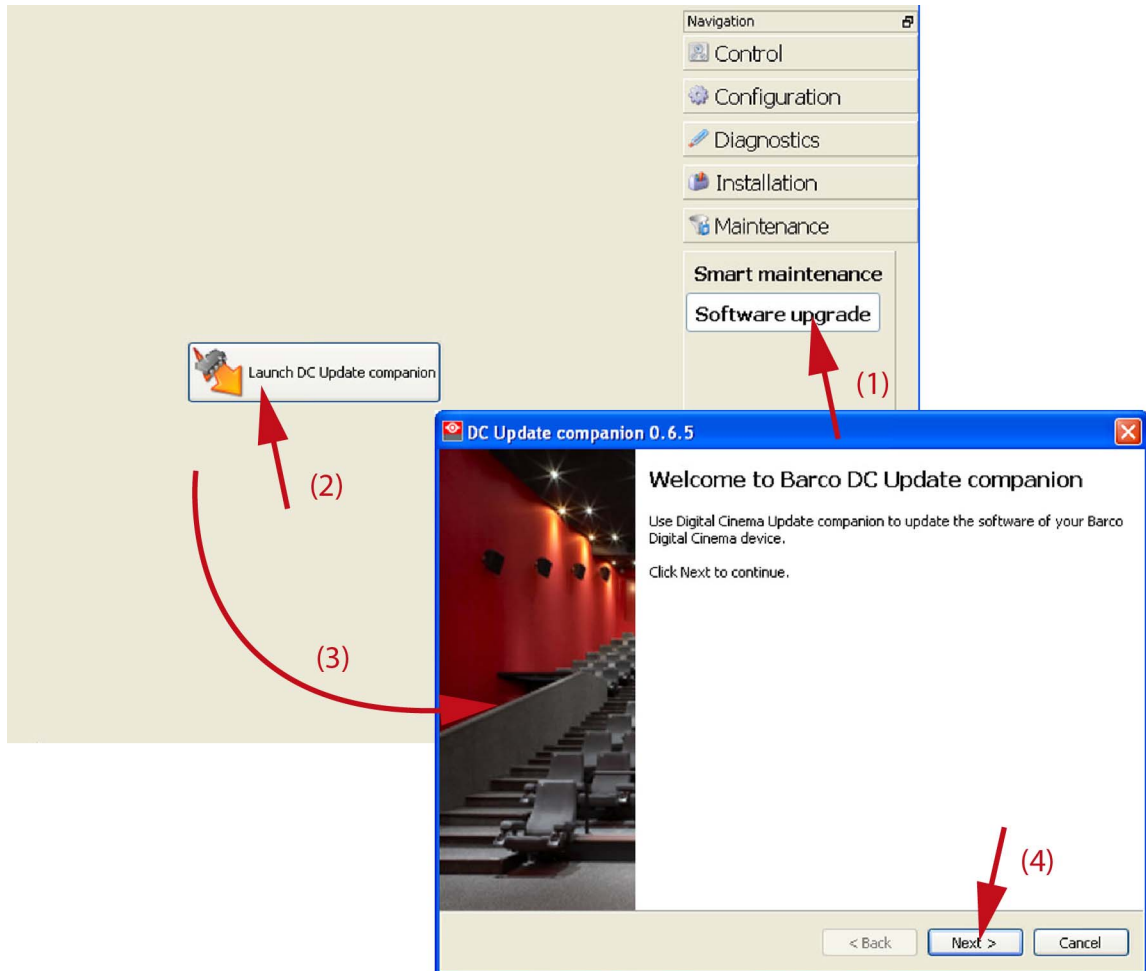

Image 14-2
Launch DC update companion

2. Click on **Launch DC update companion** (2).
The *DC update companion* window starts up (3).
3. Click **Next** to continue (4).
4. Read the licence agreement and check accept. Click **Next** to continue.

14. Software update via Communicator (DC update companion)

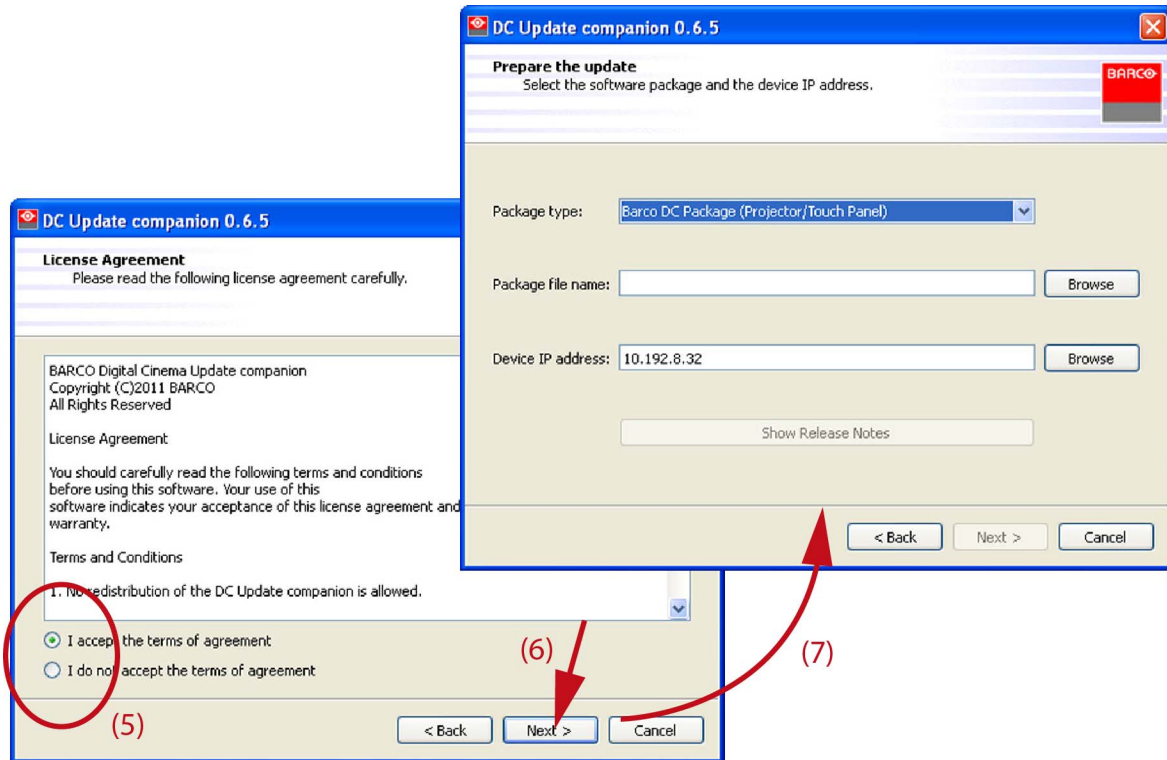

Image 14-3
Start up selection window

5. Continue with the specific procedure for each type of package.

14.2 Software upgrade, projector, ICMP or touch panel

How to update

1. Launch the *DC Update Companion* as described in "Software upgrade, launch DC update companion", page 256.
2. Select package type. Click on the drop down box (1) and select Barco DC Package (for projector or touch panel update) or ICMP package (for ICMP update).

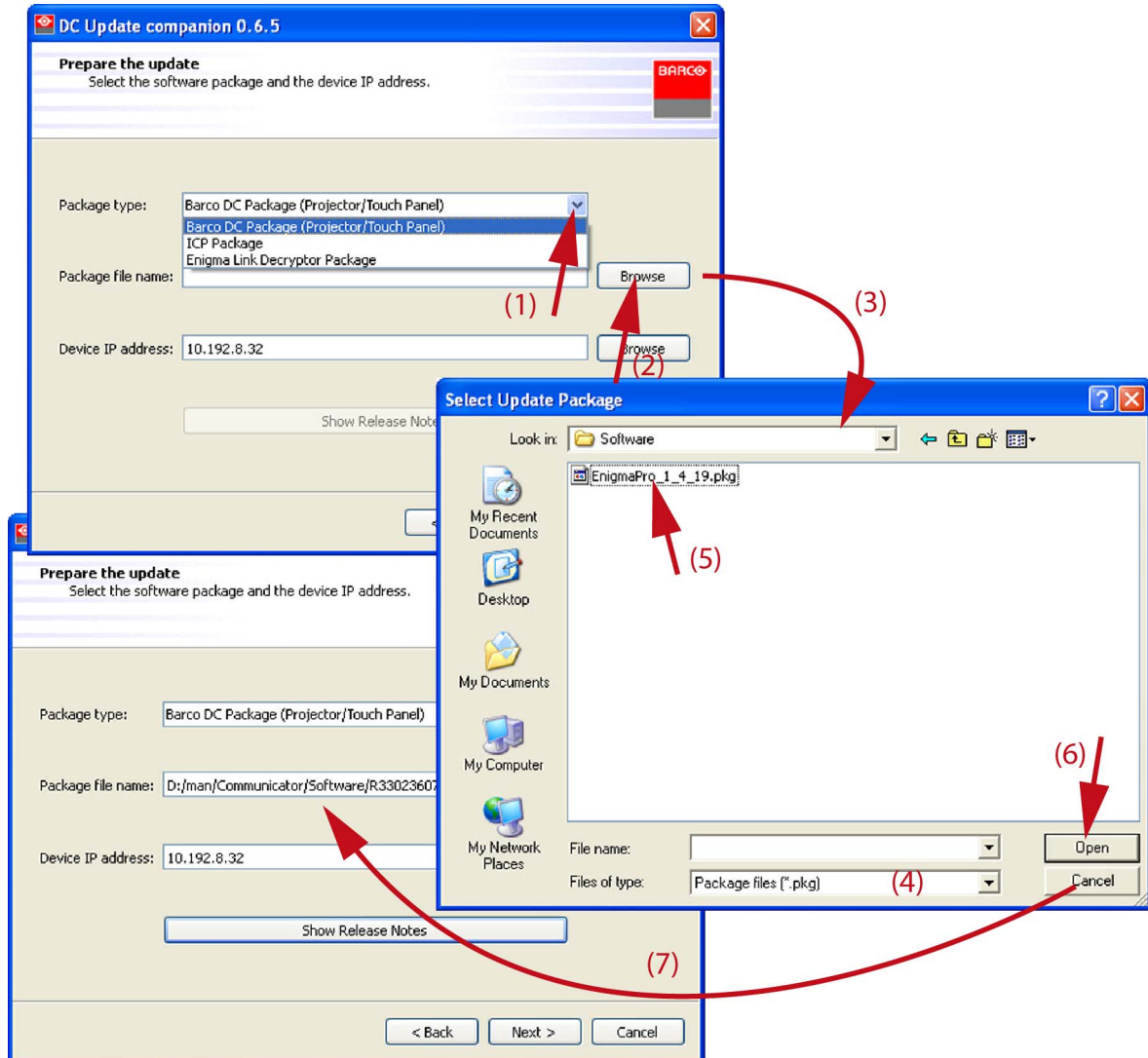

Image 14-4
Package file selection

3. Browse the package file name. Click on **Browse** (2) to open the Browser window (3).
The correct file type is already filled out (4).
4. Browse for the desired file (5), select the file and click on **Open** (6).
The Package file name line is filled out (7).
5. To read the release notes, click on **Show Release Notes** (8).

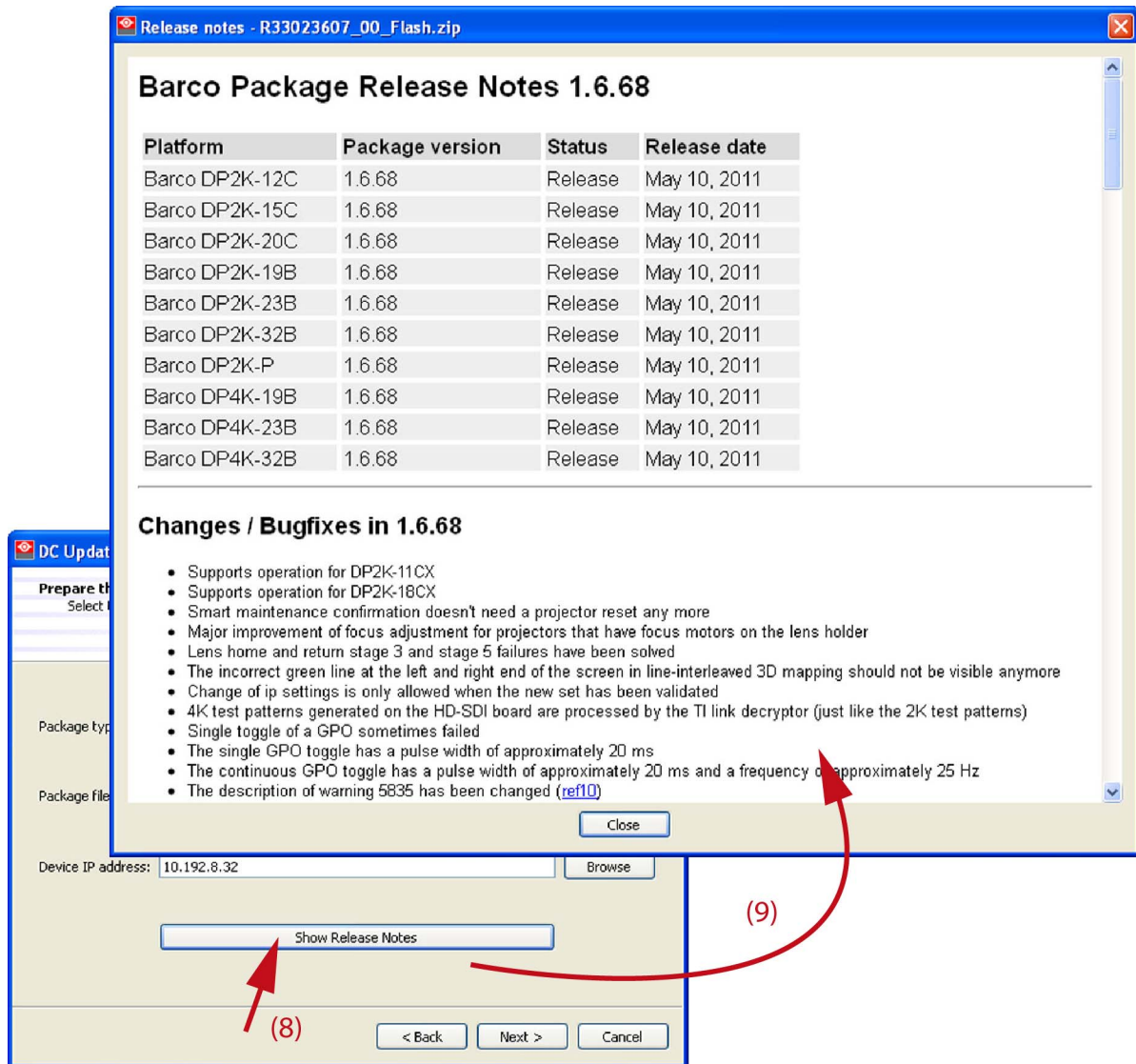

Image 14-5
Barco release notes

6. Enter the device IP address (10) or click on **Browse** to open a device selection window (11).

Note: The IP of the connected projector is already filled out. When using the DC Update Companion as stand alone program, then this field is blank.

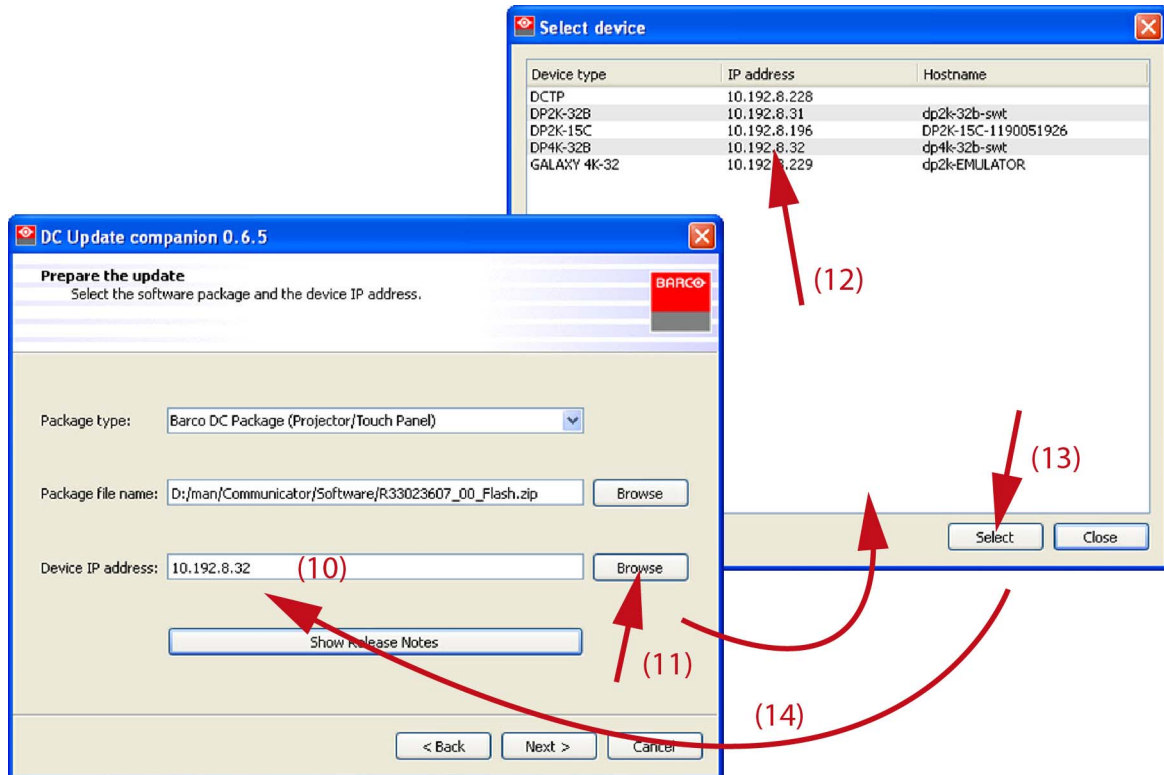

Image 14-6
IP selection

7. Select the desired IP address (12) and click **Select** (13).
The selected IP address is filled out next to *Device IP address*.
8. Click **Next** to continue.

14. Software update via Communicator (DC update companion)

The necessary information is gathered.

The current installed version is shown next to the package version (15).

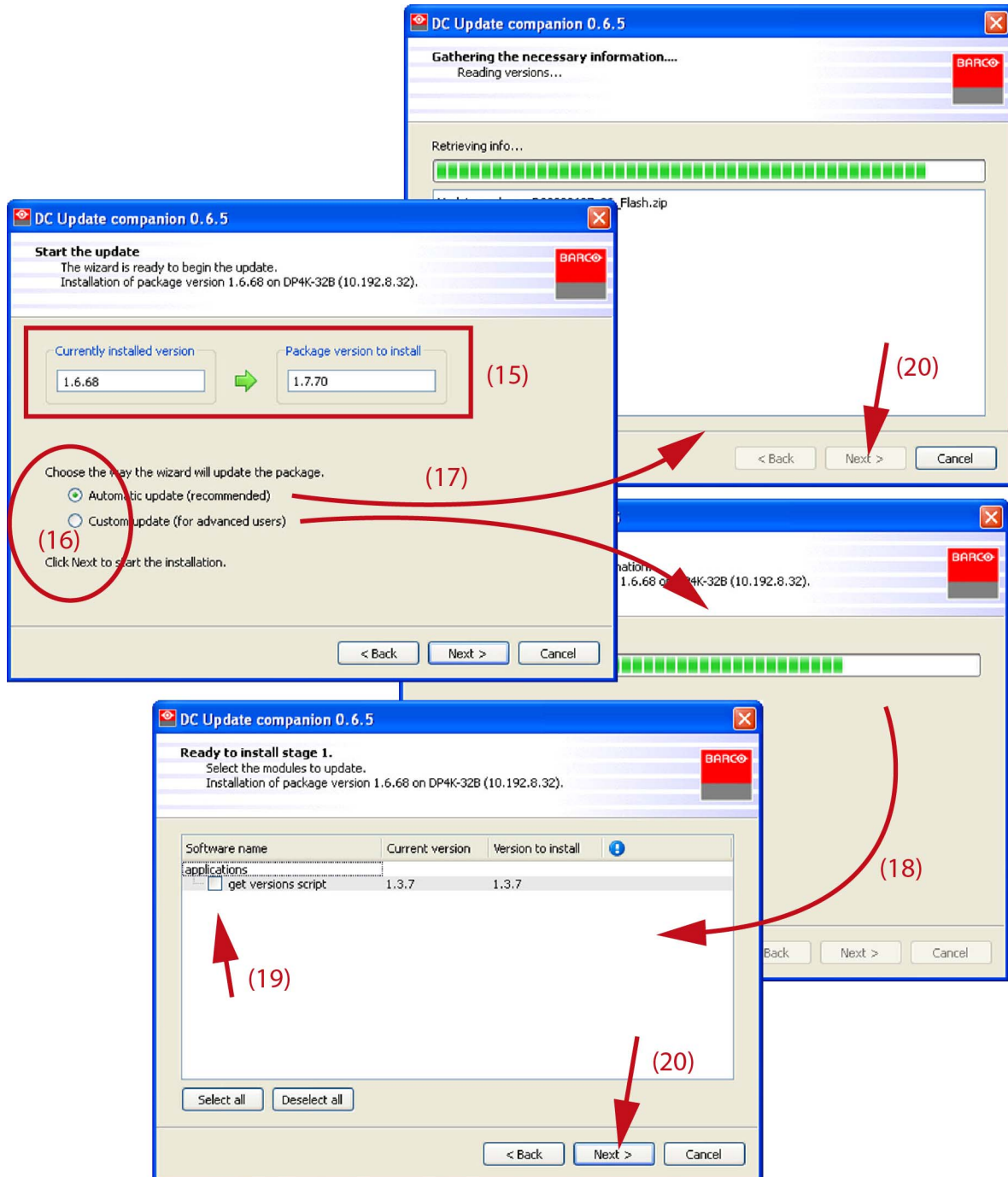

Image 14-7
Projector software update

9. Select the way the wizard will update the package. Check the desired radio button (16).
10. If automatically is selected the wizard gathered the information (17). Then click **Next** to start the update (20).
If custom update (for advanced users) is selected, the wizard starts collecting the information (17) of the different software modules.
11. Select the modules to update (19) and click **Next** to start the update (20).



The update can take a lot of time. Make sure not to interrupt the power during the update process. At the end, an update status will be displayed.

14.3 ICP software upgrade

About updating ICP board

The ICP board contains 2 slots to store software before this software can be installed. Therefore it is recommended to store the previous version of the software in a location and the current version in the other. When an new update becomes available, overwrite always the oldest version.

These 2 loaded versions make it possible to switch on an easy way between the current version and the previous one.

How to upgrade

1. Launch the *DC Update Companion* as described in "Software upgrade, launch DC update companion", page 256.
2. Select package type. Click on the drop down box (1) and select *ICP Package*.

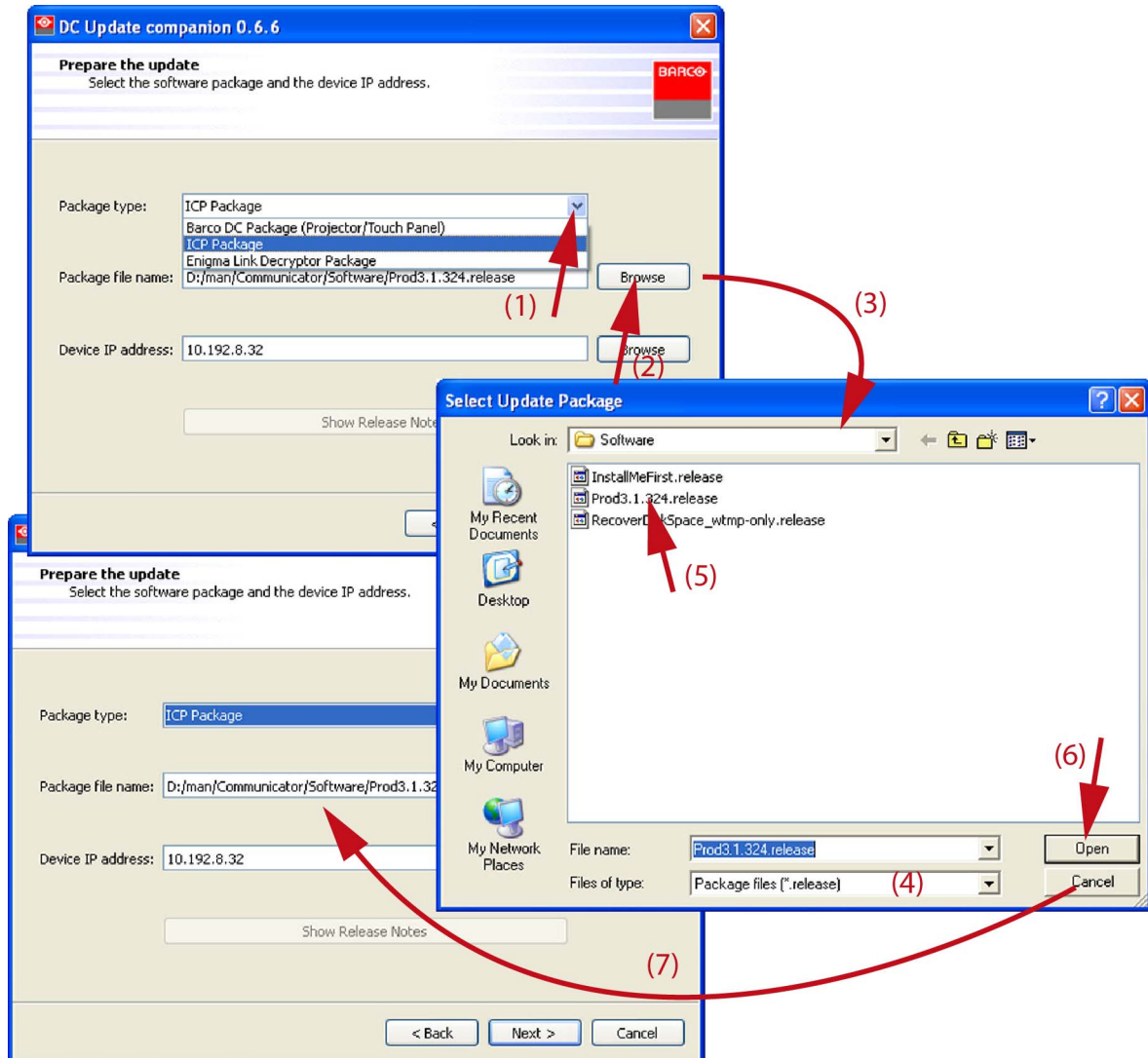

Image 14-8

3. Browse the package file name. Click on **Browse** (2) to open the Browser window (3).
Note: File has extension *release*.
The correct file type is already filled out (4).
4. Browse for the desired file (5), select the file and click on **Open** (6).
The Package file name line is filled out (7).
5. Enter the device IP address (10) or click on **Browse** to open a device selection window (11).
Note: The IP of the connected projector is already filled out. When using the DC Update Companion as stand alone program, then this field is blank.

14. Software update via Communicator (DC update companion)

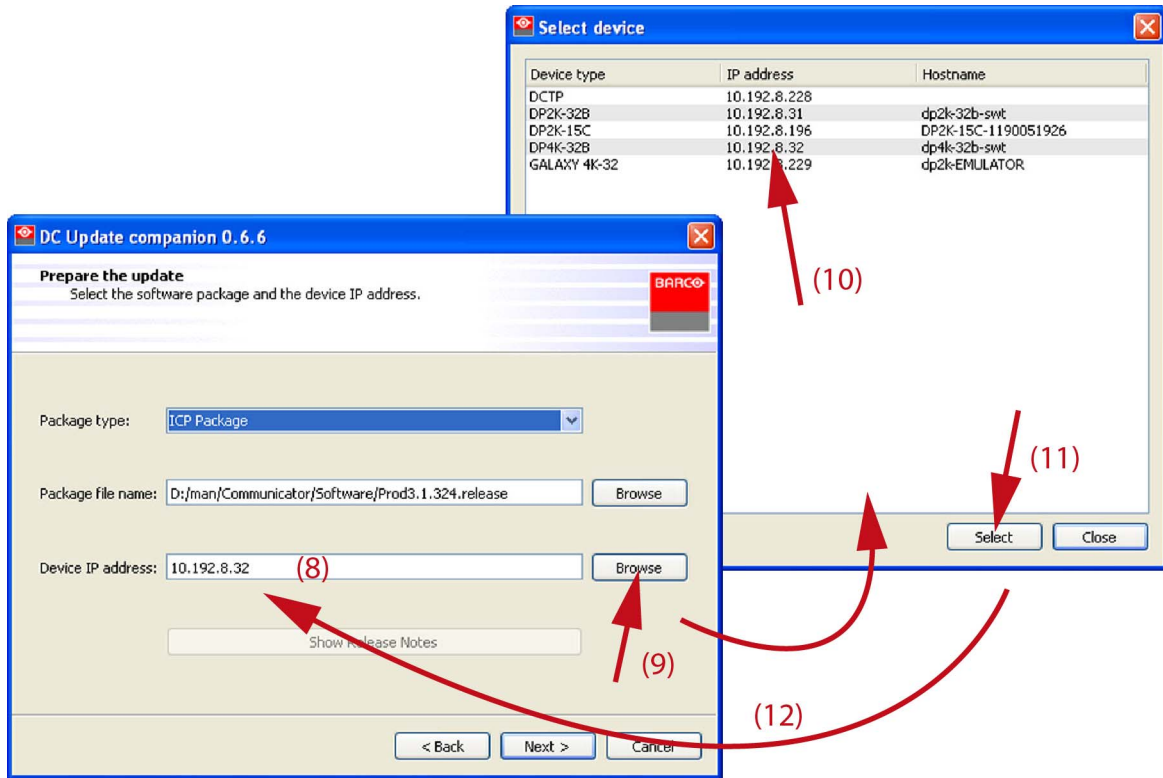

Image 14-9
IP selection

6. Click **Next** to continue.

The necessary information is gathered.

The current installed version is shown next to the package version (13).

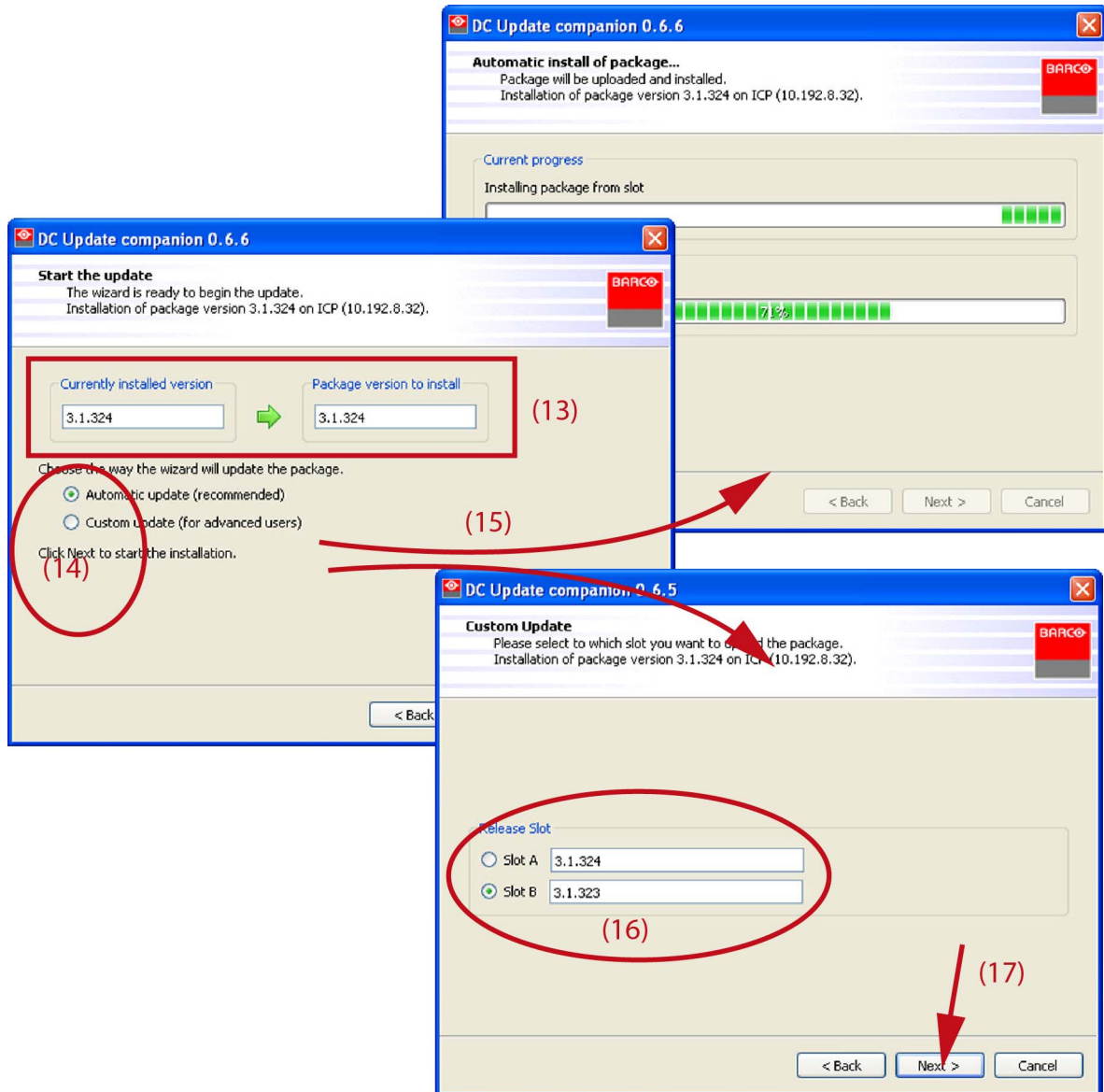

Image 14-10
Load and install software

7. Select the way the wizard will update the package. Check the desired radio button (14).
8. If automatically is selected the wizard will load the software in the oldest slot and install the software immediately (15). If custom update (for advanced users) is selected, the wizard displays the selection for slot A or slot B (16). Check the radio button of your choice and press **Next** (17).

The software will be loaded to the selected slot and will be installed immediately

When the update is finished, an status window is displayed.

14.4 Link decryptor software update

How to update

1. Launch the *DC Update Companion* as described in "Software upgrade, launch DC update companion", page 256.
2. Select package type. Click on the drop down box (1) and select *Enigma Link Decryptor Package*.

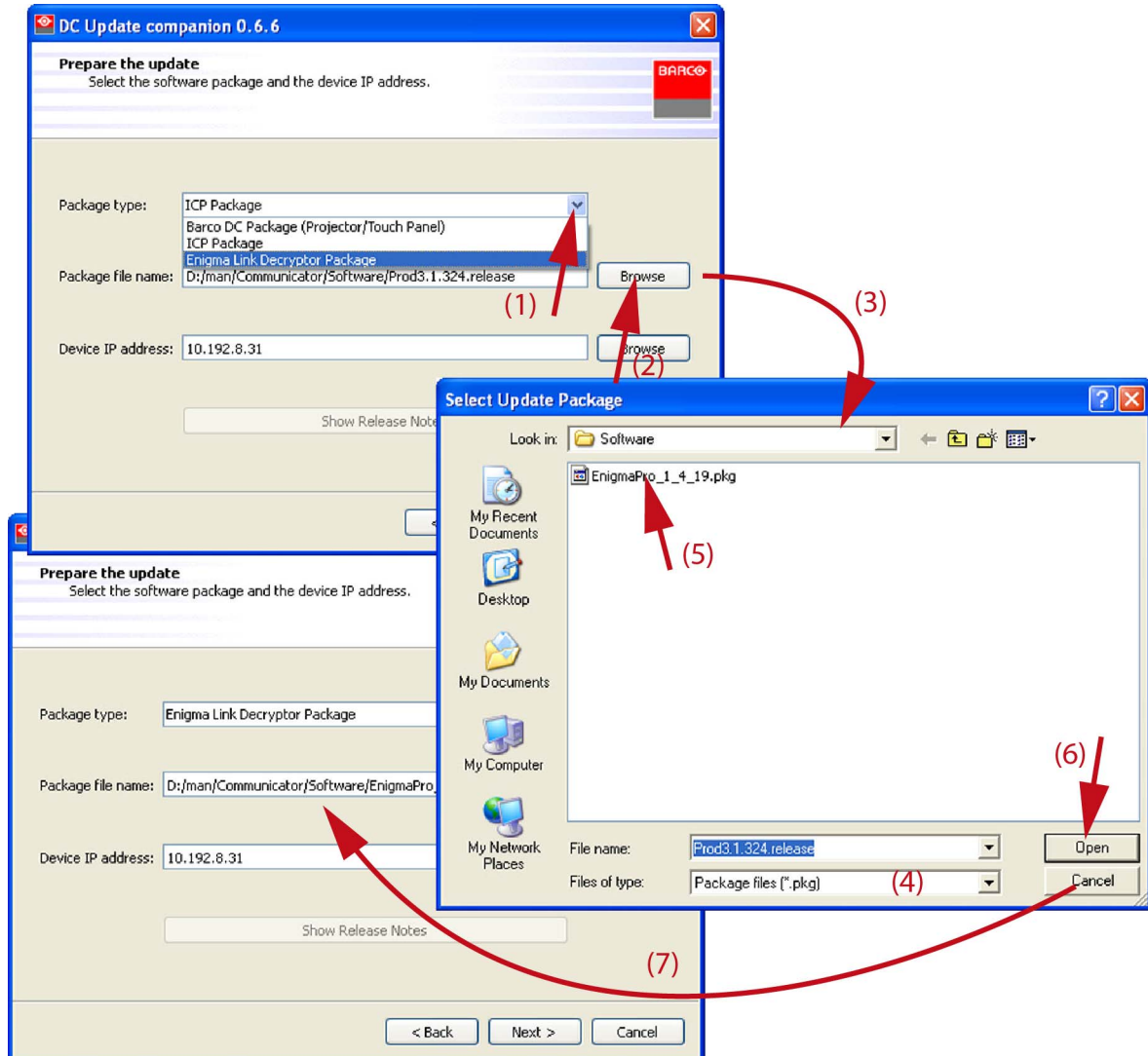

Image 14-11

3. Browse the package file name. Click on **Browse** (2) to open the Browser window (3).
The correct file type is already filled out (4).
4. Browse for the desired file (5), select the file and click on **Open** (6).
Note: File has extension *pkg*.
The Package file name line is filled out (7).
5. Enter the device IP address (10) or click on **Browse** to open a device selection window (11).
Note: The IP of the connected projector is already filled out. When using the DC Update Companion as stand alone program, then this field is blank.

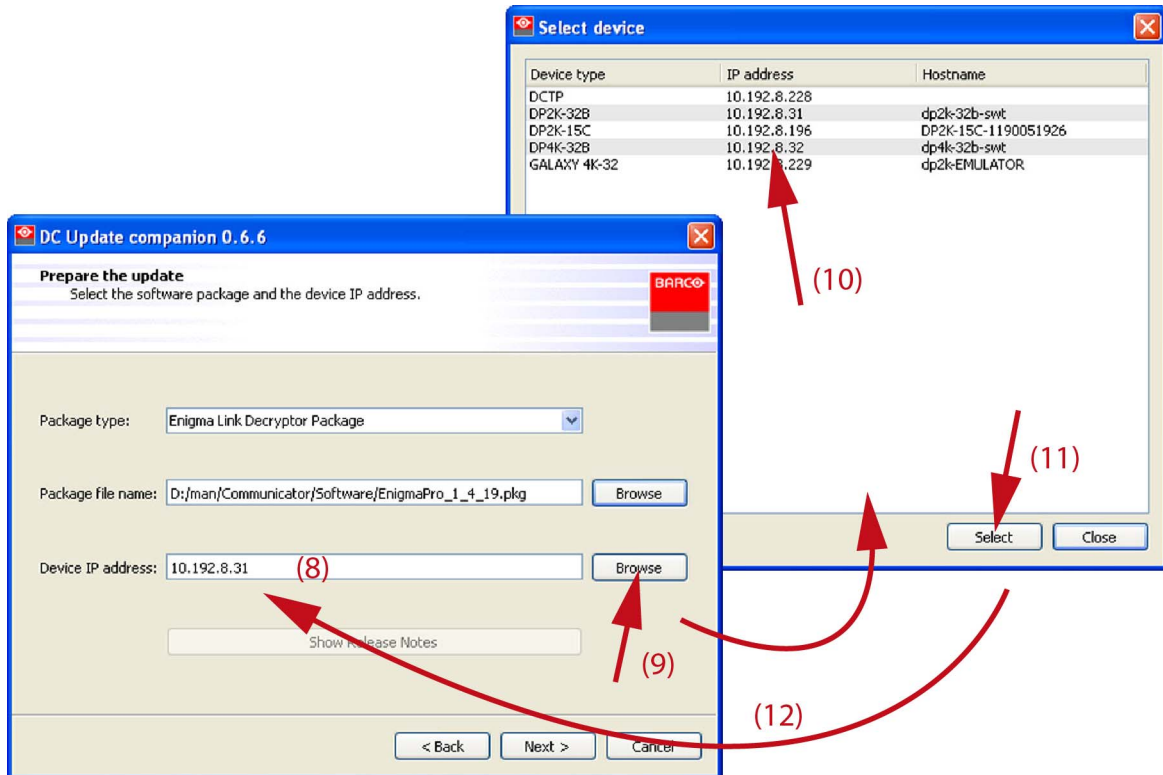

Image 14-12
IP selection

- Click **Next** to continue.
The necessary information is gathered.
The current installed version is shown next to the package version (13).

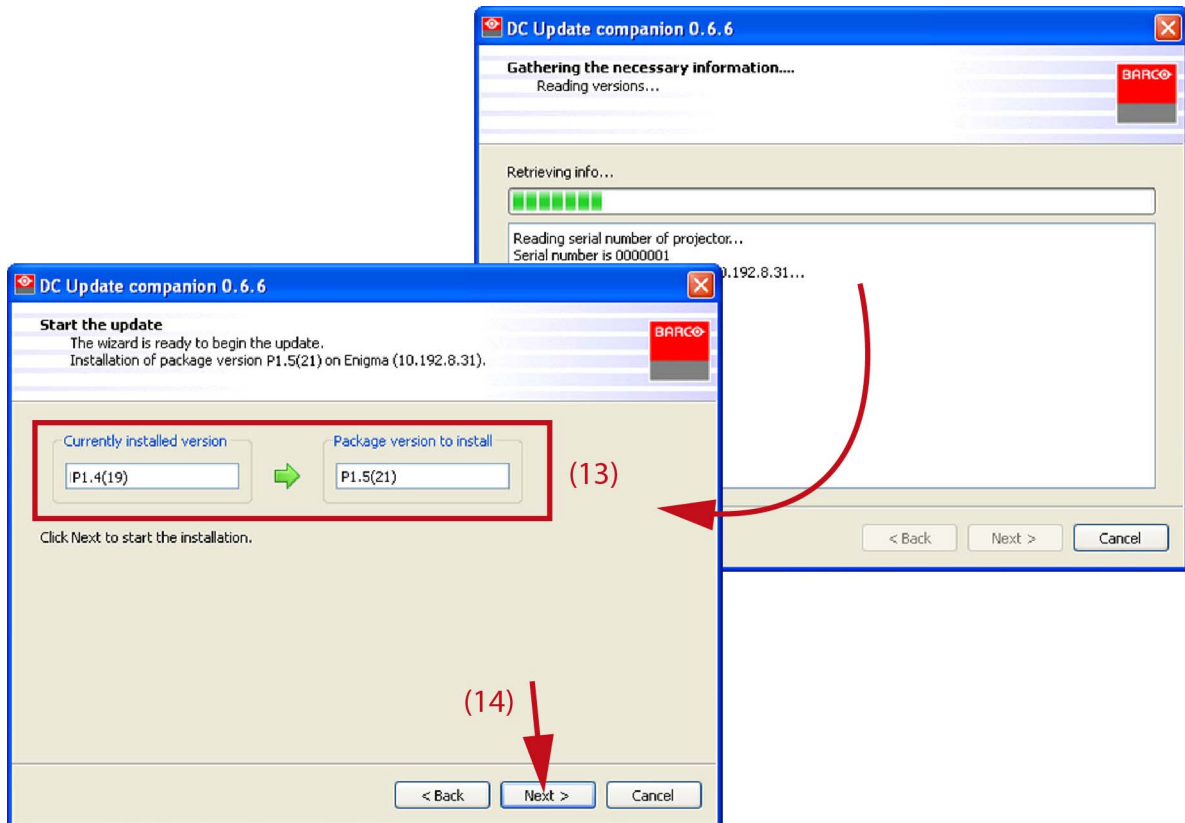

Image 14-13

- Click **Next** to start the software update (14).
When the update is finished, an status window is displayed.

14.5 Update logging

Installation logging

When the software update is finished, a status window is displayed. This window is almost equal for all possible updates.

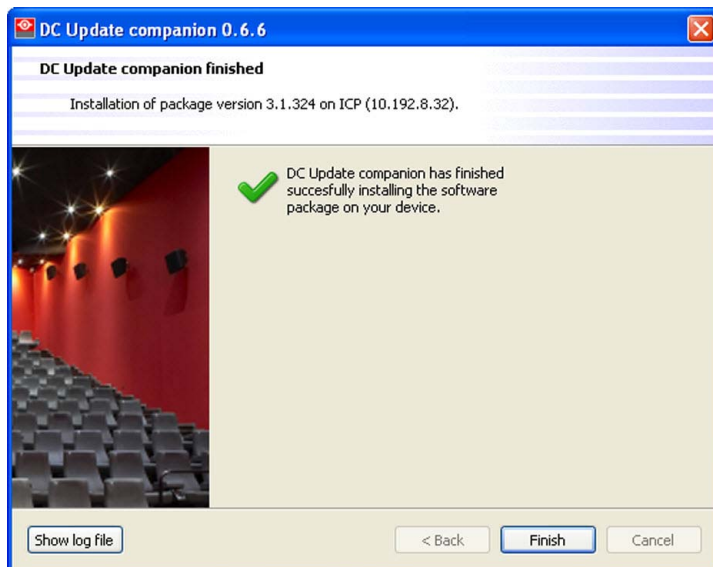

Image 14-14
Status window.

To show the log file, click on **Show log file**.

All information about the update process is logged in this log file.

15. COMMUNICATOR TOUCH PANEL

Overview

- Introduction
- Installing the touch panel interface
- Reposition the touch panel interface

15.1 Introduction

Communicator Touch Panel for digital cinema projectors

The Communicator Touch Panel is designed for multi-user command and control, the Communicator enables users to learn quickly and operate efficiently - using an elegant and flexible touch panel interface. The interface's commonality means that operators can intuitively use any model in the product line, without restriction, and its user-friendly nature translates directly into a short and enjoyable learning curve.



Image 15-1

Flexible touch panel interface

The touch panel interface can be mounted upon a swivel arm which easily fits on top of the DP2K-12C/11CX projector. One central locking mechanism of the swivel arm allows an instant fixation of the touch panel interface in any position.

The touch panel interface can also be installed further away from the DP2K-12C/11CX projector. For that you can use a serial (RS232) cable up to 10 meter or an Ethernet cable up to 50 meter to realize a direct data communication between the DP2K-12C/11CX projector and the Communicator Touch Panel.

The touch panel interface can also be connected with a Local Area Network (LAN) just like the DP2K-12C/11CX projector. In this case both devices can communicate with each other as well.

The touch panel interface requires a voltage supply +12 VDC and 1,5 ampere. Note that the DP2K-12C/11CX projector has a 12 VDC output which can be used to power up the touch panel interface. Nevertheless, the use of a separate +12 VDC adaptor (1,5 ampere minimum) is required in case the touch panel interface is installed more than a few meters away from the DP2K-12C/11CX projector.



A crossed DC cable has to be used when connecting the +12 VDC output from the Input & Communication unit of the DP2K-12C/11CX projector directly with the Touch Panel interface.

Parts location of the touch panel interface

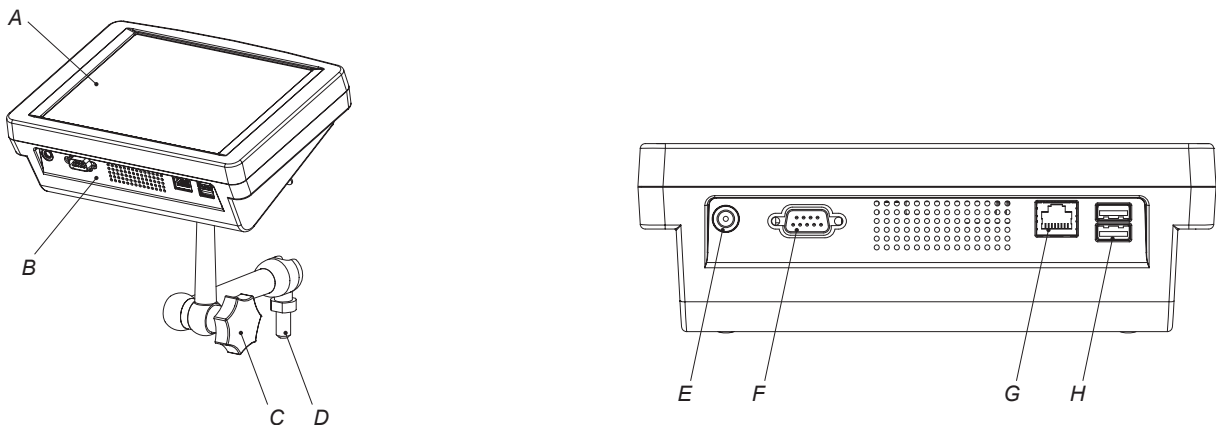

Image 15-2

- A Touch screen.
- B Communication ports.
- C Knob to operate central swivel clamp.
- D Base of swivel arm.
- E Power input (12 VDC - 1,5 A).
- F RS323 port (9 pins SUB-D).
- G Ethernet port (RJ45).
- H Two USB ports to connect USB stick, mouse or keyboard.



CAUTION: Refer to the user guide of the Communicator Touch Panel for more information about usage guidelines.

15.2 Installing the touch panel interface

Necessary tools

- 17 mm wrench.
- 10 mm wrench.

How to install the touch panel interface upon the DP2K-12C/11CX?

1. Assemble the mounting plate and the swivel arm together as illustrated. First place the nut (N) upon the rod of the mounting plate, then add the lock washer (L), then fasten the mounting plate and the swivel arm together. When the arm is mounted, turn nut (N) against the arm to secure the position.

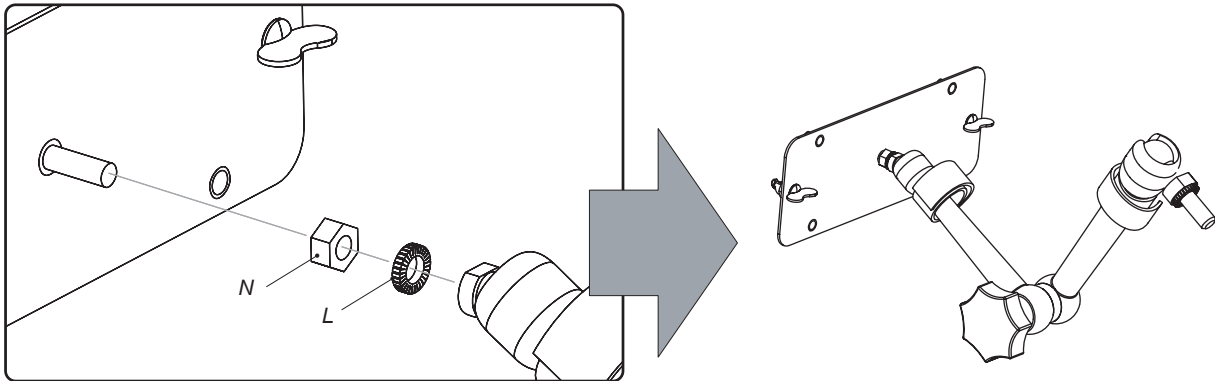

Image 15-3
Assemble swivel arm

2. Slide a washer (M) over the base of the swivel arm and insert the base of the swivel arm into the mounting hole at the top of the DP2K-12C/11CX as illustrated.

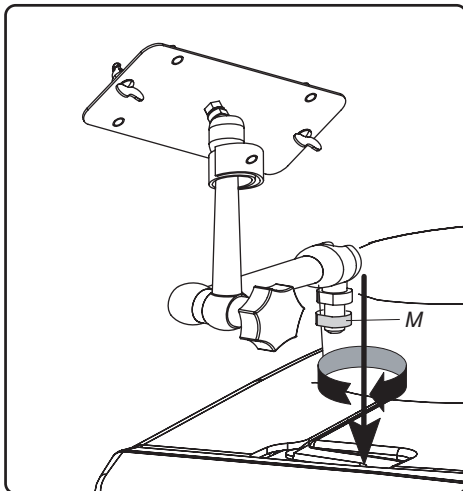

Image 15-4
Mount swivel arm

3. Place the touch panel interface upon the mounting plate of the swivel arm and fasten the two wing nuts (W) as illustrated.

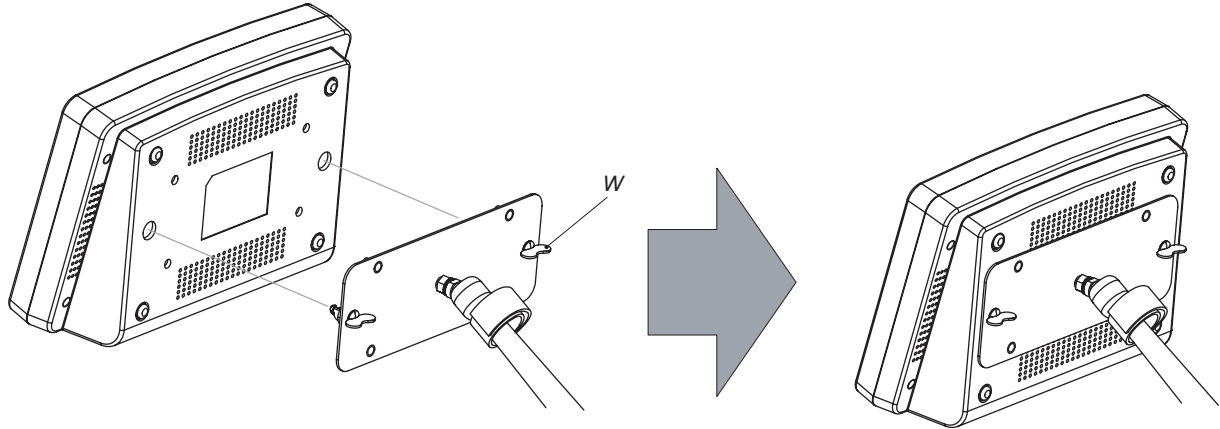

Image 15-5
Mount touch panel

4. Connect the circular plug of the multi cable with the circular socket at the rear side of the DP2K-12C/11CX.

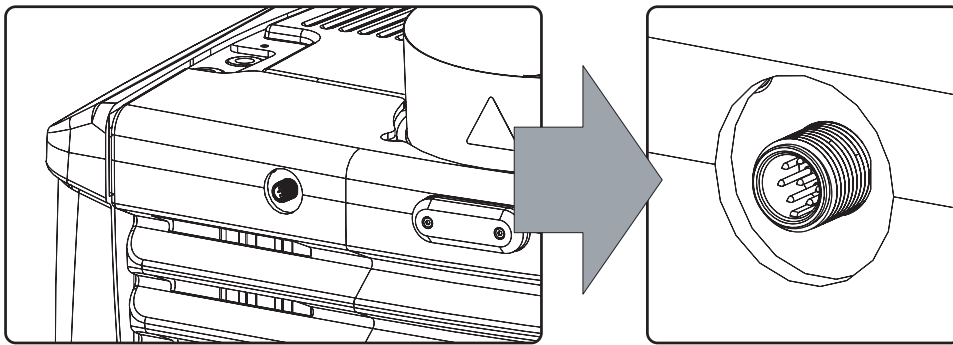

Image 15-6
Connections

5. Attach the multi cable to the swivel arm using the two Velcro strips.
6. Connect the DC plug, the RJ45 Ethernet plug and the D-SUB plug into their respective sockets on the touch panel interface.

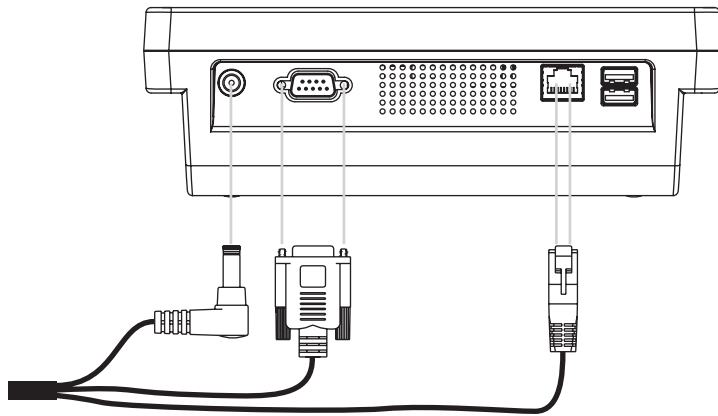

Image 15-7
Connections

15.3 Reposition the touch panel interface

How to reposition the touch panel interface?

1. Hold fast the touch panel interface.
2. Release the central swivel clamp by turning the big black knob (K) counterclockwise.

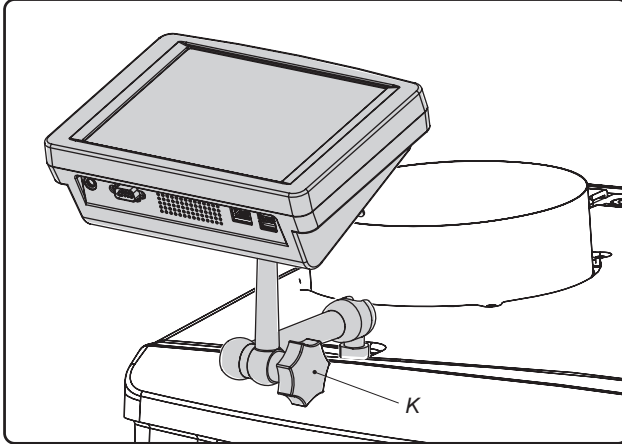

Image 15-8

3. Move the touch panel interface into the desired position.
4. Fasten the central swivel clamp by turning the big black knob clockwise.



CAUTION: Never release the central swivel lock without supporting the Touch Panel interface.

16. POWER INPUT

About this chapter

This chapter describes the procedures to replace the power input components such as main switch, mains filter, ...



WARNING: Always disconnect the power cord from the local power net before start any service action on the Mains Input of the projector.

Overview

- Introduction
- Getting access to the Mains Input components
- Replacement of the mains ON/OFF switch
- Replacement of the mains input filter
- Closing the Mains Input compartment

16.1 Introduction

Power Input

The power input of the projector is located at the rear side of the projector. The electrical connection with the local power net is fixed wired. The local power net is connected with a built-in 3-terminal strip. The power is applied to the mains filter via the mains switch. Two power cables are connected with the output side (LOAD) of the mains filter. One cable leads via the 5,5 ampere protected C13 power output socket and a C14 power input socket to the SMPS and is used to provide the electronics of the projector with power. The other cable goes to the Lamp Power Supply module. By default the power output and input socket are connected with a short power cable. When an Uninterrupted Power Supply (UPS) is required, the short cable is removed and the UPS is connected to the power input C14 socket.

Power Input parts location

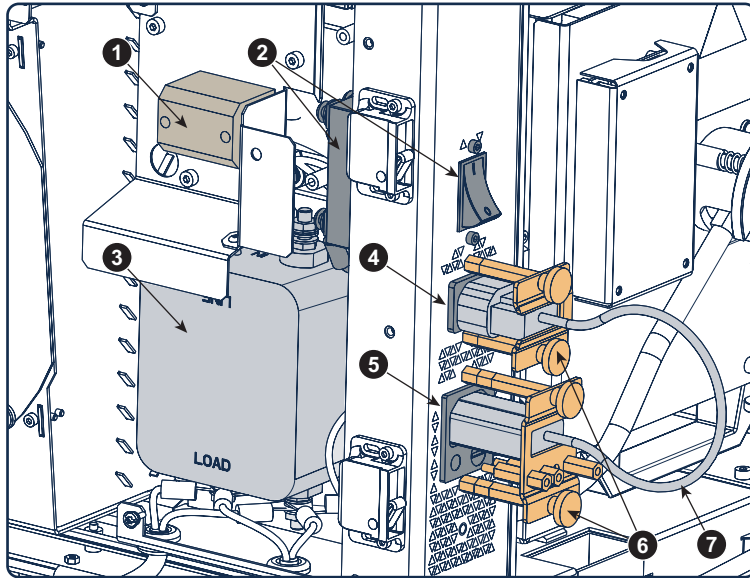

Image 16-1
Power input

- 1 Terminator block.
- 2 Automatic circuit breaker with ON/OFF switch.
- 3 Mains input filter.
- 4 Power input C14 socket for projector electronics (UPS purpose).
- 5 Protected power output C13 socket.
- 6 Adjustable brackets for securing the power plugs.
- 7 Loop through power cable.

16.2 Getting access to the Mains Input components



This procedure explains how to disconnect the power cord and how to remove the terminator block in order to get access to the mains filter and mains ON/OFF switch. This procedure assumes that the rear cover and lamp cover of the projector are already removed.

Necessary tools

- 3 mm Allen wrench.
- Flat blade screw driver.
- Torx screw driver T20

How to get access to the Mains Input components?

1. Make sure that the power cord of the projector is powerless.
2. Remove the cover of the AC compartment by releasing the three captive dumb screws.

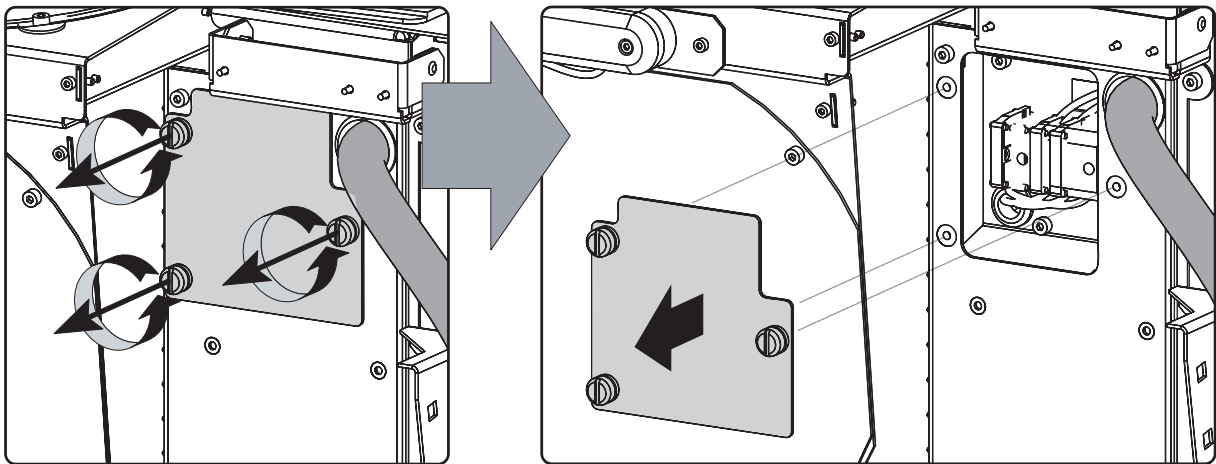

Image 16-2
AC power compartment cover

3. Disconnect the AC power cord from the 3-terminal strip and guide the AC power cord out of the compartment.
4. Remove the cover plate by releasing the 3 hexagon socket head cap screws and the 2 Torx screws as illustrated.

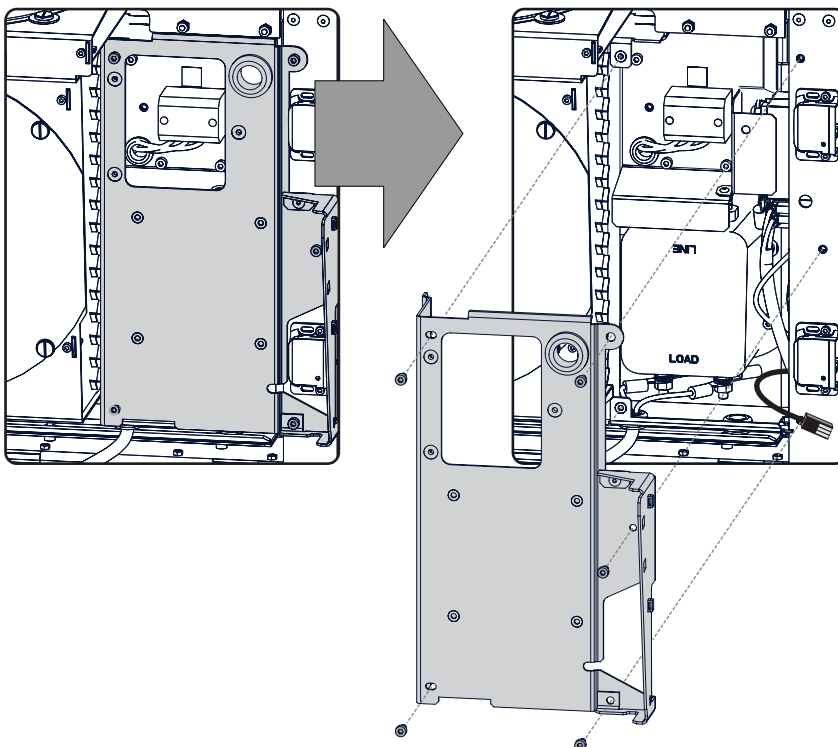

Image 16-3
Mains input cover

16. Power input

5. Disconnect the three wires from the 3-terminal strip. Use a flat blade screw driver.
6. Remove the 3-terminal strip together with its mounting plate by releasing the 4 hexagon socket head cap screws as illustrated. Use a 3 mm Allen wrench.

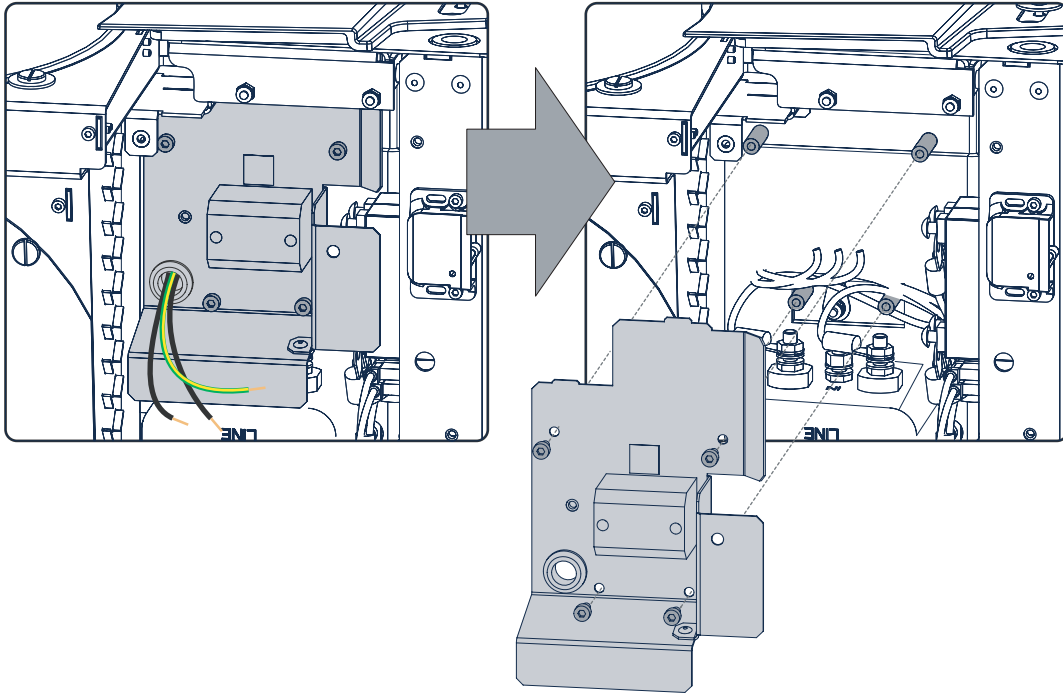

Image 16-4
Mains input strip

16.3 Replacement of the mains ON/OFF switch



This procedure assumes that the Mains Input components are accessible.

Necessary tools

- 2,5 mm Allen wrench.
- Flat blade screw driver.

How to replace the mains ON/OFF switch

1. Remove the two hexagon socket head cap screws which securing the ON/OFF switch. Use a 2,5 mm Allen wrench. Note that the ON/OFF switch is still connected with the mains input filter. Once the switch is detached from the projector chassis it will be easier to disconnect the wires as described in the next step.

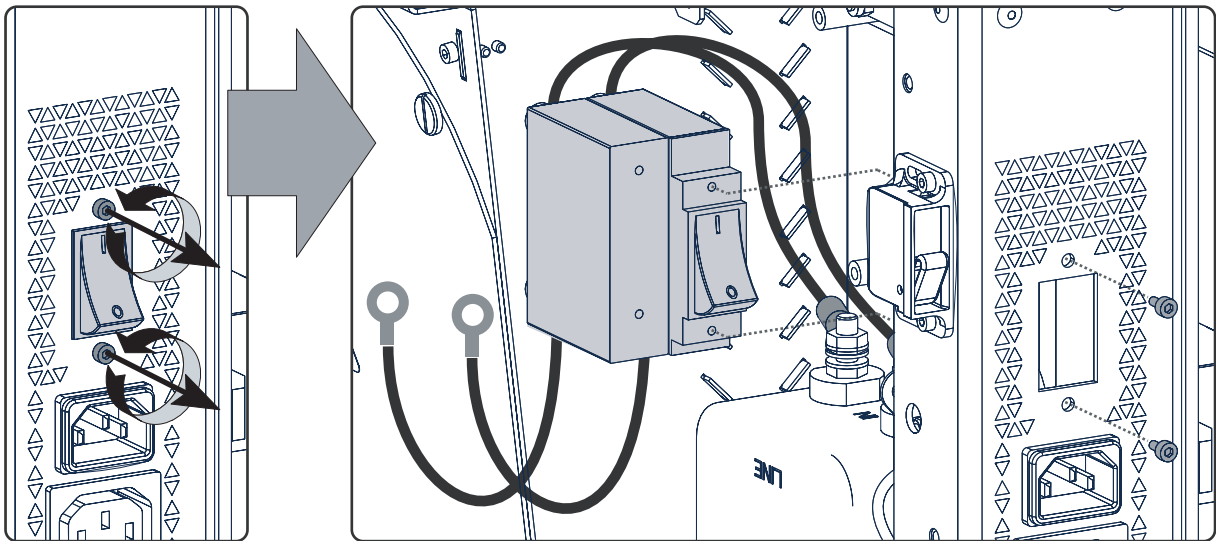

Image 16-5
ON/OFF switch assembly removal

2. Remove the connection screws at the back side of the ON/OFF switch and slide off the eye connectors. Do not drop the washers inside the projector. Use a flat blade screw driver.
3. Connect the two wires from the mains filter (reference 3 image 16-6) with the two upper pins of the ON/OFF switch. Slide a lock washer followed by a washer over the screw and then the eye connector of the wire. Turn in the screw and tighten completely.
Note: The top side of the ON/OFF switch is the upper side when holding the ON/OFF switch vertically with the indication "1" (reference 1 image 16-6) points to the top of the projector.
4. Connect the two loose wires (reference 2 image 16-6) with the two lower pins of the ON/OFF switch. Slide a lock washer followed by a washer over the screw and then the eye connector of the wire. Turn in the screw and tighten completely.

16. Power input

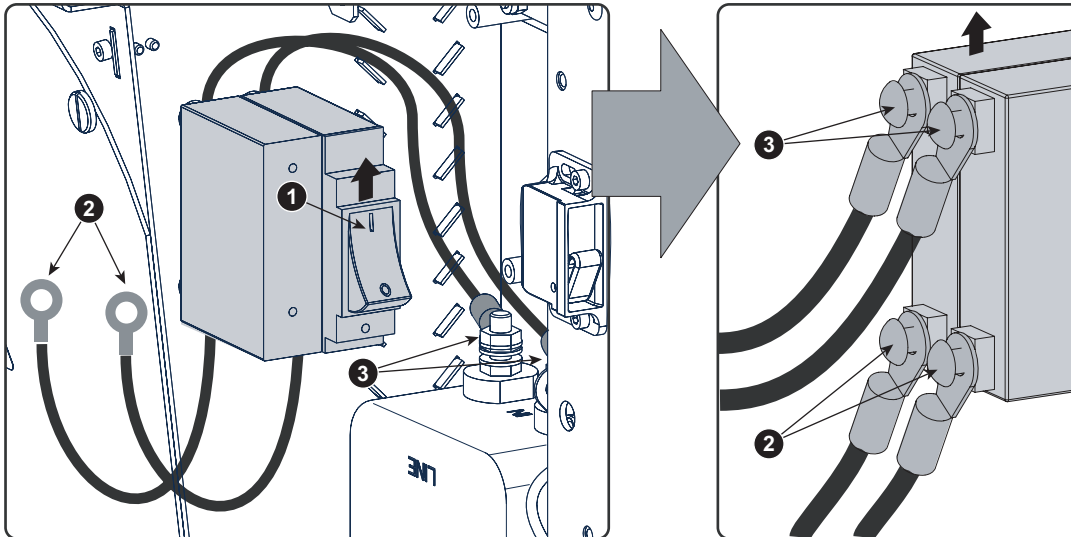

Image 16-6
Connections with main switch

5. Slide the new ON/OFF switch from the inside of the projector through the cabinet. Make sure that the indication "1" (reference 1) points to the top of the projector.

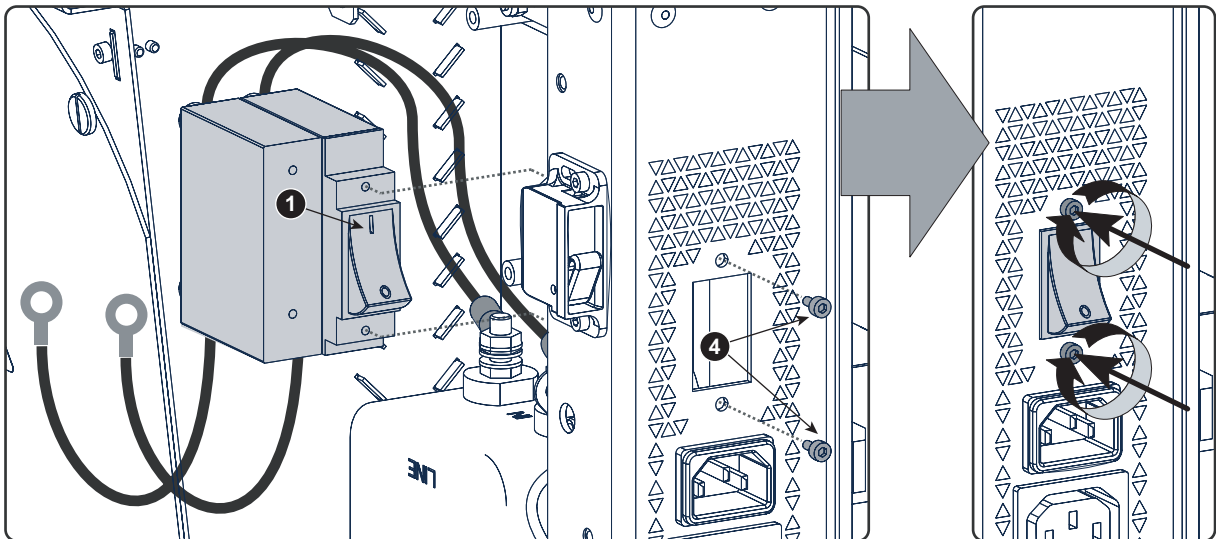

Image 16-7
Mount Main switch assembly

6. Fasten the ON/OFF switch with two hexagon socket head cap screws (reference 4 image 16-7).

16.4 Replacement of the mains input filter



This procedure assumes that the Mains Input components are accessible.

Necessary tools

- 3 mm Allen wrench.
- 10 mm open-end wrench.

How to replace the mains input filter

1. Remove both nuts on the "LOAD" side (reference A and B of image 16-8) of the mains input filter and slide off all eye connections. Do not drop the lock washers in the projector. Use a 10 mm open-end wrench.
2. Remove both nuts on the "LINE" side (reference C and D of image 16-8) of the mains input filter and slide off all eye connections. Do not drop the lock washers in the projector. Use a 10 mm open-end wrench.

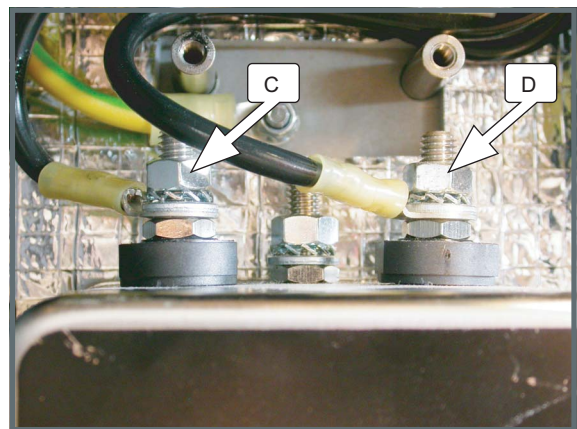
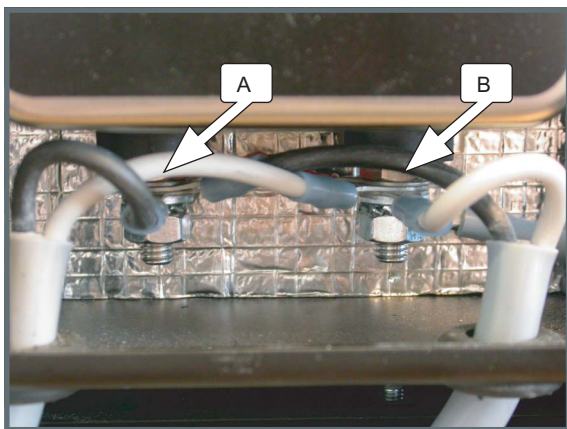

Image 16-8
LOAD connections

3. Remove the mains input filter by releasing the four hexagon socket head cap screws as illustrated. Use a 3 mm Allen wrench.

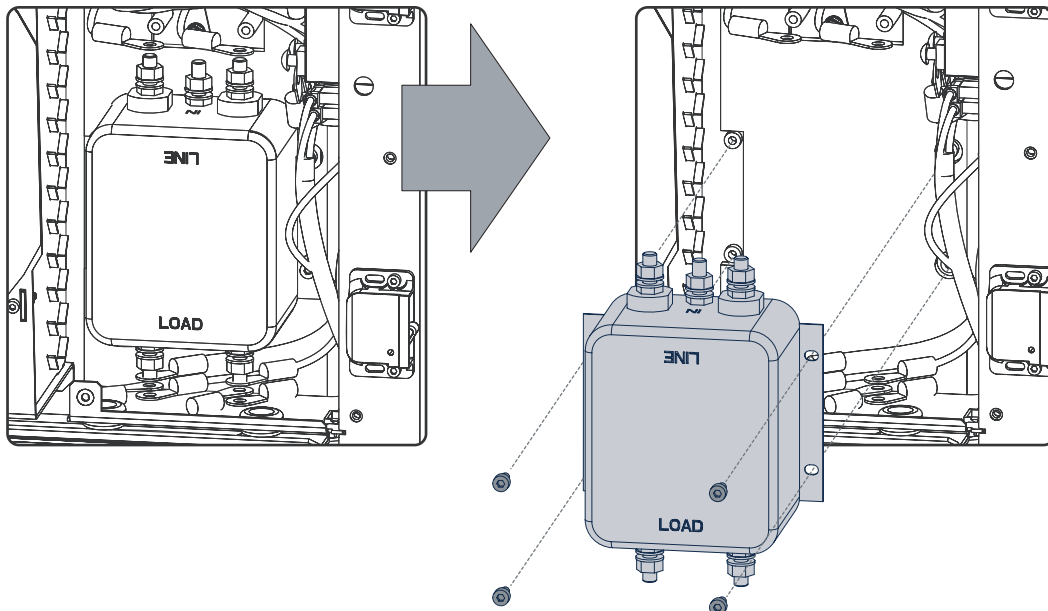

Image 16-9
Mains input filter removal

4. Place a new mains input filter on its position and fasten with four hexagon socket head cap screws. Make sure that the "LOAD" side is facing downwards. Use a 3 mm Allen wrench.
5. Connect the wires with the same colors of the LPS cables and the wire from the mains output with the "LOAD" side of the mains input filter (reference A and B of image 16-8). First slide the eye connections of the wires over the pin (same colors together), then slide a washer followed by a lock washer over the pin and secure with a nut. Use a 10 mm open-end wrench.

16. Power input

6. Connect both wires (reference C and D of image 16-8) from the ON/OFF switch with the "LINE" side of the mains input filter. First slide the eye connections of the wire over the pin, then slide a washer followed by a lock washer over the pin and secure with a nut. Use a 10 mm open-end wrench.

16.5 Closing the Mains Input compartment

Necessary tools

- 3 mm Allen wrench.
- Flat blade screw driver.
- Torx screw driver T20

How to close the Mains Input compartment?

1. Guide the ground wire and the two wires from the ON/OFF switch through the opening in the mounting plate of the 3-terminator strip and secure the mounting plate with four hexagon socket head cap screws as illustrated.

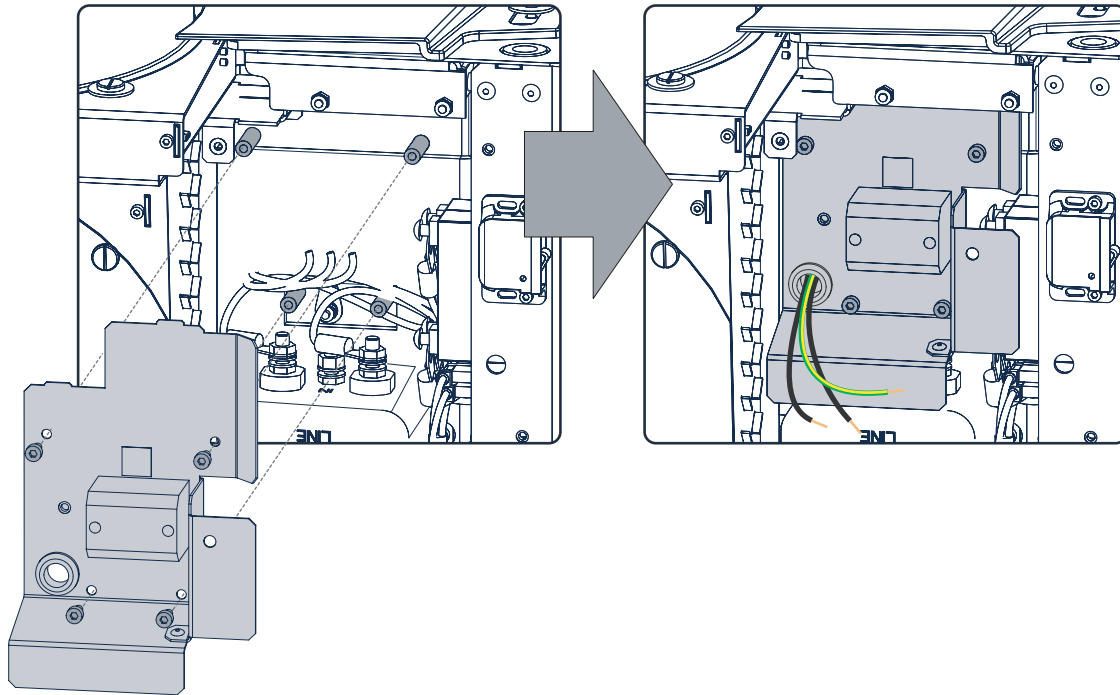

Image 16-10

2. Connect the ground wire and the two wires from the ON/OFF switch with the lower pins of the 3-terminator strip. Make sure to connect the ground wire with the marked ground pin of the 3-terminator strip.
3. Fasten the cover plate with 3 hexagon socket head cap screws and 2 Torx screws as illustrated.

16. Power input

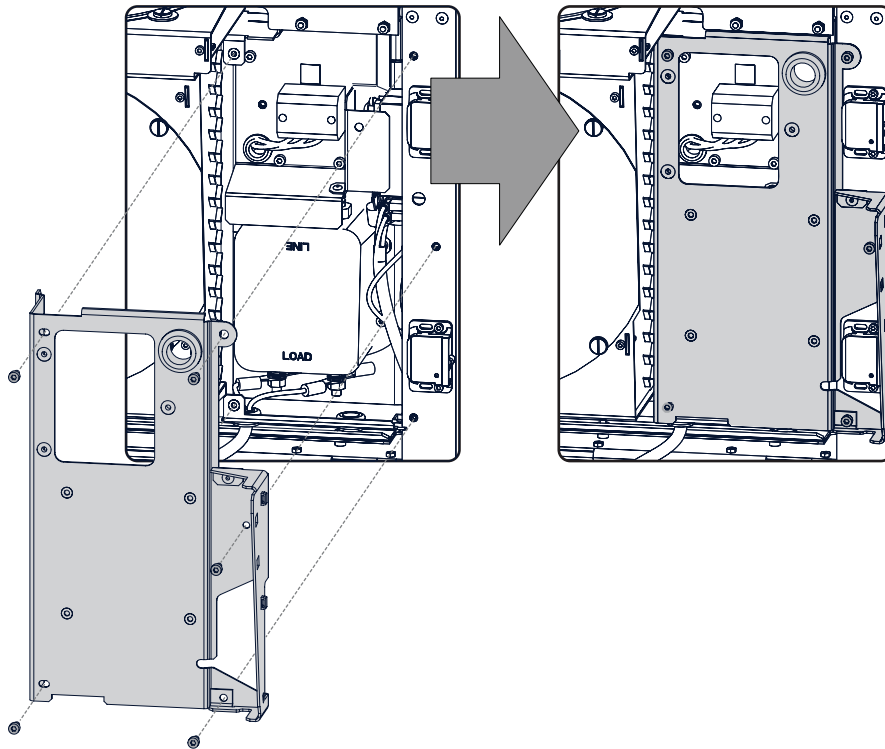

Image 16-11
Mains input cover, installation

4. Guide the AC power cord through the cable gland and connect the wires to the 3-terminal strip as illustrated.
Warning: Always connect first the ground wire (PE).

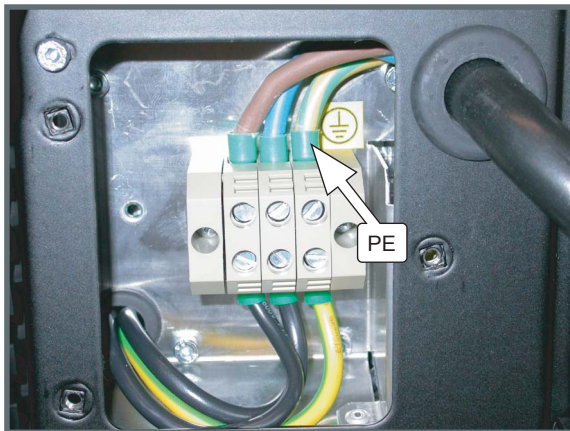

Image 16-12
Wire connections

5. Reinstall the cover of the main AC compartment.

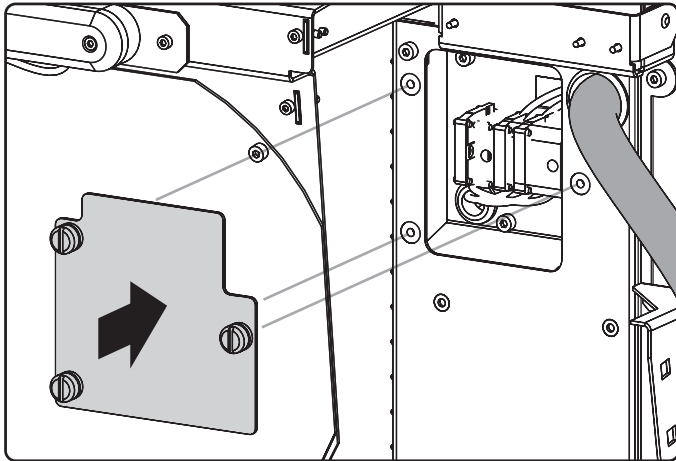
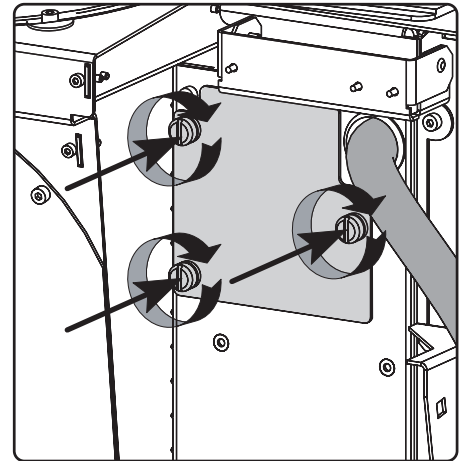

Image 16-13
Mains AC compartment cover



17. SWITCHED MODE POWER SUPPLY

Overview

- Diagnostic LEDs on the SMPS
- Replacement of the Switched Mode Power Supply

Preparations

Before getting access to the Switched mode power supply, remove the input cover.

17.1 Diagnostic LEDs on the SMPS

Diagnostic LEDs

Not that the projector input cover must be removed to see the LEDs.

+12V Indicates that the supply voltage of +12 volt is present for the electronics.

+ VTEC Indicates that the voltage to drive the Peltier elements (TEC), which are mounted on the Light Processor unit, is present

+24V Indicates that the supply voltage +24 volt is present.

17.2 Replacement of the Switched Mode Power Supply

Necessary tools

- 7 mm nut driver or
- flat screw driver

How to replace

1. Release the 4 spring locks (1).

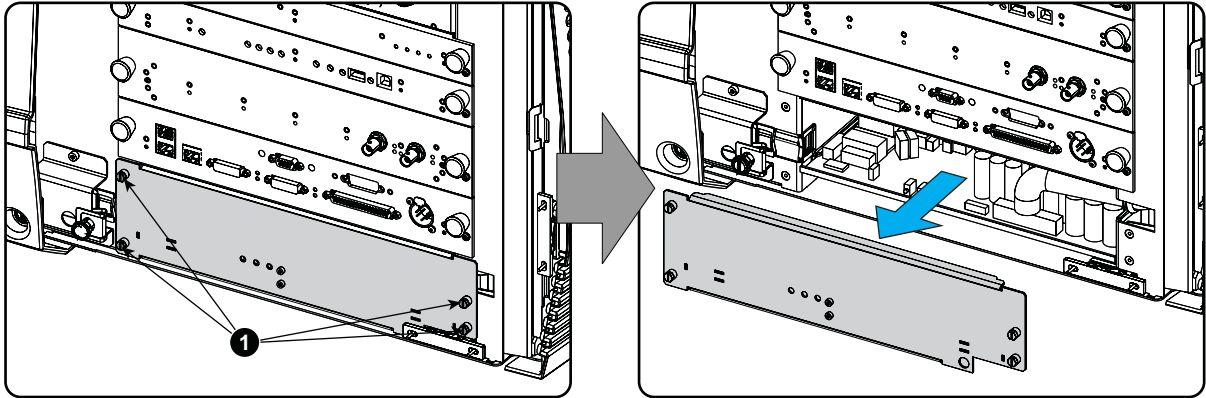

Image 17-1
SMPS cover

2. Take off the cover.

3. Disconnect the following connectors:

- Mains input (1)
- Ground wire (2)
- Control connector (blue wires) (3)
- Power out connector (black wires) (4)

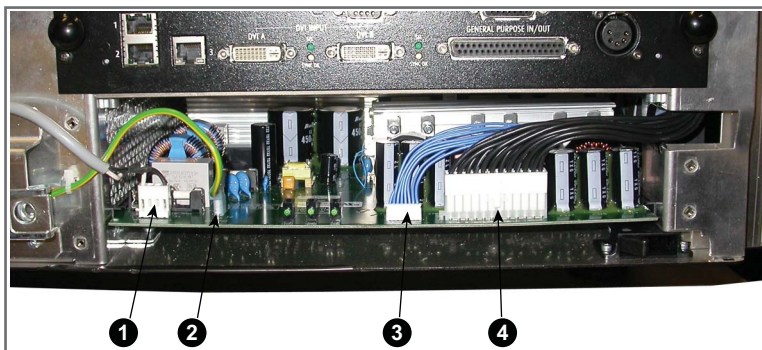

Image 17-2
SMPS connections

4. Slide out the Switched Mode Power Supply board.

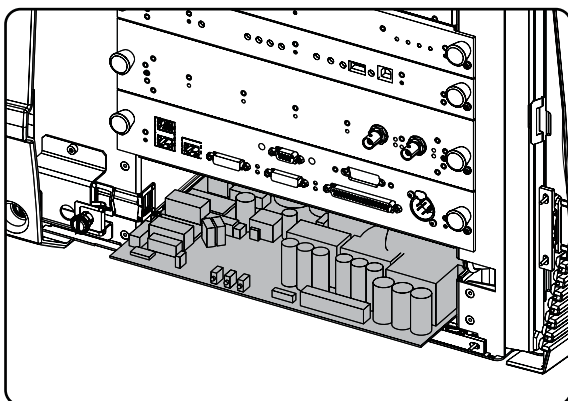

Image 17-3

5. Take a new unit and inset the board in the guides.
Pull it completely in.

17. Switched mode power supply

6. Make the electrical connections (image 17-2):
 - Mains input (1)
 - Ground wire (2)
 - Control connector (blue wires) (3)
 - Power out connector (black wires) (4)
7. Place the cover on its place and secure with the 4 spring locks.

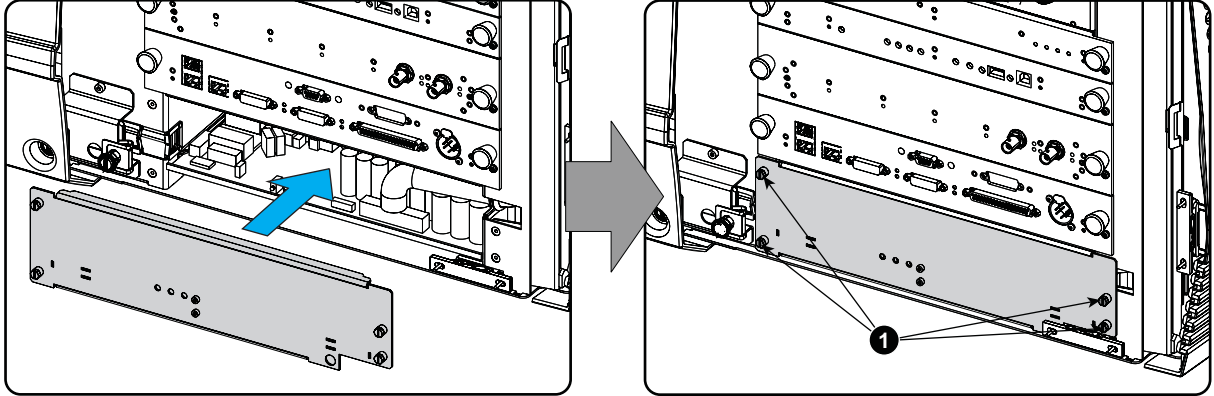

Image 17-4
Mount SMPS cover

18. LAMP POWER SUPPLY

About this chapter

This chapter describes briefly the functionality, the different parts, the diagnostic LED's and the replacement of the Lamp Power Supply (LPS).

Overview

- Introduction
- LPS diagnostic LED's
- Removal of the LPS module
- Installation of the LPS module

Preparations

Remove first the rear cover of the projector, see "Removal of the rear cover", page 82.

18.1 Introduction

Functionality of the Lamp Power Supply

The front side of the LPS casing contains the input/output connectors and diagnostic LED's of the LPS unit. The rear side is equipped with fans. The whole LPS module slides into the LPS compartment at the rear bottom of the projector and can be replaced easily.

To ignite the lamp the voltage on the output pins of the LPS unit is brought up to 140 volt. This high voltage will trigger the Start Pulse Generator (SPG) to ignite the lamp. Once the lamp is ignited the voltage on the output pins of the LPS unit is dropped to the typical arc voltage of the lamp.

Parts

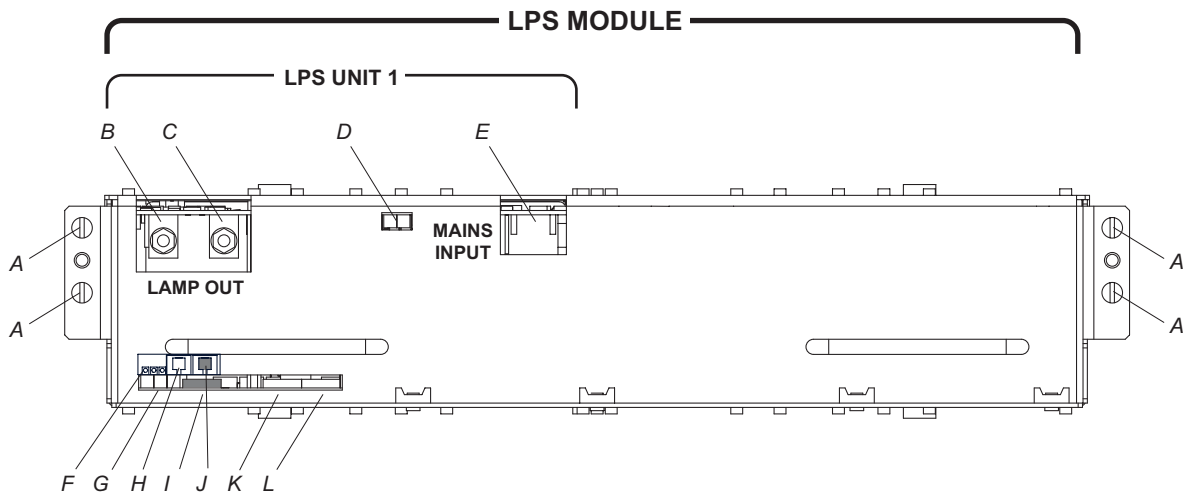

Image 18-1

- | | |
|---|---|
| A Captive screw. | G Status LEDs: "ERR", "PFC OK" & "LPS OK". |
| B Lamp output pin "-". | H Socket for "CTRL OUT" cable - DP2K series. |
| C Lamp output pin "+". | I Socket for "ADDRESS" cable. |
| D Status LEDs: "LAMP ON / LVPS OK". | J Socket for CTRL IN" cable - DP2K series |
| E Mains input. | K Socket for "CTRL OUT" cable - not used in DP2K series. |
| F Status LEDs, left and middle LED for internal use, right LED : heartbeat | L Socket for CTRL IN" cable - not used in DP2K series |

18.2 LPS diagnostic LED's

Status LED's on LPS unit

The LPS module contains in total 8 status LEDs. Four orange, three green and one red LED.

The orange LED "LVPS OK" lights up immediately after the projector is switched on. At the same time, the heartbeat LED starts blinking. All other status LEDs of the LPS unit remain off. This is the standby status of the LPS unit. Once the command is sent to the LPS units to start up the projection lamp, the green LEDs are lighting up one after the other. First the green LED "PFC OK", then the green LED "LPS OK" and finally, when the lamp is ignited, the green LED "LAMP ON". The right orange of the upper row blinks. This is the heartbeat signal

The red LED "ERR" remains off unless an error is detected inside the LPS unit or when the LPS unit are ordered to shutdown due to a malfunction somewhere else inside the projector.

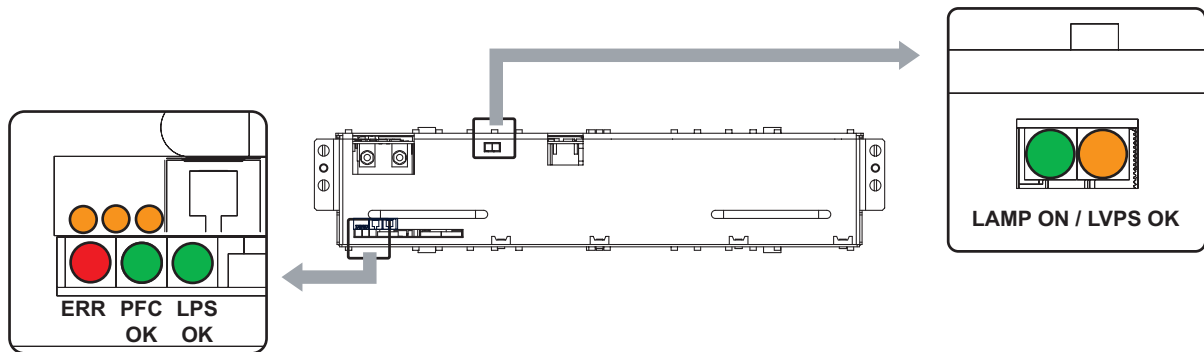

Image 18-2
LED indications

Diagnostic

About the orange LEDs next to the CTRL connectors:

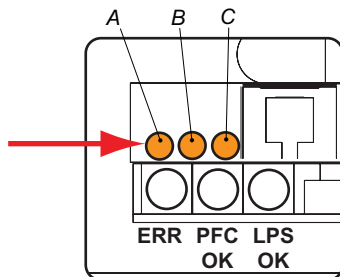

Image 18-3

LED A and B are only for internal use. LED C is the heartbeat LED.

| Orange LED C | Diagnostics | Action |
|--------------|---|-----------------------------|
| Blinking | Normal operation | - |
| OFF | 12 V from backplane via CTRL IN not available on LPS unit | Check 12V out on backplane. |
| ON | 12 V from backplane available. | Replace the LPS module. |

About the diagnostic LEDs, ERR, PFC, LPS, Lamp ON and LVPS.

| Orange | Green | Green | Green | Red | Diagnostic | Action |
|---------|--------|--------|---------|-----|----------------------------|--------------------------|
| LVPS OK | PFC OK | LPS OK | LAMP OK | ERR | | |
| OFF | OFF | OFF | OFF | OFF | No input voltage. | Switch on the projector. |
| ON | OFF | OFF | OFF | OFF | Standby modus of LPS unit. | — |

18. Lamp power supply

| Orange | Green | Green | Grreen | Red | Diagnostic | Action |
|---------|--------|--------|---------|----------|---|---|
| LVPS OK | PFC OK | LPS OK | LAMP OK | ERR | | |
| ON | ON | ON | OFF | OFF | PFC and LPS seems to work normally but the lamp is not ignited. This situation can be the result of a bad lamp or SPG module. | <ul style="list-style-type: none"> • Install another DP2K-12C/11CX lamp house in case the voltage on the "LAMP OUT" pins is > 140 volt for a short time (few seconds). • Replace the SPG module in case the voltage value on the "LAMP OUT" pins is >140 volt and you do not hear the SPG module clicking to ignite the lamp. • Replace the LPS module in case the voltage value on the "LAMP OUT" pins is below 140 volt and the lamp is not ignited. |
| ON | ON | ON | ON | OFF | LPS unit is operating normally. Projector lamp is ignited. | — |
| ON | OFF | OFF | OFF | ON | LPS internal temperature is too high. | <ul style="list-style-type: none"> • Check if the LPS air inlet at the bottom side of the projector is not blocked. • Check if the air outlet at the rear of the projector is not blocked. • If the problem remains, replace the whole LPS module. |
| ON | OFF | OFF | OFF | Flashing | Error detected inside this LPS unit. | Replace the LPS module. |

18.3 Removal of the LPS module

Necessary tools

- 6 x 120 mm flat screw driver.
- 10 mm nut driver.

How to remove the LPS module

1. Remove the back cover of the projector.
2. Disconnect the "MAINS INPUT" from the LPS units.

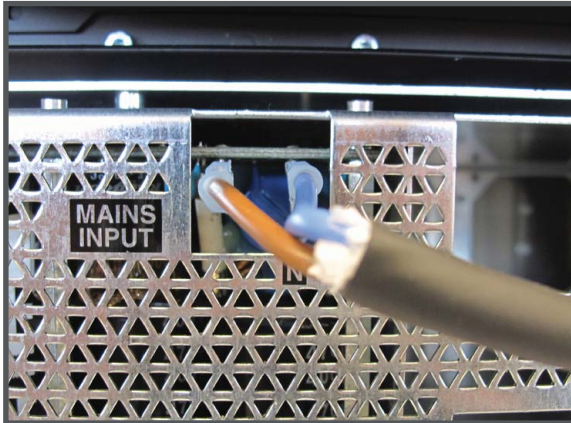

Image 18-4
Mains input

3. Disconnect the wire unit from the "CTRL IN" socket of LPS unit.



Image 18-5
CTRL in connector

4. Disconnect both "LAMP OUT" power cables from the LPS module. Use a 10 mm nut driver.

Caution: Do not loose the washers which fit between the fixation nuts and the cable eye.

Tip: Place the washers and nuts back upon the output pins.

18. Lamp power supply

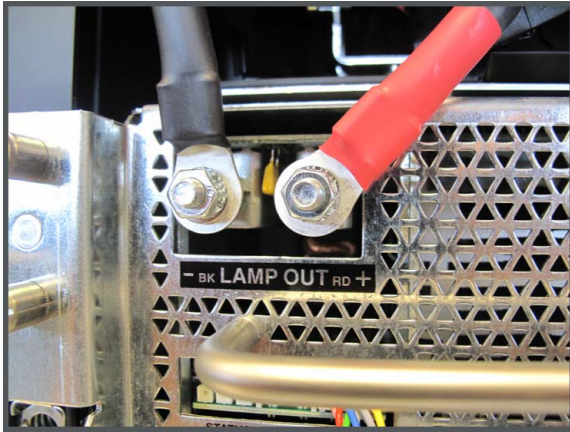

Image 18-6
Lamp out connection

5. Release the four captive screws which fasten the LPS module to the projector chassis. Use for that a flat screwdriver (6 x 10 mm).

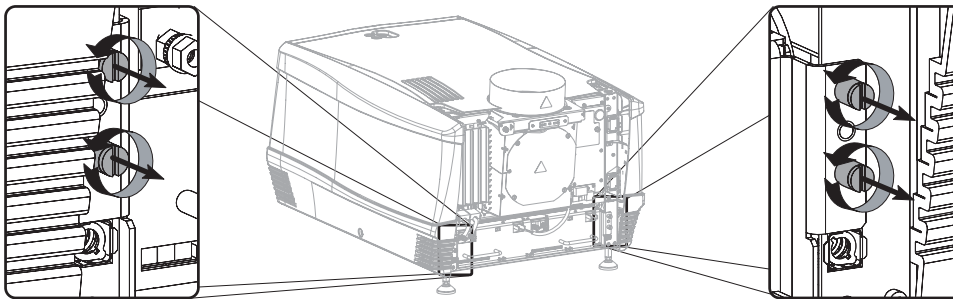

Image 18-7
LPS module fixation

6. Hold fast the LPS module by its handles pull the LPS module out of its compartment.

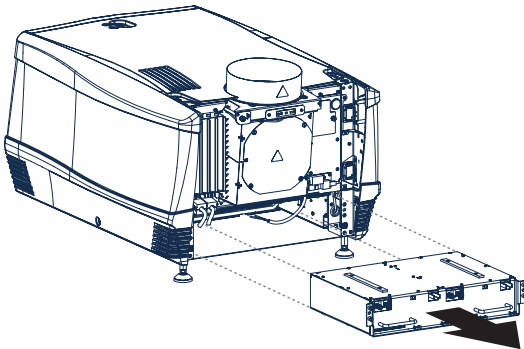

Image 18-8
Remove LPS module

7. Remove the ADDRESS cable and save it to reuse on the new unit.

18.4 Installation of the LPS module

Necessary tools

- 6 x 120 mm flat screwdriver.
- Torque wrench with a 10 mm hexagon socket.

How to install the LPS module

1. Slide the LPS module into its compartment as illustrated.

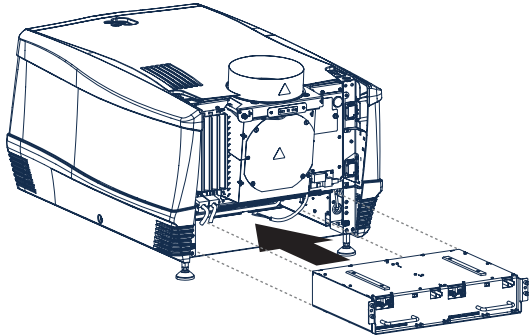

Image 18-9
Insert LPS module

2. Fasten the four captive screws of the LPS module.

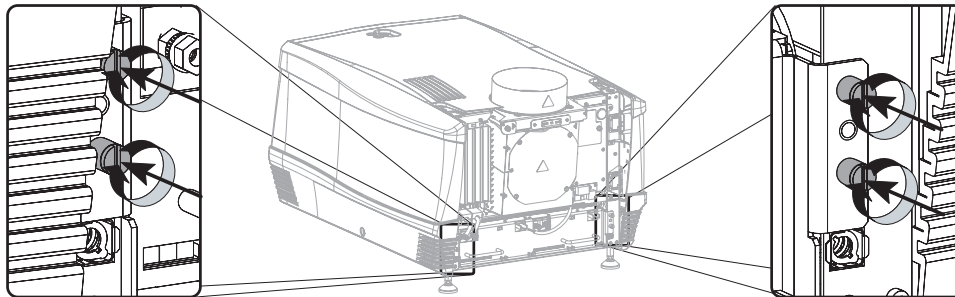

Image 18-10
Fixate LPS module

3. Connect the power cables coming from the SPG module with the "LAMP OUT" sockets of the LPS module as illustrated. Fasten the nuts with a torque of **4Nm** (2.95 lb*ft).

Warning: Make sure to place the washers and cable eye in correct order upon the pin as illustrated. Always use a plain washer between the output pin and the cable eye.

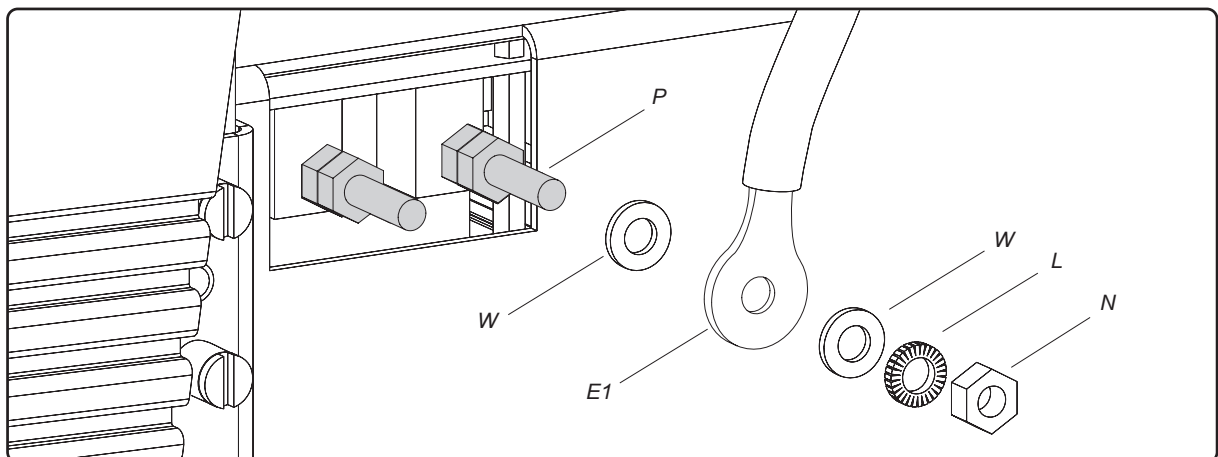

Image 18-11
Lamp out connection

- P LPS output pin.
- W Plain washer.
- L Lock washer.
- E1 Cable eye from SPG module.
- E2 Cable eye from LPS unit.
- N Nut.

Warning: Respect the polarity of the socket and cables. Red marked cables with the "+" pin, black marked cables with the "-" pin.

18. Lamp power supply

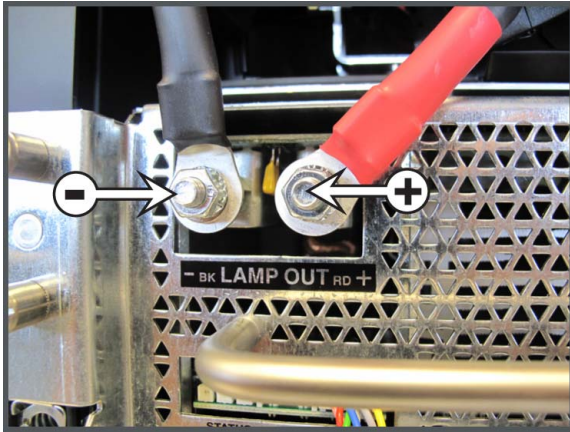

Image 18-12
Lamp power cables

4. Connect the controller wire unit with the "CTRL IN" socket of the LPS unit as illustrated.
5. Connect the mains input cables with the "MAINS INPUT" sockets of the LPS module as illustrated.
If a neutral 'N' indication is available, plug the connector of the blue wire into the socket labeled with N.

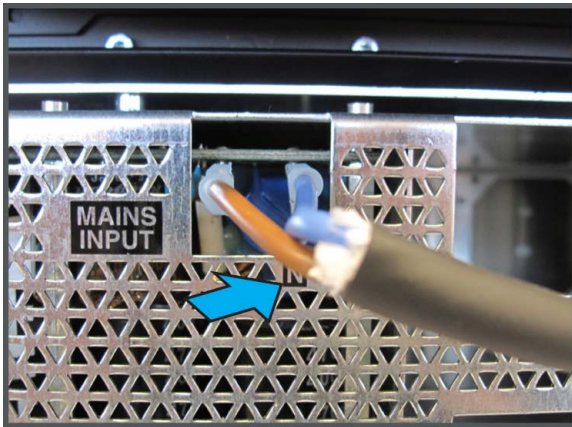

Image 18-13
Mains input connection and neutral indication (if available)

6. If not yet available, plug in the previously removed "ADDRESS" wire unit.

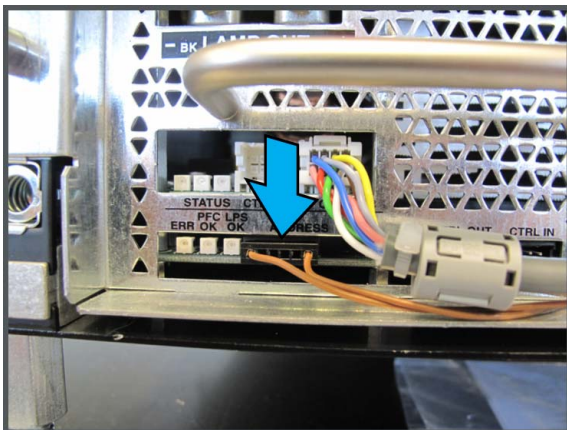

Image 18-14
Address connection

19. LAMP POWER SUPPLY (SINGLE MODULE)

Overview

- LPS module diagnostic LED's
- Removal of the LPS module
- Installation of the LPS module
- Replacing a large frame LPS with a single module LPS

19.1 LPS module diagnostic LED's

Status LED's on the LPS module

There are 8 diagnostic LED's per LPS module. Four orange, three green and one red LED.

The orange LED "LVPS OK" lights up immediately after the projector is switched on. At the same time, the heartbeat LED starts blinking. All other status LEDs of the LPS unit remain off. This is the standby status of the LPS unit. Once the command is sent to the LPS units to start up the projection lamp, the green LEDs are lighting up one after the other. First the green LED "PFC OK", then the green LED "LPS OK" and finally, when the lamp is ignited, the green LED "LAMP ON". The right orange of the upper row blinks. This is the heartbeat signal

The red LED "ERR" remains off unless an error is detected inside the LPS unit or when both LPS units are ordered to shutdown due to a malfunction somewhere else inside the projector.

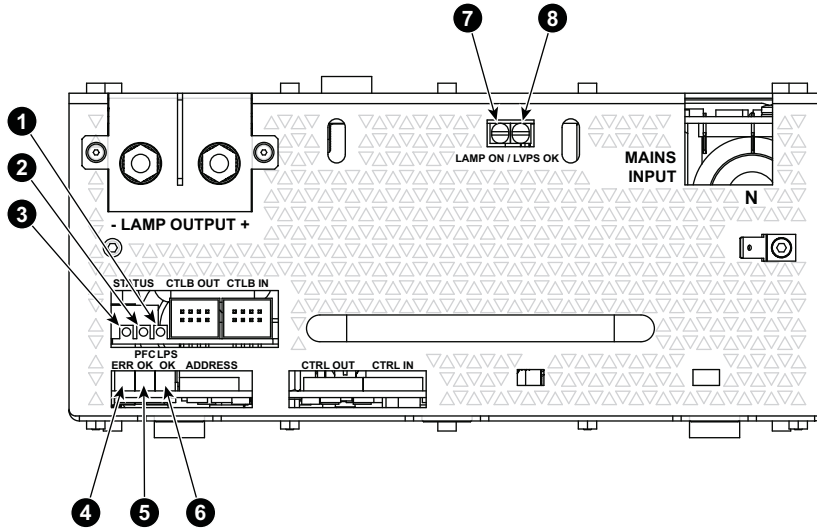

Image 19-1

- 1 Diagnostic LED "LPS HEARTBEAT" (orange).
- 2 (internal use only).
- 3 Diagnostic LED "LPS TRANS" (orange).
- 4 Diagnostic LED "ERROR" (red).
- 5 Diagnostic LED "PFC OK" (green).
- 6 Diagnostic LED "LPS OK" (green).
- 7 Diagnostic LED "LAMP ON" (green).
- 8 Diagnostic LED "LVPS OK" (yellow).

Diagnostic

About the orange LEDs next to the CTRL connectors:

LED 2 is only for internal use. LED 1 is the heartbeat LED.

| LPS HEARTBEAT (Orange LED 1) | Diagnostics | Action |
|---------------------------------|---|-----------------------------|
| Blinking | Normal operation | - |
| OFF | 12 V from backplane via CTRL IN not available on LPS unit | Check 12V out on backplane. |
| ON | 12 V from backplane available. | Replace the LPS module. |

| LPS TRANS (Orange LED 3) | Diagnostics | Action |
|-----------------------------|--|--|
| Blinking | Normal operation, blinks each time a valid transmission has been received | - |
| OFF or ON | Communication fault (no reception of valid commands from primary side) | Replace LPS unit |
| | Fault on primary side of LPS (E.g. fuse blown and no mains voltage available inside LPS) | Replace fuse. |
| | No mains voltage present at input of LPS mains terminals | If the problem is not solved, replace LPS Check main voltage. |

About the diagnostic LEDs, ERR, PFC, LPS, Lamp ON and LVPS.

| Orange | Green | Green | Green | Red | Diagnostic | Action |
|---------|--------|--------|---------|---------------|---|--|
| LVPS OK | PFC OK | LPS OK | LAMP OK | ERR | | |
| OFF | OFF | OFF | OFF | OFF | No input voltage. | Switch on the projector. |
| ON | OFF | OFF | OFF | OFF | Standby modus of LPS unit. | — |
| ON | ON | ON | OFF | OFF | PFC and LPS seems to work normally but the lamp is not ignited. This situation can be the result of a bad lamp or SPG module. | <ul style="list-style-type: none"> Install another xenon lamp in case the voltage on the "LAMP OUT" pins is 140 volt and you hear the SPG three times clicking to ignite the lamp. Replace the SPG module in case the voltage value on the "LAMP OUT" pins is >140 volt and you do not hear the SPG module clicking to ignite the lamp. Replace the LPS module in case the voltage value on the "LAMP OUT" pins is below 140 volt and the lamp is not ignited. |
| ON | ON | ON | ON | OFF | LPS unit is operating normally. Projector lamp is ignited. | — |
| ON | OFF | OFF | OFF | ON | LPS internal temperature is too high. | <ul style="list-style-type: none"> Check if the LPS air inlet at the bottom side of the projector is not blocked. Check if the air outlet at the rear of the projector is not blocked. If the problem remains, replace the whole LPS module. |
| ON | OFF | OFF | OFF | Flashing fast | Error detected inside this LPS unit. In case the other LPS unit operates normally the LPS module as a whole works at 50%. | Replace the LPS module. |
| | | | | Flashing slow | External error detected from Fan Control board. | Replace Fan Control board. |

Normal conditions of diagnostic LEDs when a lamp is switched ON

- LED 1 (Yellow right) : flashing (beating as a heart)
- LED 2 (Yellow center) : not defined
- LED 3 (Yellow left) : flashing few times / second
- ERR : OFF
- PFC OK : ON (green)
- LPS OK : ON (green)
- LAMP ON : ON (green)
- LVPS OK : ON (yellow/orange)

19.2 Removal of the LPS module

Necessary tools

- Flat screw driver
- Nut driver 10 mm

How to remove

1. Remove the **CTLB IN** (1) connection.

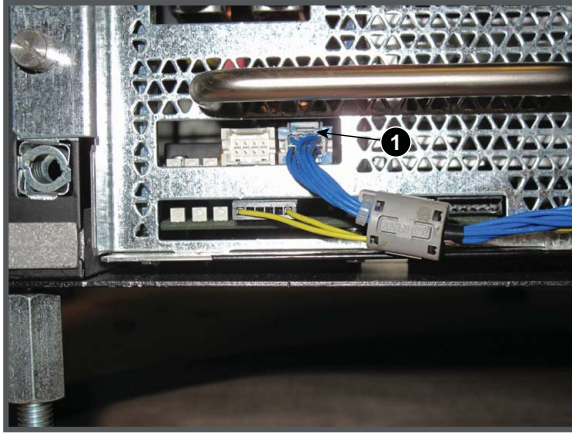

Image 19-2
Communication connection

2. Disconnect the **MAINS INPUT** cables (3).

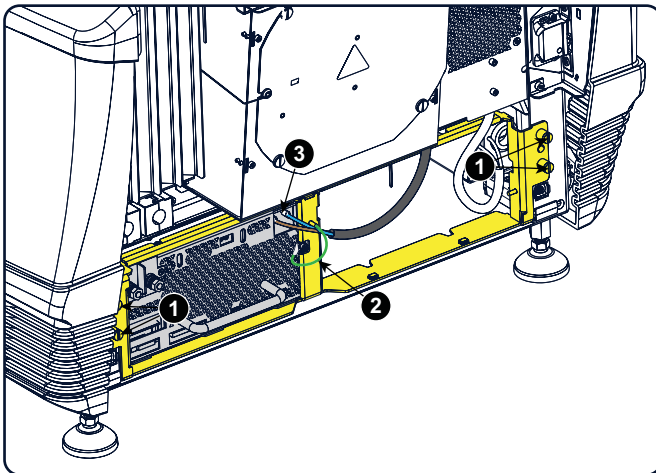

Image 19-3
Remove LPS

3. Disconnect the grounding wire (PE wires) (2, image 19-2).
4. Disconnect both **LAMP OUT** power cables. Use a 10 mm nut driver.
Caution: Do not loose the washers which fit between the fixation nuts and the cable eye.
5. Release the 4 captive screws (1, image 19-2) and take off the fixation frame.
6. Slide out the LPS module.

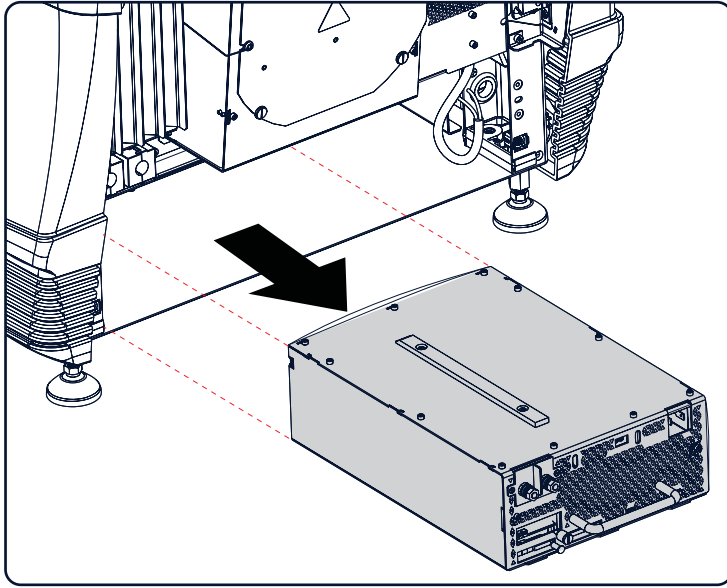

Image 19-4
LPS removal

19.3 Installation of the LPS module

Necessary tools

- Flat screw driver.
- Torque wrench with a 10 mm hexagon socket.

How to install

1. Before inserting the LPS unit, place the positioning pin at the backside to the right.

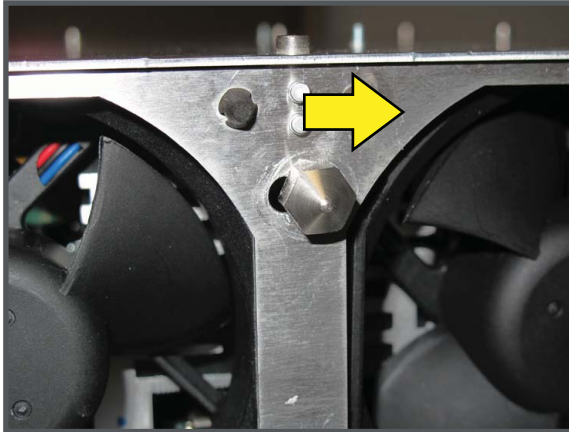

Image 19-5
Positioning pin

To move the pin to the right, pull on the pin and slide it to the right.

2. Slide a single LPS unit in the compartment at the left side.

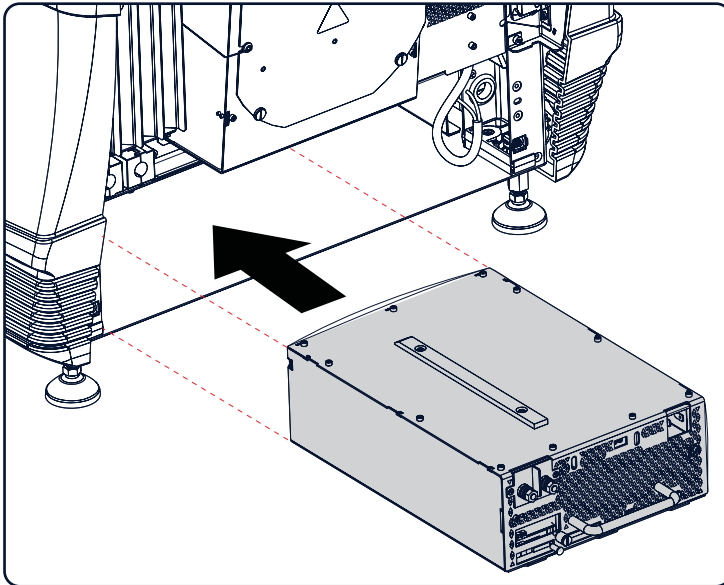

Image 19-6
Insert LPS unit

3. Slide the fixation frame on the front of the LPS unit in such a way that the fixation pins match the fixation holes.

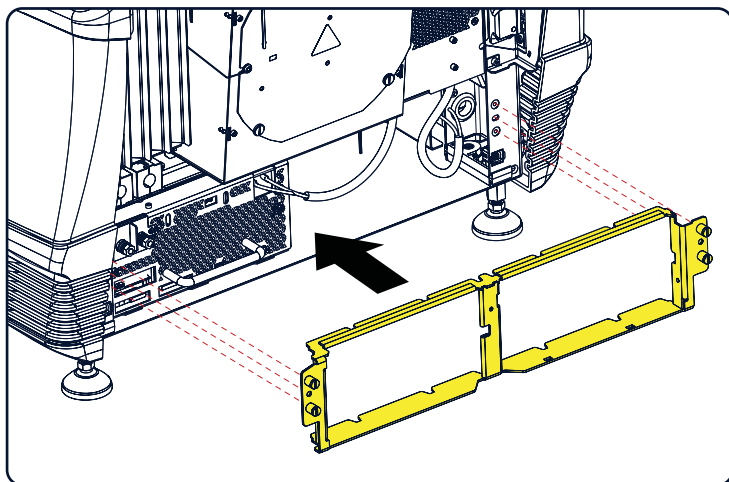

Image 19-7
Fixation frame

- Secure the 4 spring screws (1).

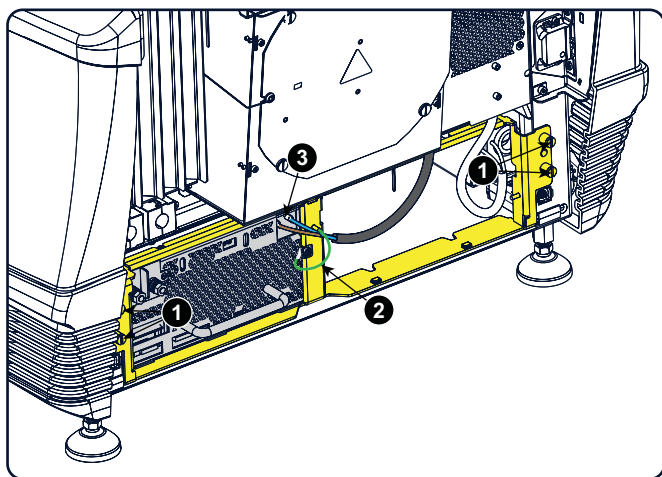

Image 19-8
Fixation screws and power connection

- Connect the grounding wire (PE wire) mounted on the LPS fixation into the socket of the LPS unit (2, image 19-8).
- Connect the mains input cables with the **MAINS INPUT** sockets of each LPS module as illustrated (3, image 19-8).
- Connect the power cables coming from the SPG module with the **LAMP OUT** sockets of the LPS module as illustrated. Fasten the nuts with a torque of **4Nm** (2.95 lbf*ft).

Warning: Make sure to place the washers and cable eyes in correct order upon the pin as illustrated. Always use a plain washer between the output pin and the cable eyes.

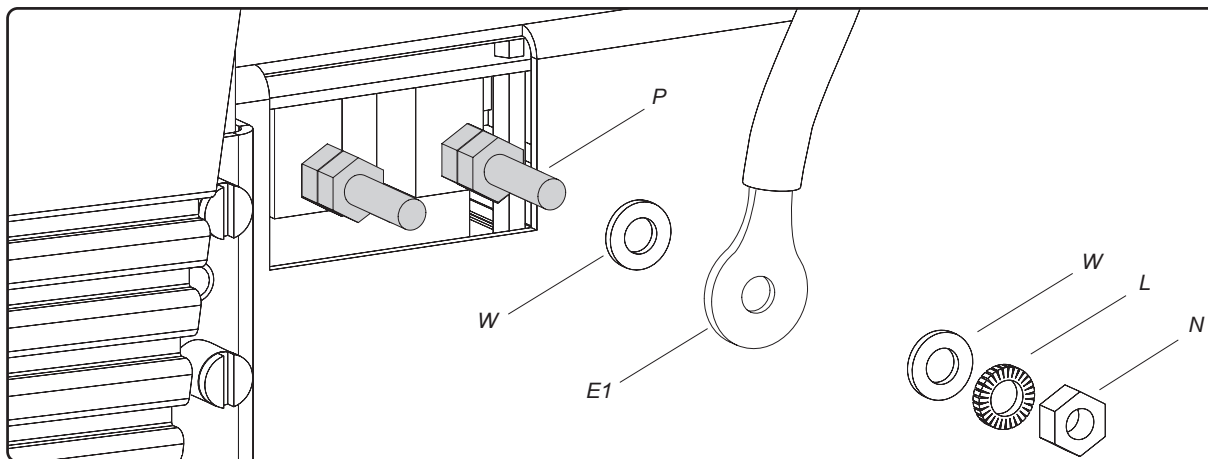

Image 19-9
Lamp out connection

- P LPS output pin.
- W Plain washer.
- L Lock washer.

19. Lamp power supply (single module)

E1 Cable eye from SPG module.
N Nut.

Warning: Respect the polarity of the socket and cables. Red marked cables with the “+” pin, black marked cables with the “-” pin.

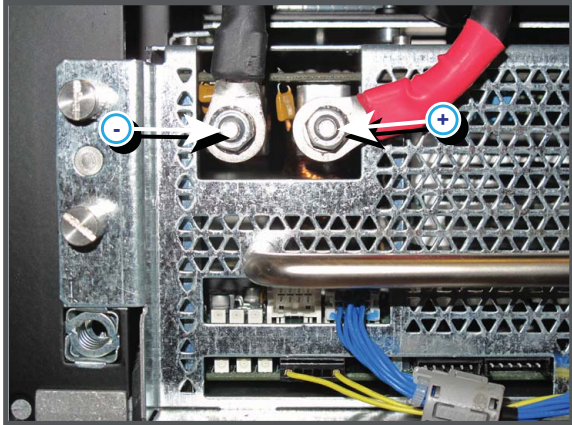

Image 19-10
High power connection, left

8. Connect the wire unit coming out of the projector with the **CTLB IN** socket of the LPS module (1).

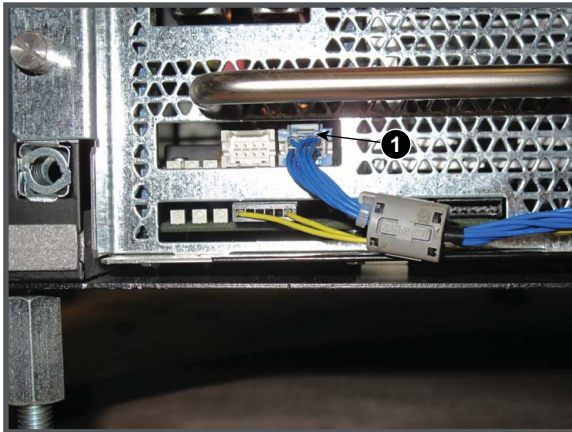

Image 19-11
Communication connections

19.4 Replacing a large frame LPS with a single module LPS

How to replace

1. Remove the large frame LPS module, "Removal of the LPS module", page 295.
2. Before inserting an LPS unit, place the positioning pin at the backside in its correct position.

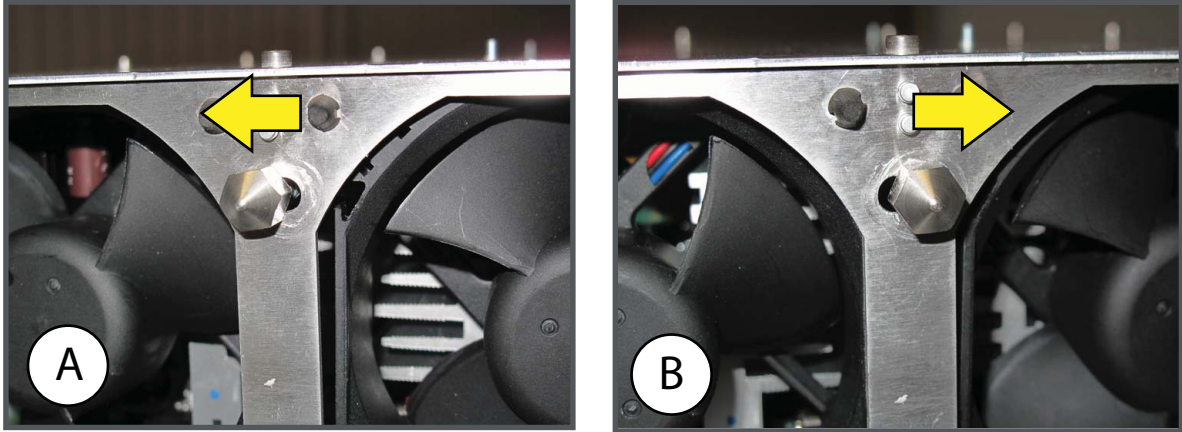

Image 19-12
Positioning pin

- A To be built-in in the left position (for DP2K-12C)
B To be built-in in the right position

For a LPS unit to be built-in at the left side of the LPS compartment (DP2K-12C), the positioning pin must be in the left position when seen from the backside of the unit.

To move the pin to the left or the right, pull on the pin and slide it to the left or to the right.

3. Slide a single LPS units n the compartment at the left side.

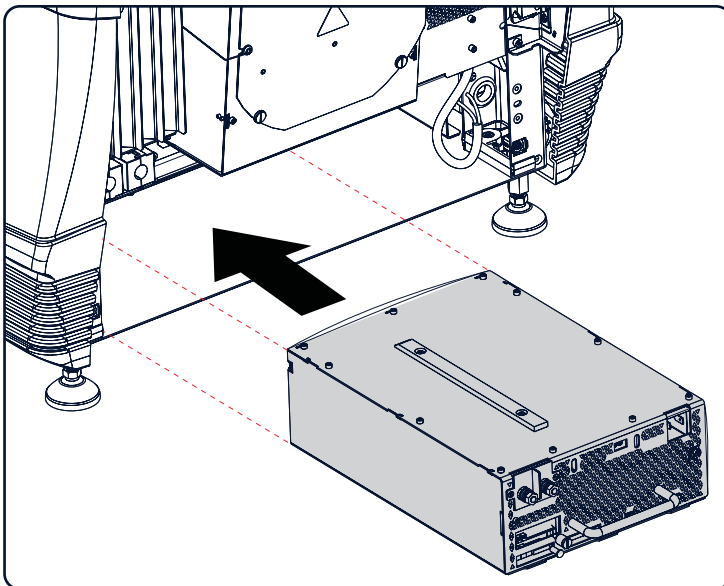

Image 19-13
Insert LPS unit

4. Slide the fixation frame on the front of the LPS unit in such a way that the fixation pins match the fixation holes.

19. Lamp power supply (single module)

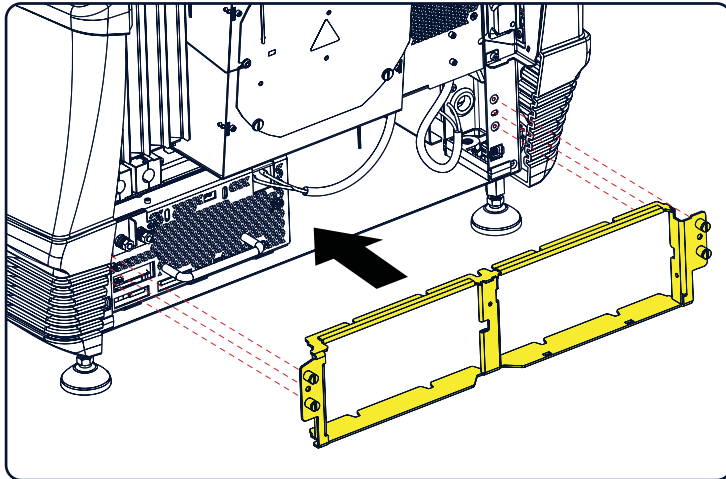

Image 19-14
Fixation frame

5. Secure the 4 spring screws (1).

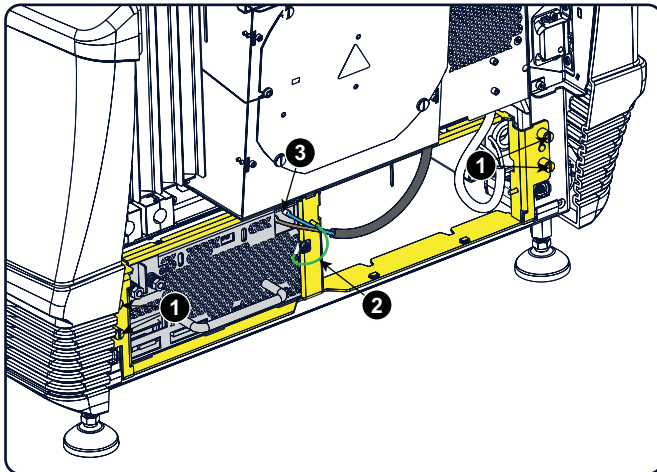

Image 19-15
Fixation screws

6. Connect the grounding wire (PE wire) mounted on the LPS fixation into the socket of the LPS unit (2).
7. Connect the mains input cables with the **MAINS INPUT** sockets of each LPS module as illustrated (3).
8. Connect the power cables coming from the SPG module with the **LAMP OUT** sockets of the LPS module as illustrated. Fasten the nuts with a torque of **4Nm** (2.95 lbf*ft).

Warning: Make sure to place the washers and cable eyes in correct order upon the pin as illustrated. Always use a plain washer between the output pin and the cable eyes.

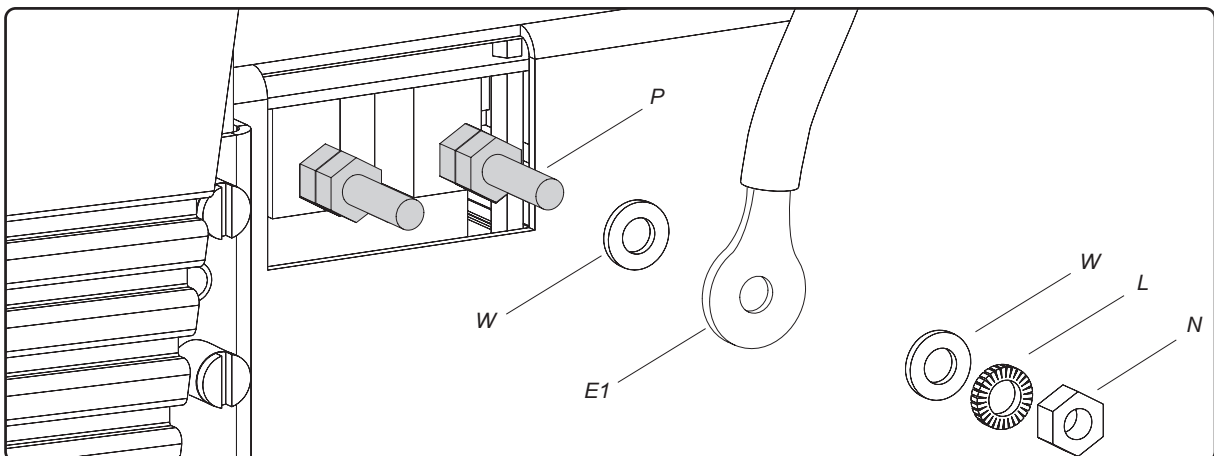

Image 19-16
Lamp out connection

- P LPS output pin.
W Plain washer.
L Lock washer.
N Nut.

- E1 Cable eye from SPG module.
- N Nut.

Warning: Respect the polarity of the socket and cables. Red marked cables with the “+” pin, black marked cables with the “-” pin.

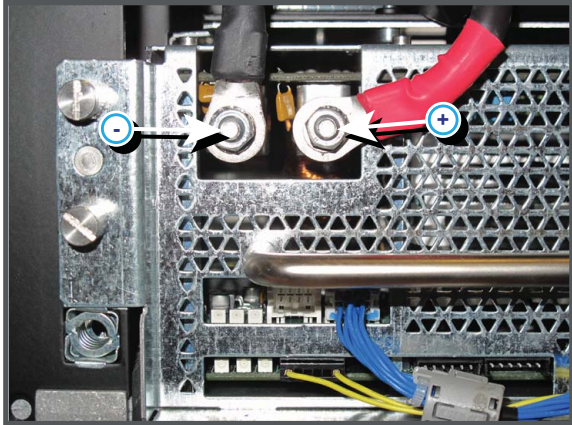

Image 19-17
High power connection, left

9. Connect the wire unit coming out of the projector with the **CTLB IN** socket of the left LPS unit (1).

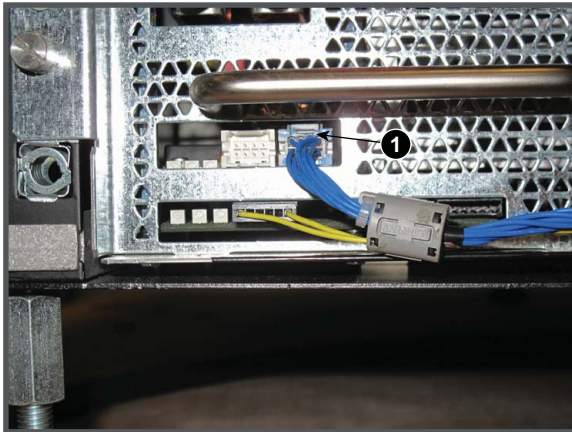

Image 19-18
Communication connections

20. START PULSE GENERATOR

About this chapter

This chapter describes briefly the functionality, the different parts and the replacement procedure of the Start Pulse Generator (SPG).

Overview

- Introduction
- Troubleshooting
- Removal of the Start Pulse Generator
- Installation of the Start Pulse Generator

20.1 Introduction

Functionality

The purpose of the Start Pulse Generator (SPG) is to ignite the lamp with a burst of high voltage peaks. The SPG superimposes high voltage peaks onto the normal dc start-up voltage of the lamp supplied by the Lamp Power Supply. Once the lamp is started up and illuminating, the high voltage is removed and the lamp voltage drops to the arc voltage. The high voltage peaks are added to the lamp voltage by a superimposing transformer which is in series with the positive connection from the LPS to the lamp. The negative connection from LPS to lamp is direct and is connected to the chassis at the lamp side. The full lamp current passes through the secondary of the superimposing transformer.

Parts

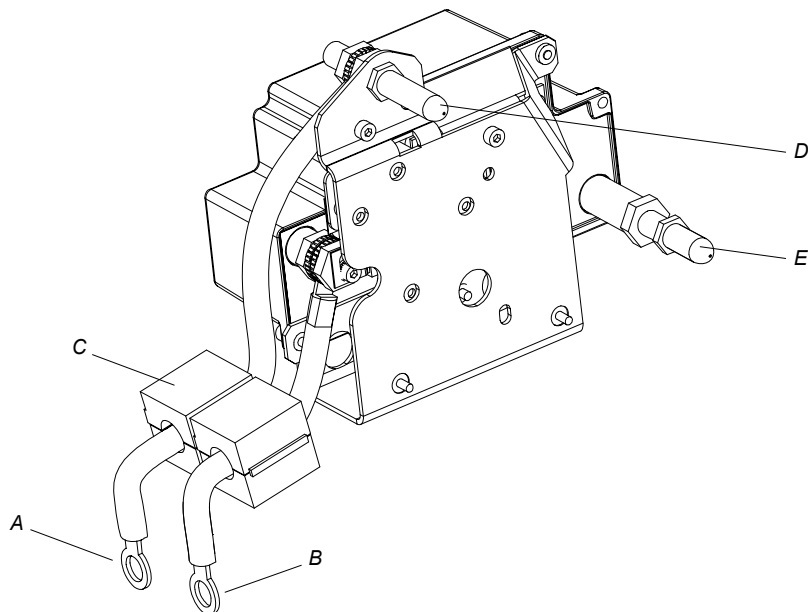

Image 20-1

- A Black marked cable lug. Has to be connected with the negative "LAMP OUT" pin of the LPS module.
- B Red marked cable lug. Has to be connected with the positive "LAMP OUT" pin of the LPS module.
- C Ferrite block.
- D Negative connection pin from SPG to lamp house.
- E Positive connection pin from SPG to lamp house.

20.2 Troubleshooting

Lamp fails to ignite after you switched the projector from standby to operation

| Situation | Solution |
|---|---|
| <p>You can hear the SPG module three times clicking in an attempt to ignite the lamp. The voltage on the "LAMP OUT" pins of the LPS module is first 140 volt during the attempt to ignite and then drops to 0 volt.</p> <p>Note: The ambient noise must be low to hear the SPG clicking in an attempt to ignite the lamp.</p> | <ul style="list-style-type: none"> • The LPS and SPG seem to work normally but the lamp is bad. Install another lamp house. • If the problem remains, replace the SPG module. |
| <p>You can not hear the SPG module three times clicking in an attempt to ignite the lamp. The voltage on the "LAMP OUT" pins of the LPS module is first 140 volt during the attempt to ignite and then drops to 0 volt.</p> <p>Note: The ambient noise must be low to hear the SPG clicking in an attempt to ignite the lamp.</p> | <ul style="list-style-type: none"> • Check the cabling of the SPG module. • Replace the SPG module. |
| <p>You can not hear the SPG module three times clicking in an attempt to ignite the lamp. The voltage on the "LAMP OUT" pins of the LPS module is below 140 volt during the attempt to ignite. The diagnostic LED's of the LPS module indicates a problem with the LPS module.</p> <p>Note: The ambient noise must be low to hear the SPG clicking in an attempt to ignite the lamp.</p> | <ul style="list-style-type: none"> • Check the cabling of the LPS module. • Replace the LPS module. |

20.3 Removal of the Start Pulse Generator



To remove or install the start pulse generator you have to remove the side cover, the back cover, the lamp cover and the lamp house first. This procedure assumes that these covers are already removed.

Necessary tools

- 10 mm nut driver.
- 3 mm Allen wrench.
- 6 x 120 mm flat screw driver.

How to remove the Start Pulse Generator

1. Disconnect the SPG cables from the "LAMP OUT" pins of the LPS module. Use a 10 mm nut driver.

Caution: Do not lose the washers which fit between the fixation nuts and the cable eye.

Tip: Place the washers and nuts back upon the output pins.

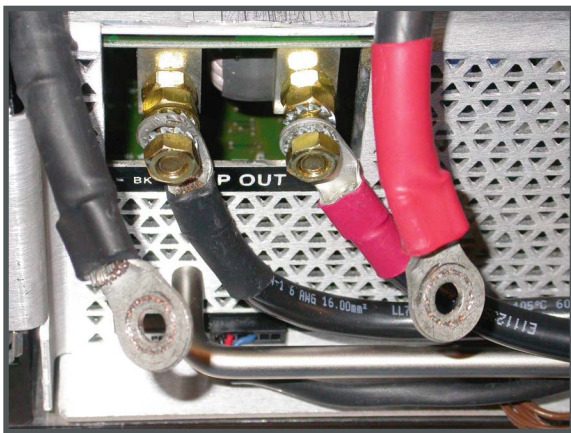

Image 20-2
Disconnect SPG cables

2. Remove the cover of the Start Pulse Generator as illustrated. This cover is secured with 5 hexagon socket head cap screws. Use a 3 mm Allen wrench.

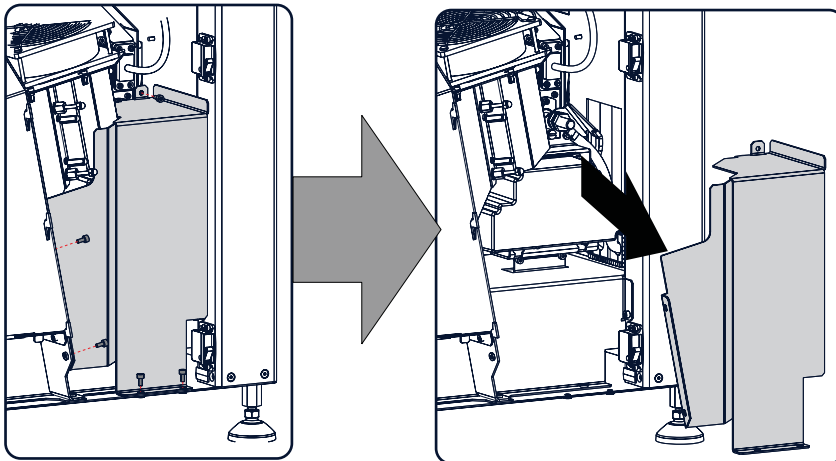

Image 20-3
Remove SPG cover

3. Release the 3 captive screws (S) of the Start Pulse Generator as illustrated. Use a flat screw driver.

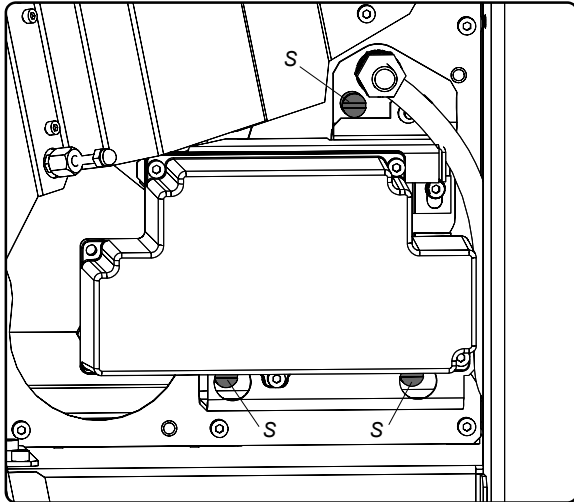

Image 20-4
Loosen SPG fixation

4. Remove the Start Pulse Generator from the projector.

Caution: Do not damage the ferrite blocks while removing the SPG module.

Note: The ferrite blocks have to be reused upon the SPG module which you want to install.

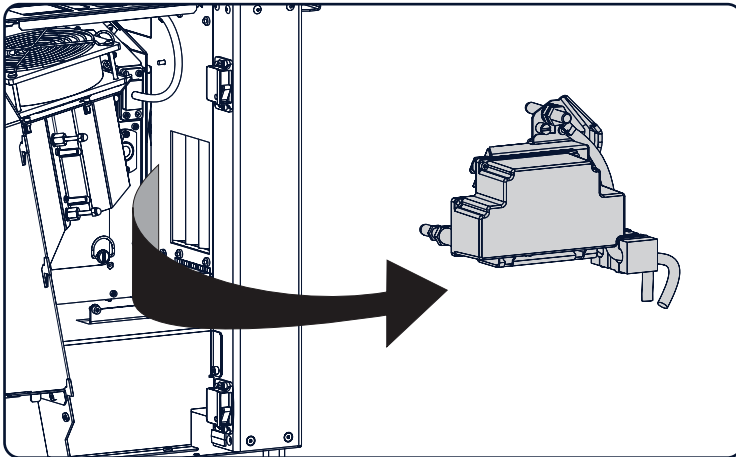

Image 20-5
Remove SPG

20.4 Installation of the Start Pulse Generator



Make sure that lamp house is removed !

Necessary tools

- Torque wrench with a 10 mm hexagon socket.
- 3 mm Allen wrench.
- 6 x 120 mm flat screw driver.

How to install the Start Pulse Generator

1. Insert the Start Pulse Generator in the projector. Guide the wires gently through the frame opening.
Caution: Make sure not to damage the wires.

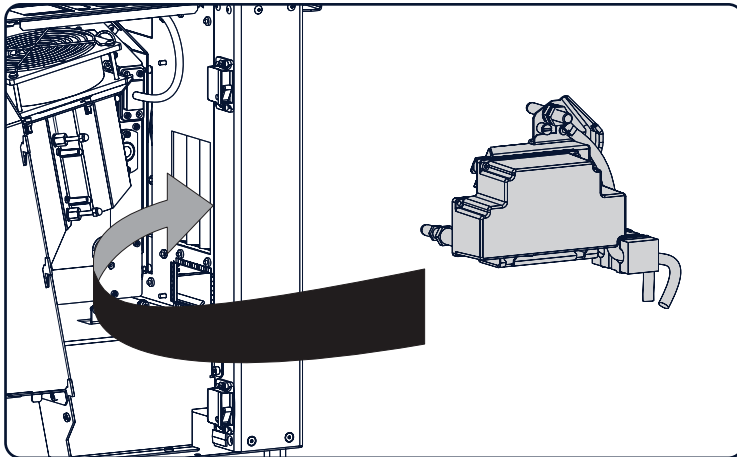

Image 20-6
Insert SPG

2. Fasten the 3 captive screws (S) of the Start Pulse Generator as illustrated, using a flat screw driver.

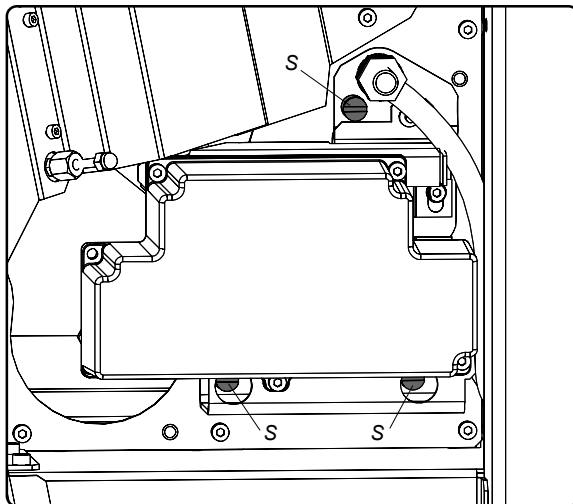

Image 20-7
Fixate SPG

3. Install the cover of the Start Pulse Generator as illustrated. The cover has to be fasten with 5 hexagon socket head cap screws. Use for that a 3 mm Allen wrench.

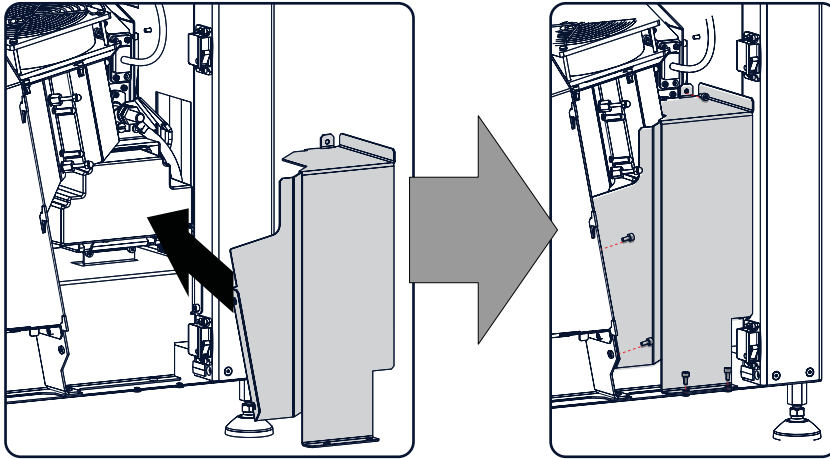

Image 20-8

4. Connect the power cables coming from the Start Pulse Generator with the "LAMP OUT" sockets of the LPS module as illustrated. Fasten the nuts with a torque of **4Nm** (2.95 lbf*ft).

Warning: Make sure to place the washers and cable eyes in correct order upon the pin as illustrated. Always use a plain washer between the output pin and the cable eyes.

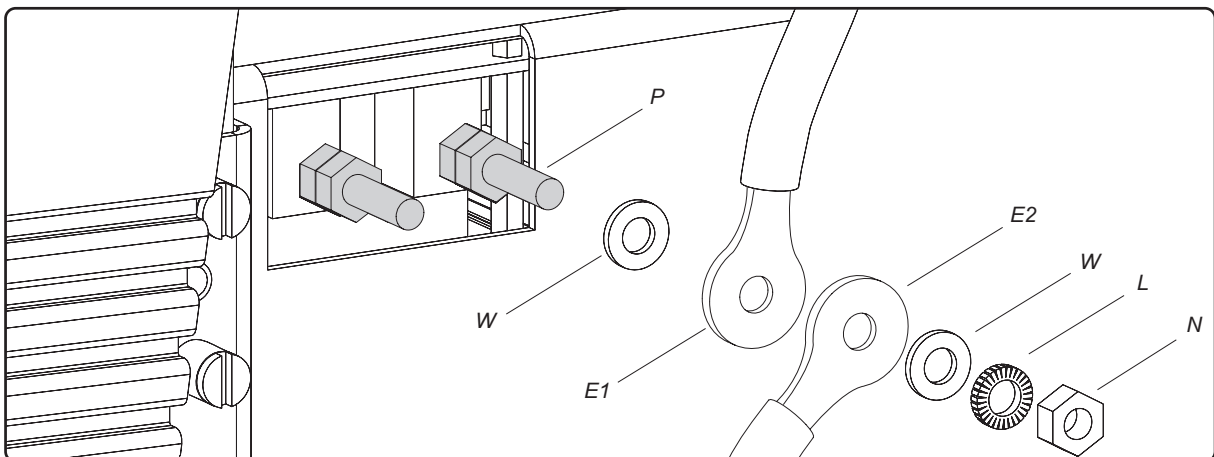

Image 20-9
Lamp out connection

- P LPS output pin.
- W Plain washer.
- L Lock washer.
- E1 Cable eye from SPG module.
- E2 Cable eye from LPS unit.
- N Nut.

Warning: Respect the polarity of the socket and cables. Red marked cables with the "+" pin, black marked cables with the "-" pin.

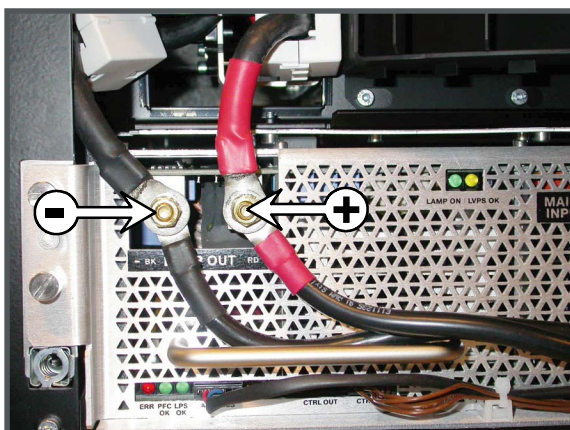

Image 20-10

Warning: Make sure that both SPG cables are provided with ferrite blocks (C). Reuse the ferrite blocks of the removed SPG module in case no ferrite blocks are present upon the installed SPG module.

20. Start Pulse Generator

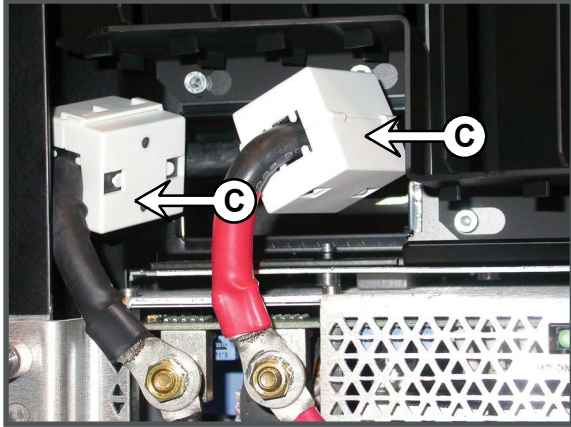

Image 20-11

5. Reinstall the lamp house and the covers of the projector.

21. FAN REPLACEMENT PROCEDURE

Overview

- Card cage fans
- SMPS compartment fans
- Light processor compartment fan
- Lamp cathode fan
- Lamp anode fan
- Cold mirror fan
- Lamp Info Module fan
- Integrated cinema processor fan

21.1 Card cage fans

Necessary tools

Allen key 3 mm

How to replace

1. Remove the front cover, "Removal of the front cover", page 80.
2. Remove the front filter as follows:
 - a) Remove the input cover, "Removal of the input cover", page 79.
 - b) Pull the small handle a little backwards and then to the front of the projector until the filter frame is released.
 - c) Slide out the filter.
3. Disconnect the fan power cable(s). If necessary, cut the cable tie.

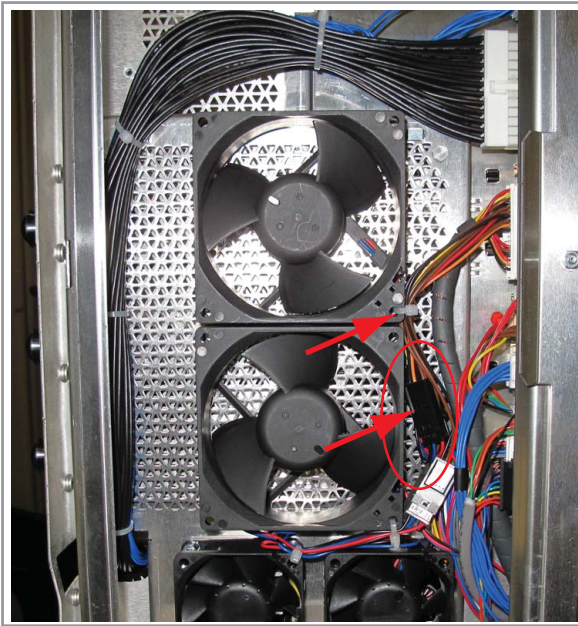

Image 21-1
Card cage fans, connection

4. Turn out the 4 fixation screws. Use the front holes in the fan housing to reach these screws.

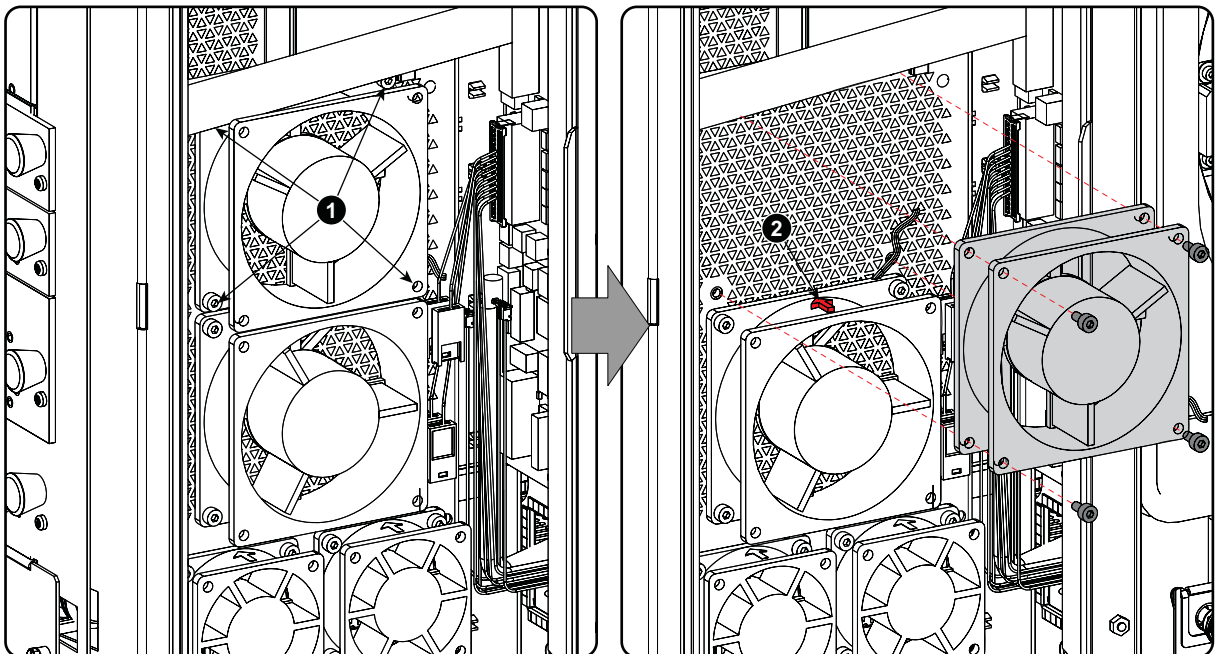

Image 21-2
Card cage fans, removal

5. Take out the fan.
6. Insert a new fan, with the arrow indication on the fan pointing to the inner side of the projector.
7. Drive in the 4 fixation screws.
8. Reconnect the fan power cable. Use a cable tie to secure the cables.

21.2 SMPS compartment fans

Necessary tools

Allen key 3 mm

How to replace

1. Remove the front cover, "Removal of the front cover", page 80.
2. Remove the front filter as follow :
 - a) Remove the input cover, "Removal of the input cover", page 79.
 - b) Pull the small handle a little backwards and then to the front of the projector until the filter frame is released.
 - c) Slide out the filter.
3. Disconnect the power cable of the defective fan. If necessary, cut the cable tie(s).

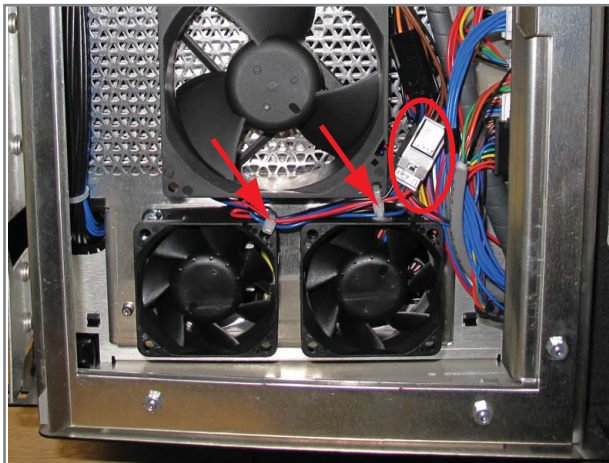

Image 21-3
SMPS fans, connection

4. Turn out the 4 fixation screws (1). Use the front holes in the fan housing to reach these screws.

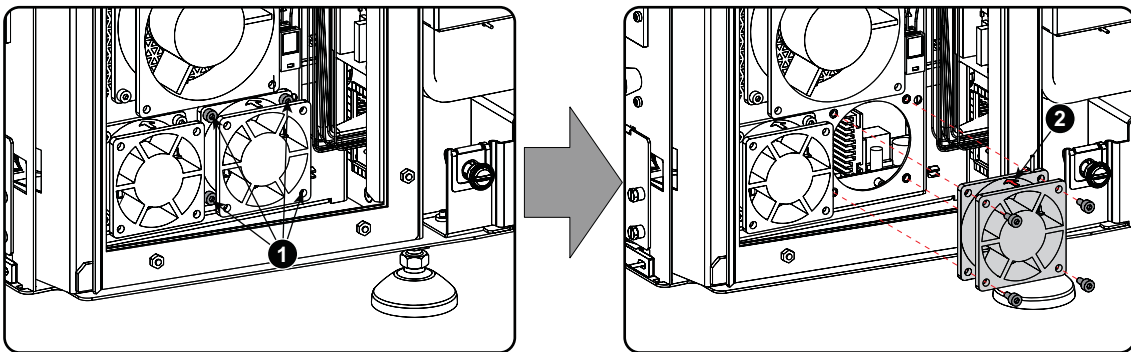

Image 21-4
Remove the SMPS compartment fan(s)

5. Take out the fan.

6. Insert a new fan, with the arrow indication on the fan pointing to the inner side of the projector (2).

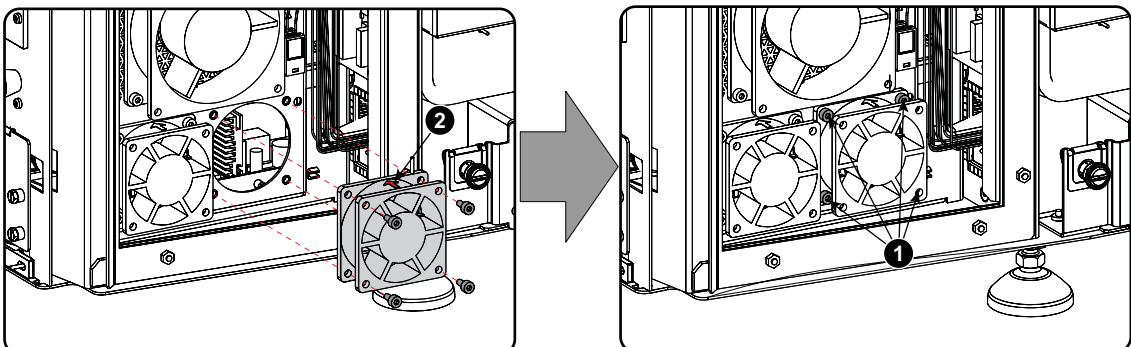

Image 21-5
Mount the SMPS compartment fan(s)

7. Drive in the 4 fixation screws.
8. Reconnect the fan power cable. Use a cable tie to secure the cables.

21.3 Light processor compartment fan

Necessary tools

Allen key 3mm

How to replace

1. Remove covers, see Removal and Installation of projector covers.
2. Remove the light processor cover.
3. Disconnect the fan power cable from the signal backplane.

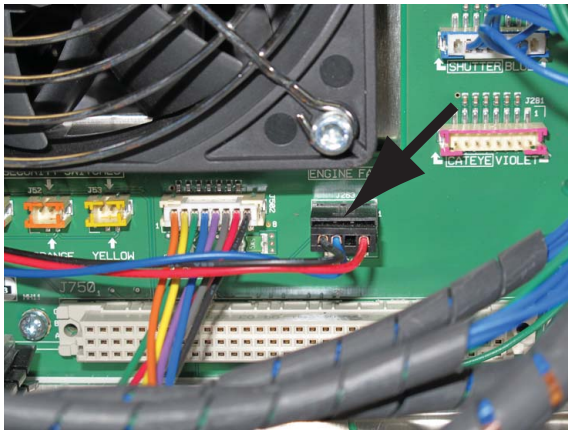

Image 21-6
Light processor fan connection

4. Remove the 4 screws.

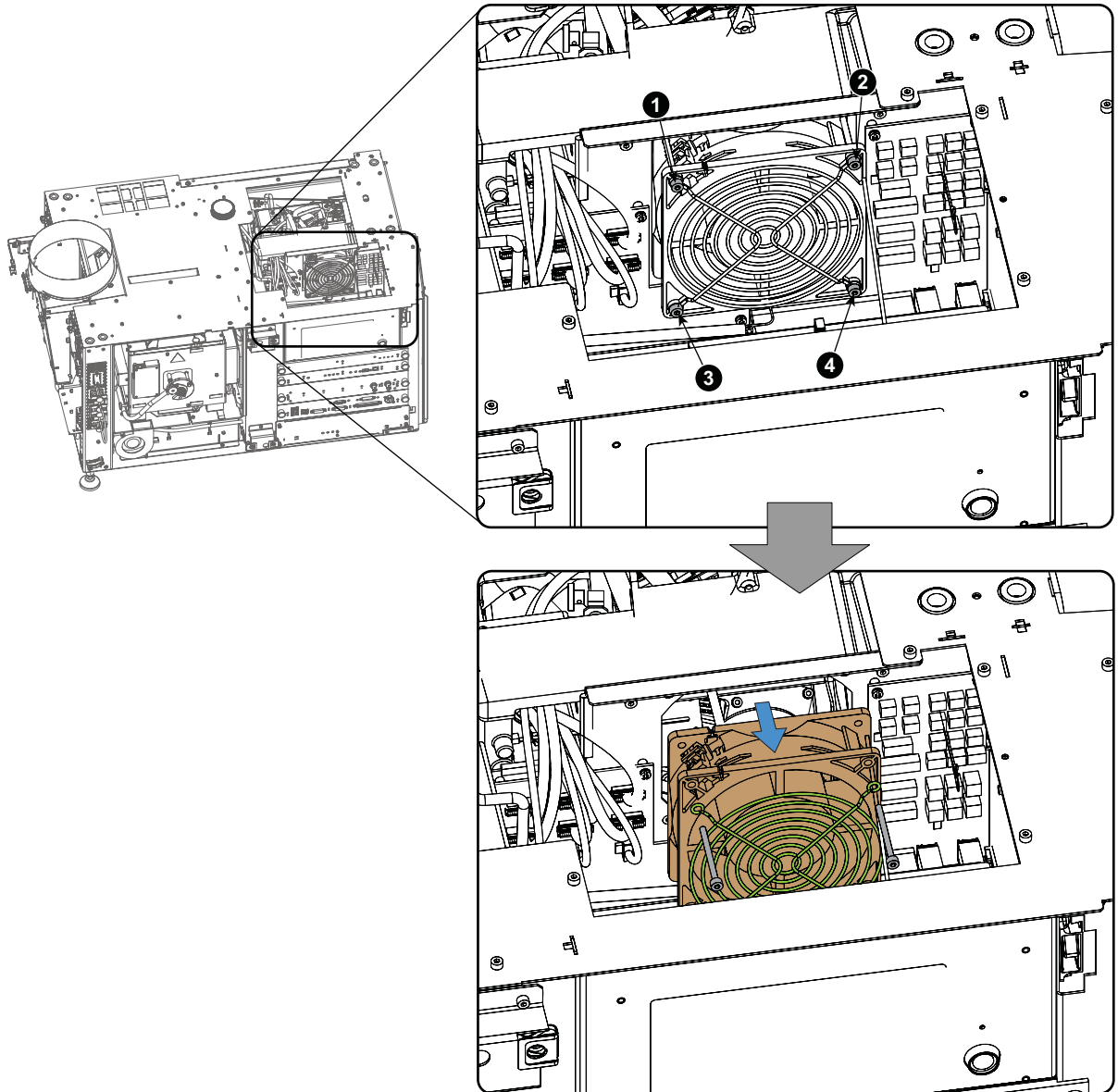

Image 21-7
Light compartment fan, removal

5. Take of the fan protection grid and the fan.
6. Insert a new fan with the arrow indication on the fan pointing towards the light processor.
Place the grid on the fan.

21. Fan replacement procedure

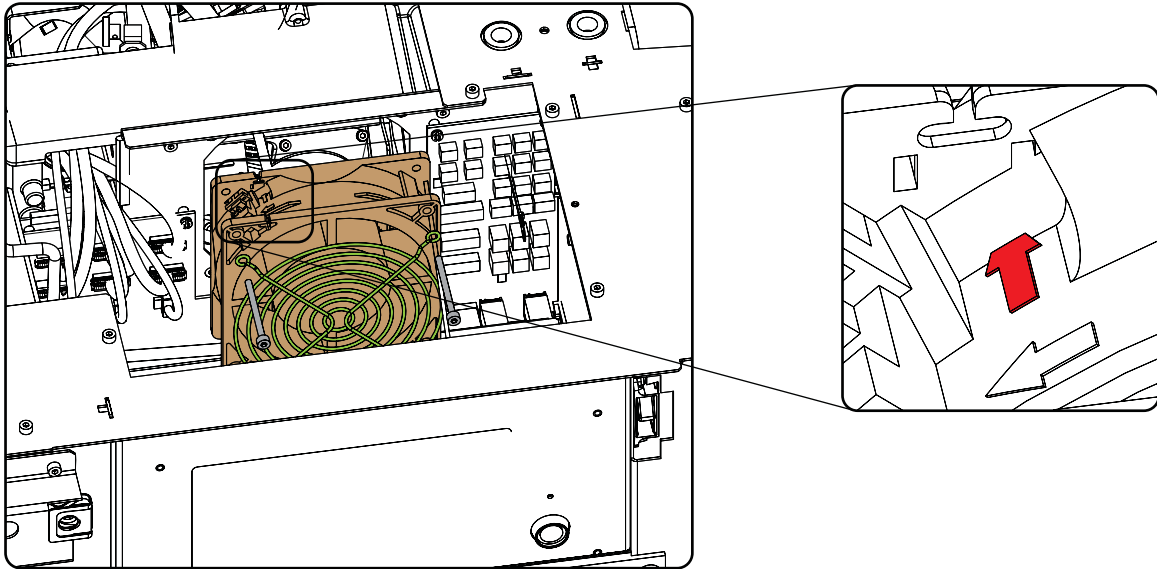

Image 21-8
Light compartment fan, mount

7. Drive in the 4 screws.

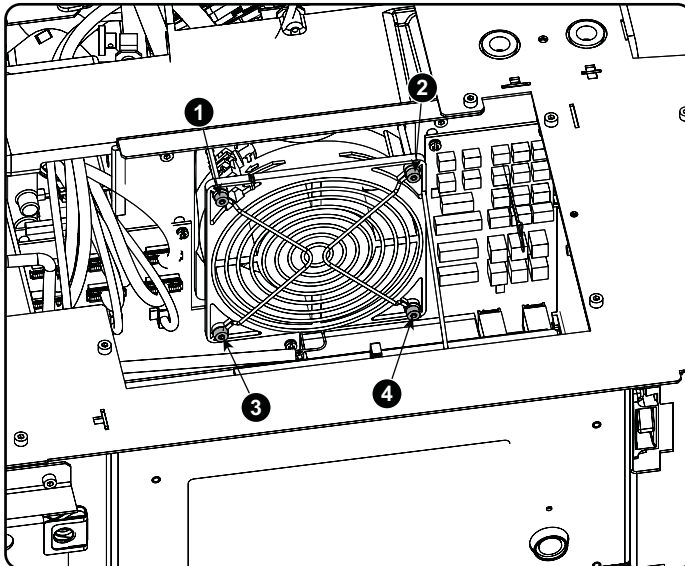

Image 21-9
Light compartment fan, screws

8. Connect the power cable to the signal backplane (image 21-6).
9. Reinstall the Light processor top cover.
Mount the housing, see Removal and Installation of the projector covers..

21.4 Lamp cathode fan



To access the cathode fan, the lamp house has to be removed. This procedure assumes that the lamp cover and lamp house are already removed.

Preparations

1. Remove the lamp cover.
2. Remove the lamp house.

Necessary tools

- 3 mm Allen wrench.
- 7 mm flat screwdriver.
- 7 mm nut driver.

How to replace

1. Remove the left side panel of the lamp compartment by removing the six indicated screws (reference 1).

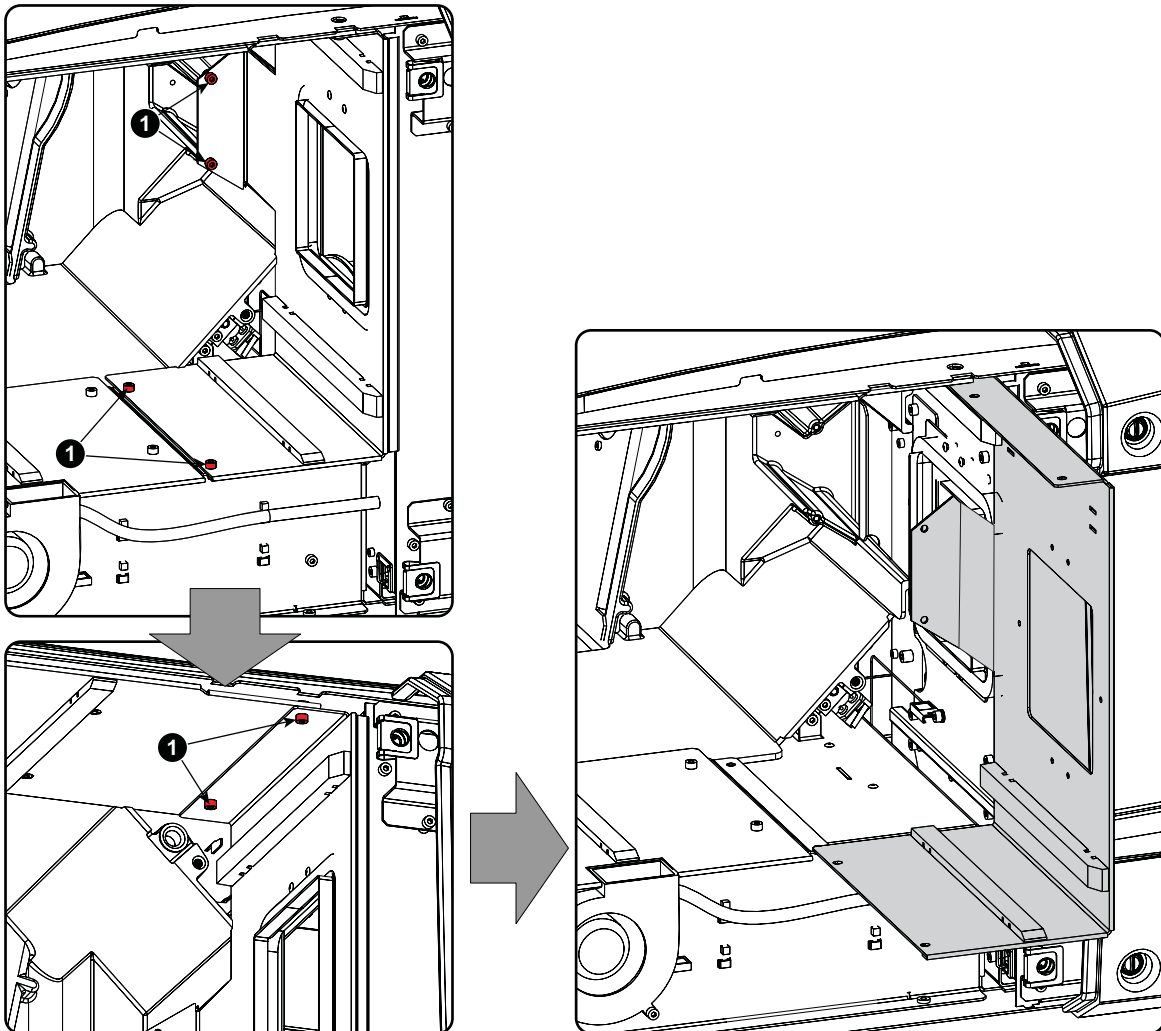

Image 21-10
Side panel lamp house, removal

2. Pull out the wire unit with connector from behind the plate and disconnect the power cable of the cathode fan.

21. Fan replacement procedure

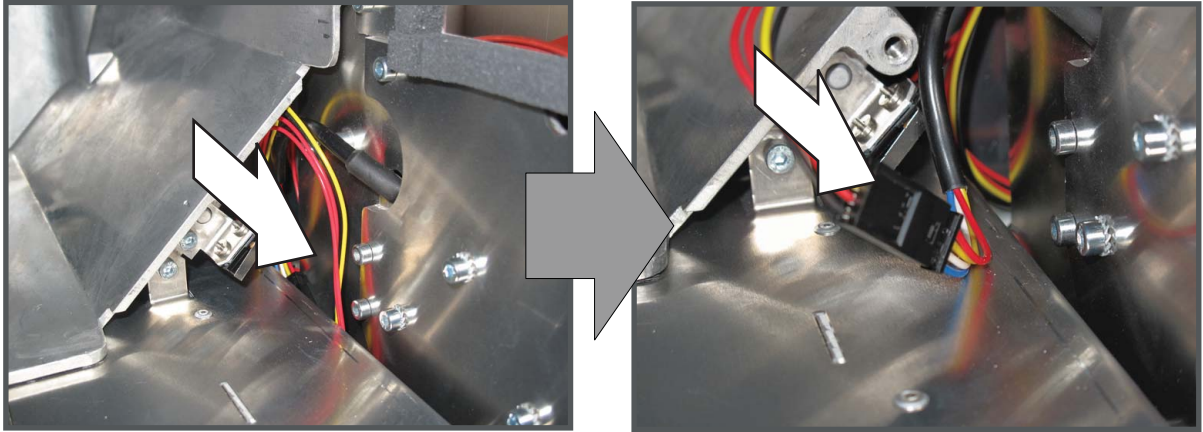

Image 21-11
Cathode fan, power disconnection

3. Remove the small side plate of the air channel by releasing the three screws (reference 2). Cut the foam rubber (reference 3) as it is stuck on different plates.

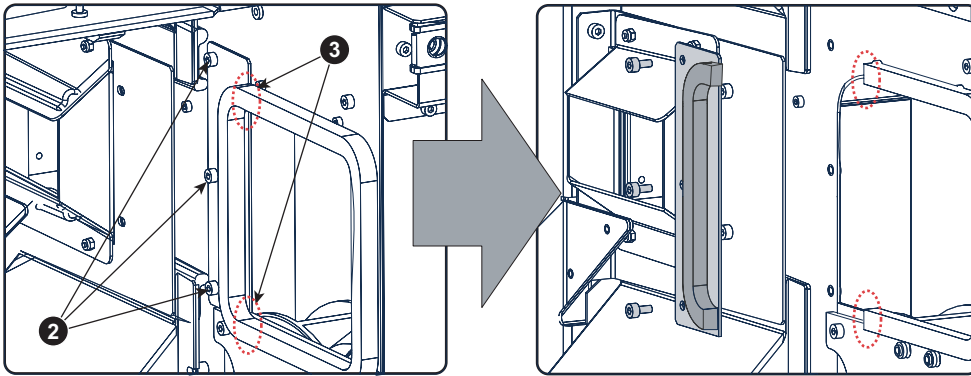

Image 21-12
Small side plate, removal

4. Remove the cathode fan assembly out of its compartment by releasing the five indicated screws (reference 4). Cut the foam rubber (reference 5) as it is stuck on different plates.
Tip: Lift up and slightly turn the fan assembly to remove.

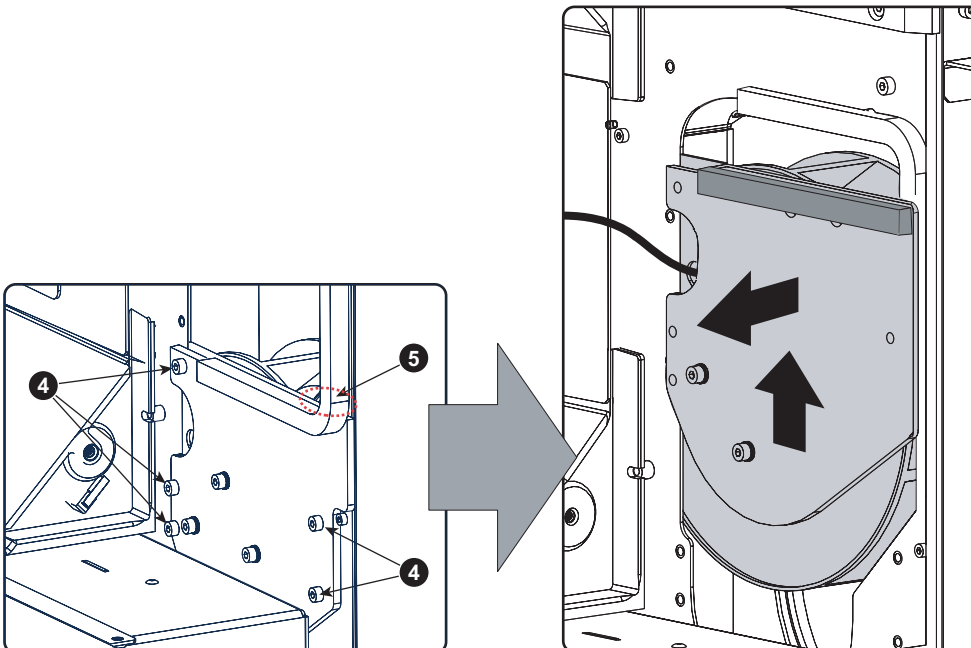

Image 21-13
Cathode fan assembly removal

5. Disassemble the cathode fan assembly by removing the five indicated screws (reference 6).

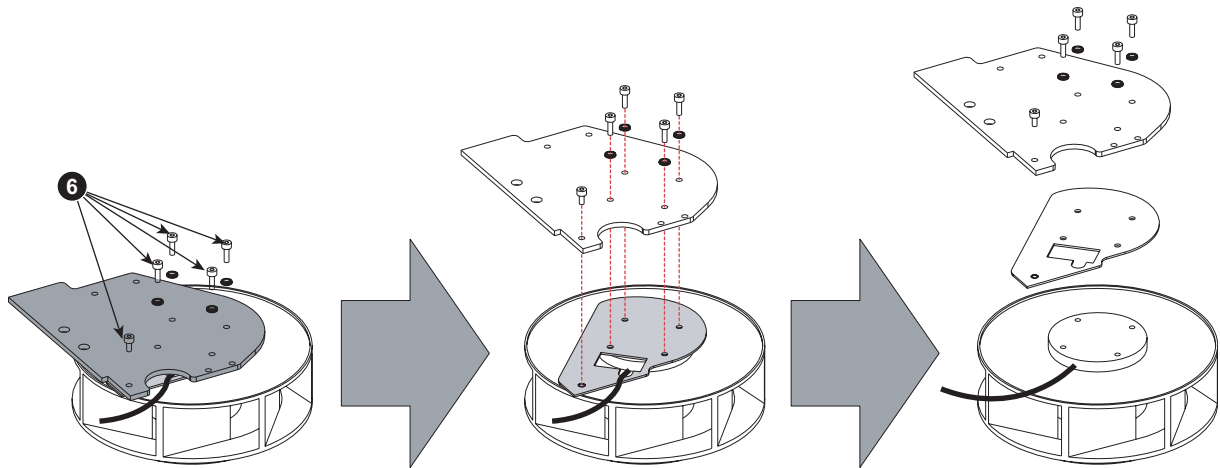

Image 21-14
Cathode fan disassembling unit

6. Fasten the two plates upon the new cathode fan with five screws (reference 6). Provide the four screws in the center with a washer (reference 7). Note that the wire unit of the fan must be guided through the hole of the lower plate.

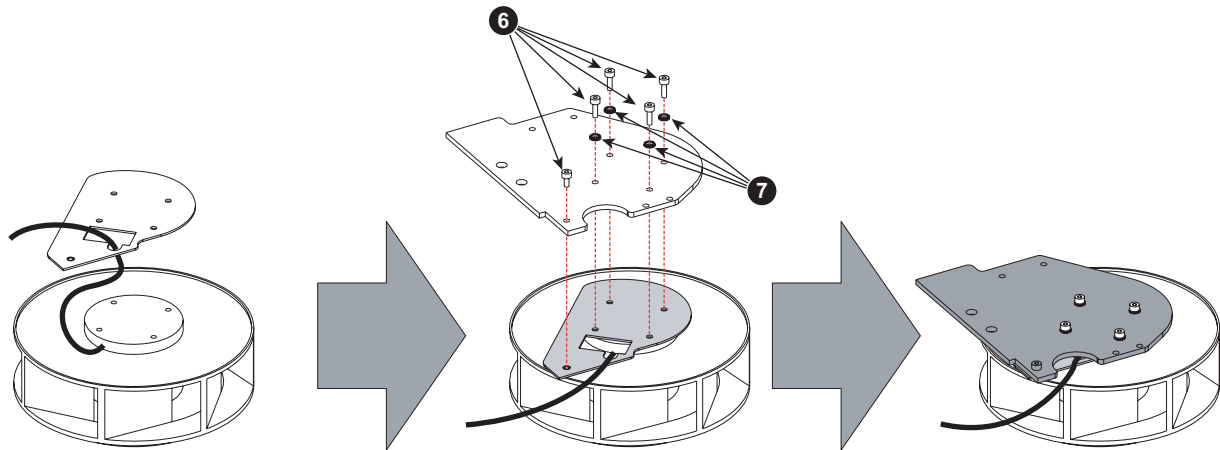

Image 21-15
Assembling the unit

7. Install the fan assembly back in its compartment with five screws (reference 8). Use a 3 mm Allen wrench.
Caution: Make sure that the wire unit of the fan does not get jammed.

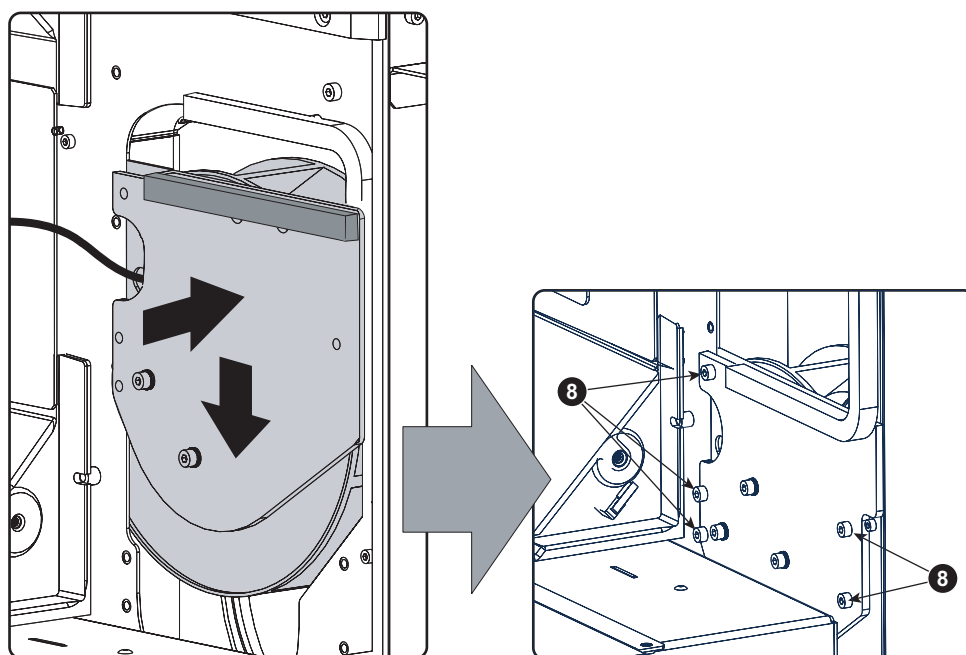

Image 21-16
Cathode fan assembly, mounting

21. Fan replacement procedure

8. Install the small side plate of the air channel with three screws (reference 9).

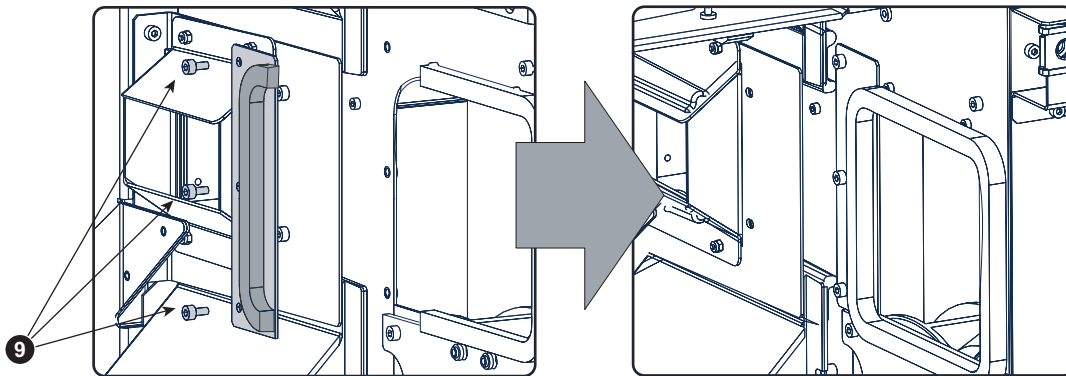

Image 21-17
Small side plate, mounting

9. Reconnect the wire unit of the cathode fan and hide the connector behind the plate.

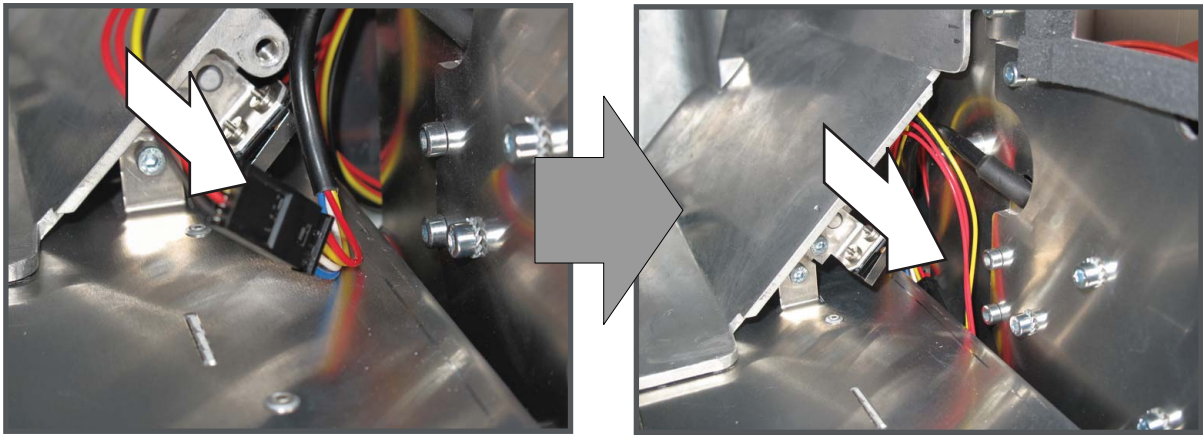

Image 21-18
Cathode fan, power connection

10. Reinstall the left side panel of the lamp compartment with six screws (reference 10).

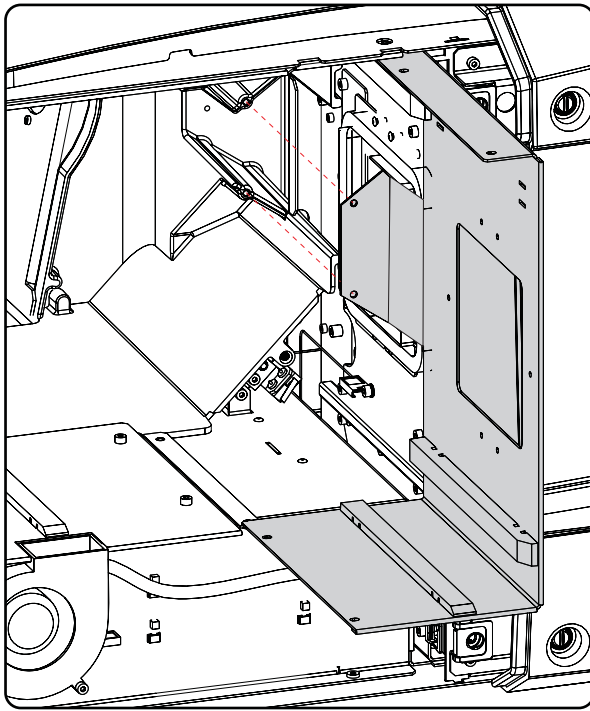
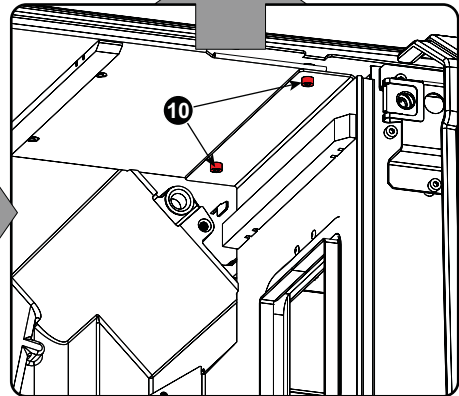
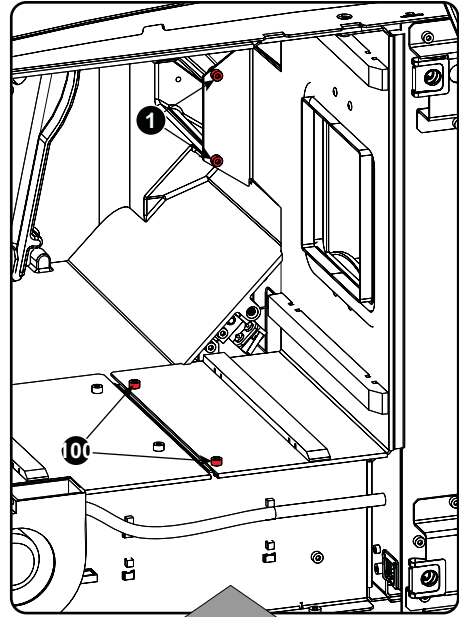

Image 21-19
Side panel lamp house, installation



21.5 Lamp anode fan



To access the anode fan, the light processor has to be removed. This procedure assumes that the light processor is already removed.

Necessary tools

- 2,5 mm Allen wrench.
- 3 mm Allen wrench.
- 5 mm Allen wrench.
- Pair of pliers.
- Universal pliers.
- 7 mm open-end wrench.

How to replace

1. Disconnect the anode fan (reference 1).

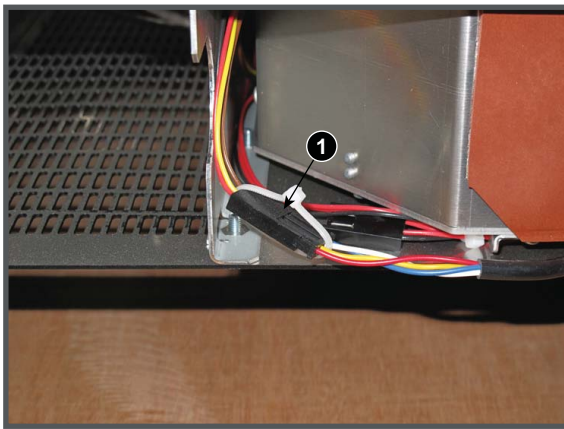

Image 21-20
Anode fan connection

2. Remove the anode fan security guard and fan bezel by releasing the four hexagon socket head cap screws (reference 1). Use a 3 mm Allen wrench.

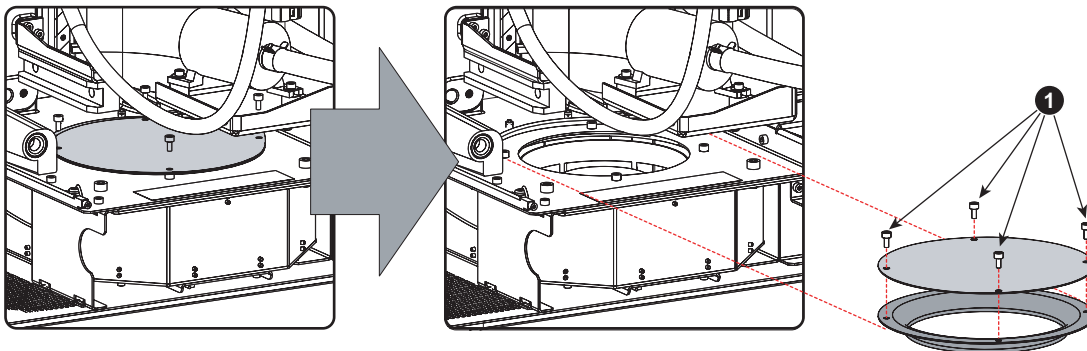

Image 21-21
Remove fan security guard

3. Release the three indicated hexagon socket head cap screws (reference 2) and slide out the anode fan assembly. Use a 5 mm Allen wrench.

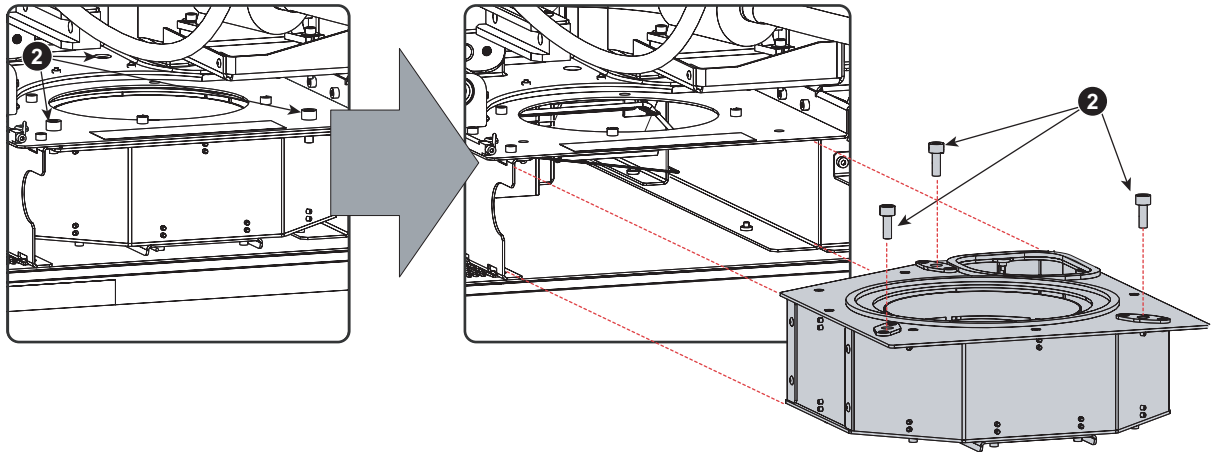

Image 21-22
Remove fan assembly

4. Remove the fan from the fan house by releasing first the 11 small screws at the edge (reference 3) and then the 4 big screws in the middle (reference 4) as illustrated. Use a 2,5 mm and a 3 mm Allen wrench.

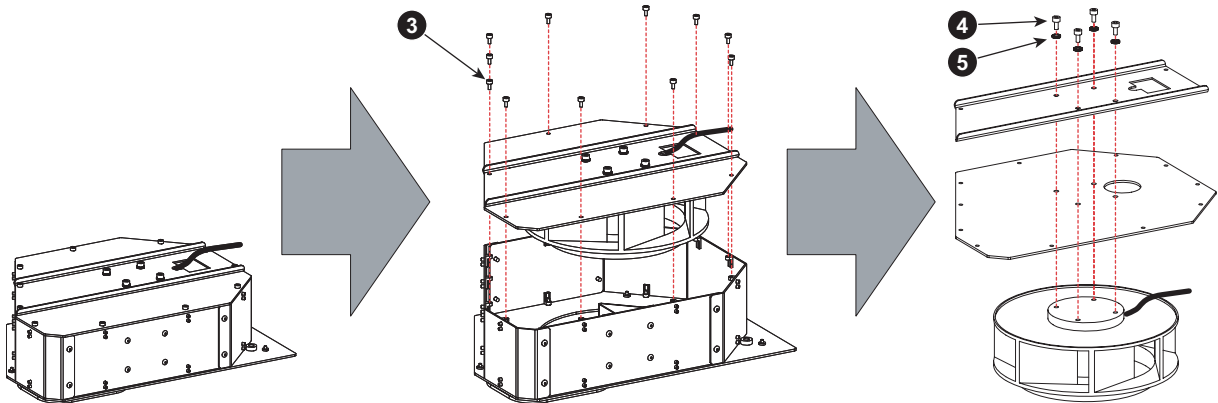

Image 21-23
Remove fan

5. Install a new anode fan inside the fan house as follows:
- Guide the wire unit of the anode fan through the holes in mounting plates.
 - Fasten the two mounting plates upon the fan with four hexagon socket head cap screws (reference 6) as illustrated. Provide each screw with a washer (reference 7).
 - Close the anode fan house with 11 screws (reference 8).

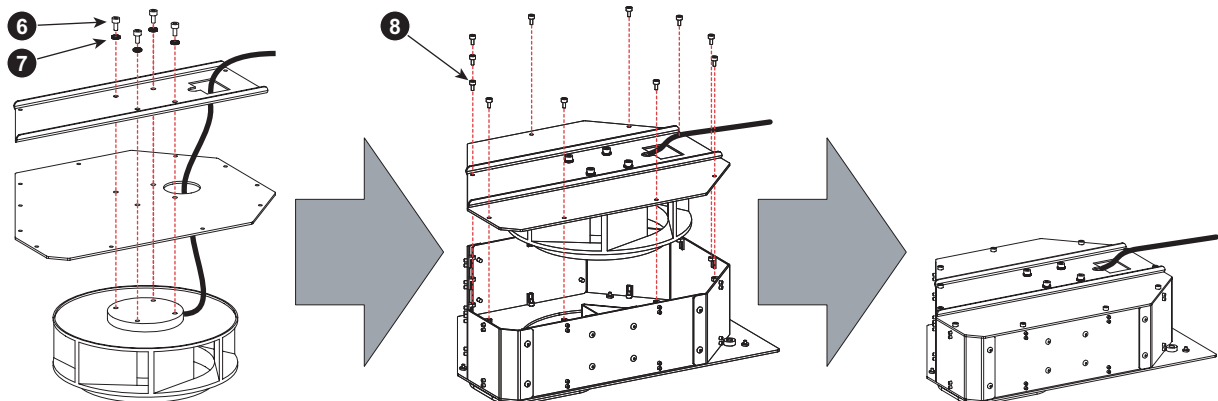

Image 21-24
Mount fan

6. Slide the anode fan assembly back in its compartment and secure with 3 big hexagon screws (reference 9). Use a 5 mm Allen wrench.

21. Fan replacement procedure

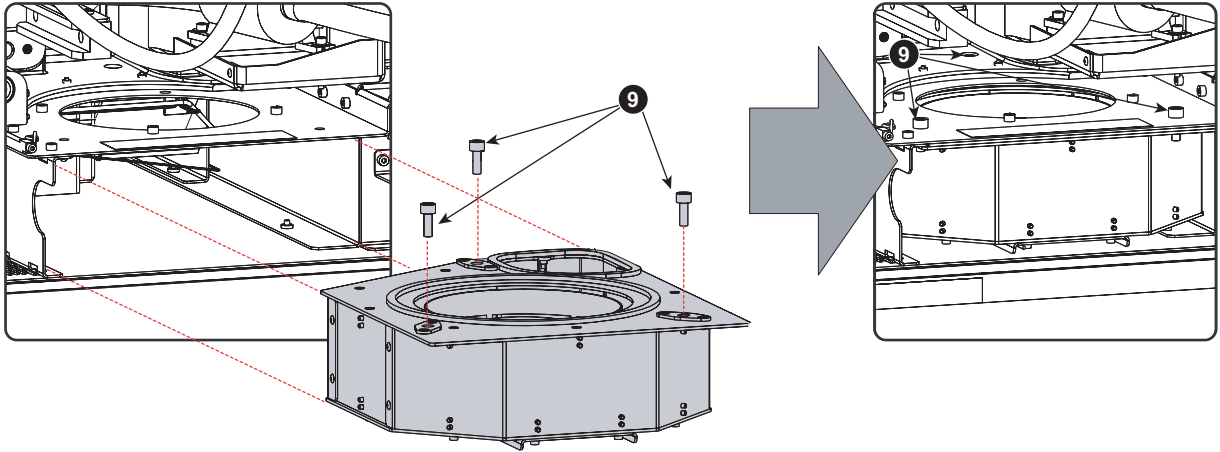

Image 21-25
Insert fan assembly

7. Reinstall the anode fan bezel and security guard. Use a 3 mm Allen wrench to secure the four hexagon socket head cap screws (reference 10).

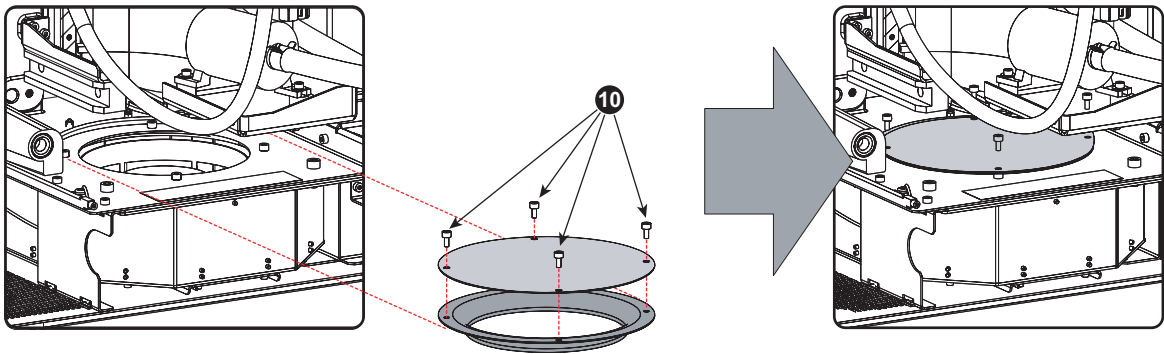

Image 21-26
Mount fan security guard

8. Reconnect the wire unit of the anode fan (reference 1 on image 21-20).

21.6 Cold mirror fan

Preparations

1. Remove the covers to get access to the cold mirror fan.
2. Remove the cover plat of the sealed compartment.

How to replace

1. Remove the cover of the Start Pulse Generator as illustrated. This cover is secured with 5 hexagon socket head cap screws. Use a 3 mm Allen wrench.

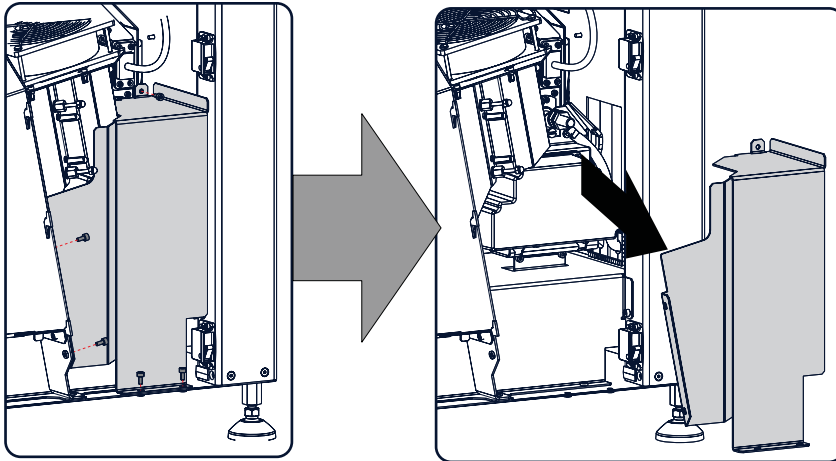

Image 21-27
Remove SPG cover

2. Disconnect the fan wire (reference 1).

Tip: Pull out the top filter for easy access to the fan wire connection.

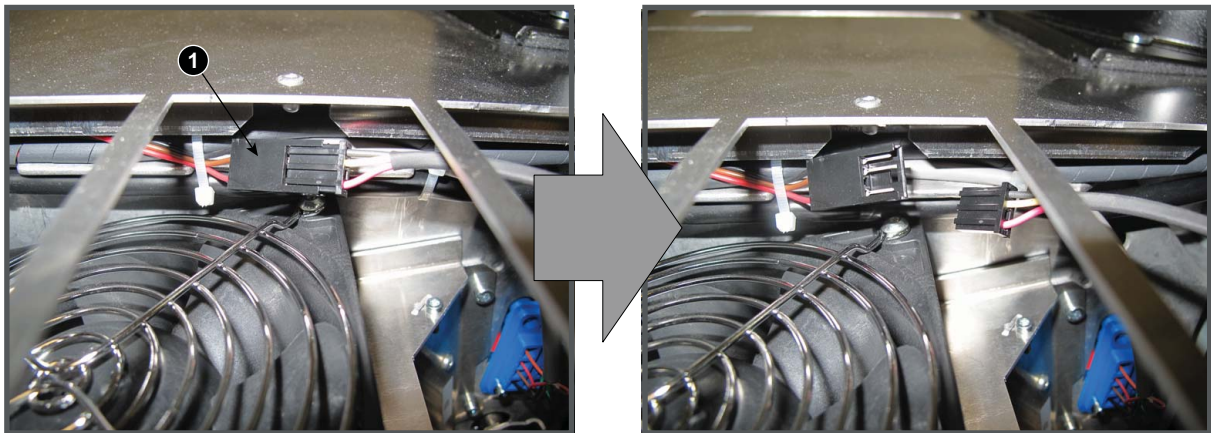

Image 21-28
Electrical disconnection

3. Turn out the 2 hexagon socket head cap screws at the right side (reference 2).

21. Fan replacement procedure

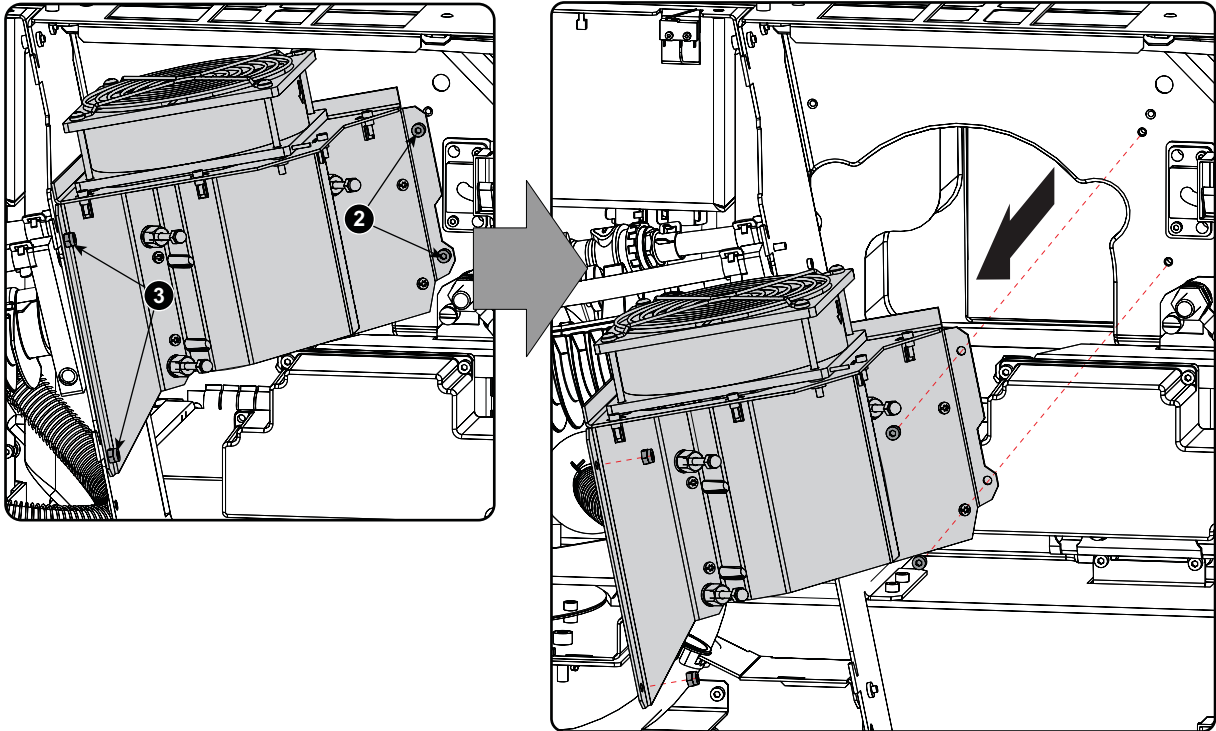

Image 21-29
Remove cold mirror

4. Remove both nuts at the left side (reference 3).
Support the assembly while removing the nuts.
5. Slide out the cold mirror assembly.
6. Turn out the 4 fixation screws (reference 1).
Take off the fan protection grid (reference 2) and remove the fan (reference 3).

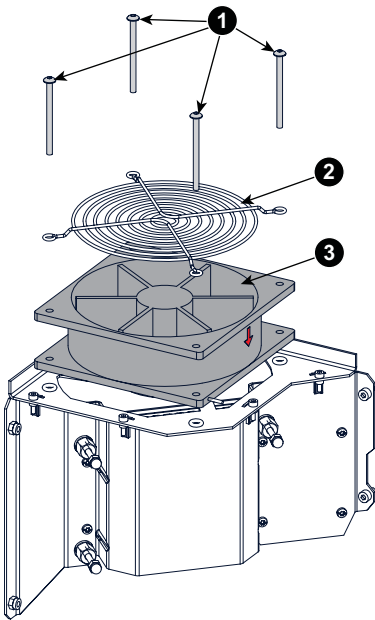

Image 21-30

7. Place new fan on the assembly with the arrow pointing to downwards.
8. Place the protection grid on the fan and drive in the 4 fixation screws.
9. Re-install the cold mirror assembly.

21.7 Lamp Info Module fan



To access the Lamp Info Module fan the lamp cover has to be removed. This procedure assumes that the lamp cover is already removed.

Necessary tools

3 mm Allen wrench.

How to replace the fan of the Lamp Info module?

1. Disconnect the wire unit (reference C) of the fan (reference FL).

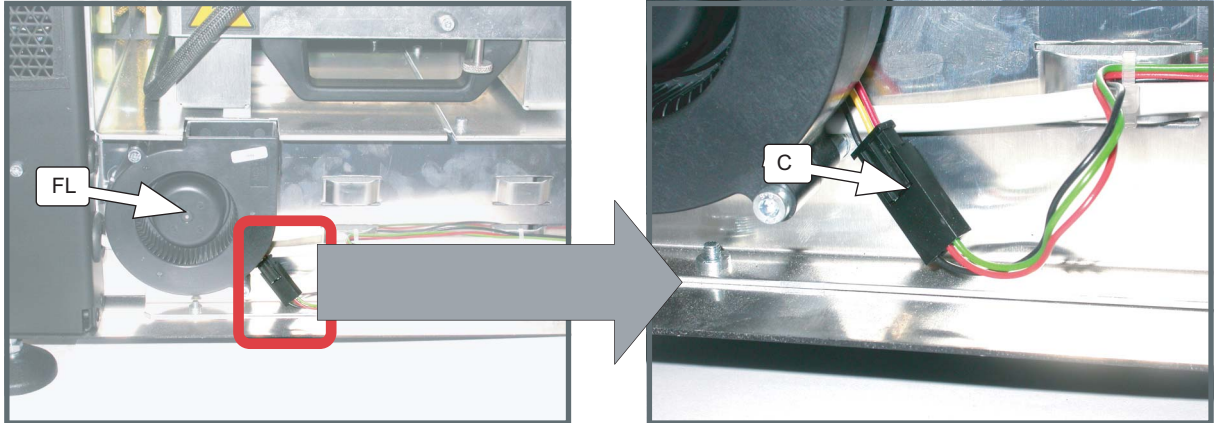

Image 21-31

2. Remove the fan from the projector by releasing the two hexagon socket head cap screws (reference 1). Use a 3 mm Allen wrench.

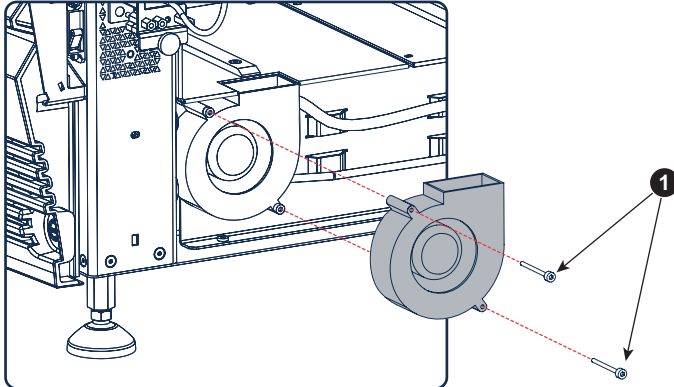

Image 21-32

3. Install a new fan as illustrated in image 21-32. Use a 3 mm Allen wrench to fasten the two hexagon socket head cap screws.
4. Reconnect the wire unit of the fan.

21.8 Integrated cinema processor fan

Preparations

First remove the following parts to get access to the fan.

1. Input cover and top cover, see Removal and Installation of the projector covers.
2. Remove the fan controller board, see "Removing a board in the card cage", page 221.
3. Remove the button unit, see "Removing the button unit", page 227.

How to replace

1. Disconnect the fan power cable from the backplane.

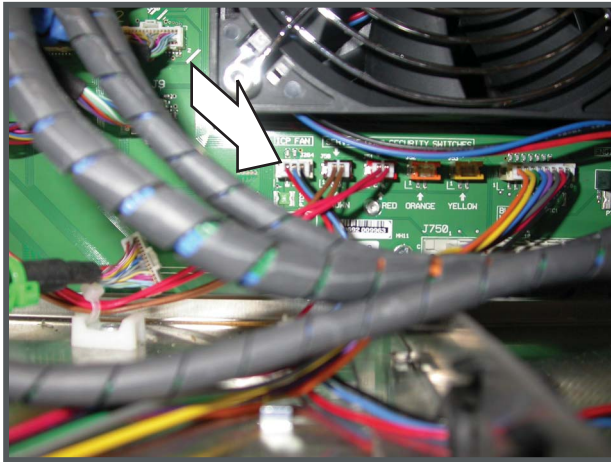

Image 21-33
Fan connection

2. To work handy it is recommended to slide out the intermediary plate a little bit. To it as follow:
 - a) cut the necessary wire ties.
 - b) turning out both fixation screws.
 - c) sliding the plate backwards.

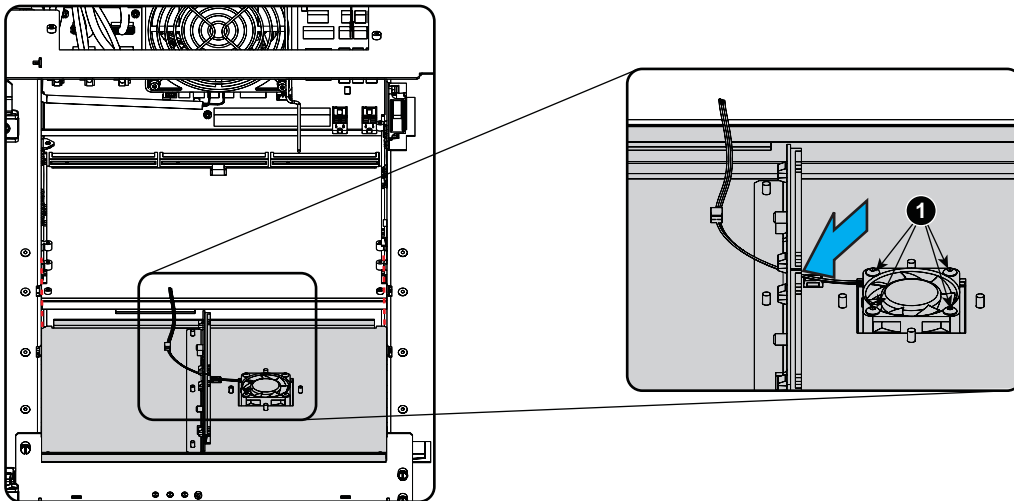

Image 21-34
Fan removal

3. Slide the cable through the hole in the intermediary plate.
4. Turn out the 4 fixation screws (reference 1).
5. Take off the fan.
6. Mount a new fan with the arrow indication pointing to the plate and drive in the 4 fixation screws.
7. Push the power cable through the hole in the plate.
8. Slide the intermediary plate back on its place and drive in both fixation screws.
9. Connect the power cable to the backplane. Secure the wires units with a few wire ties.

22. MAINTENANCE PROCEDURES

Overview

- Cleaning the exterior of the projector
- Removing the front dust filter
- Clean the dust filter on the top side

22.1 Cleaning the exterior of the projector

How to clean the exterior of the projector ?

1. Switch off the projector and unplug the projector from the mains power net.
2. Clean the housing of the projector with a damp cloth. Stubborn stains may be removed with a cloth lightly dampened with a mild detergent solution.

22.2 Removing the front dust filter



The front filter of the projector can be removed from the lamp side.



The filter can be cleaned.

Remove the dust filter

1. Remove the input cover of the projector, "Removal of the input cover", page 79.
2. Release the captive screw of the front cover.
Pull the left side of the front cover 5 centimeters forwards. There is no need to remove the cover completely.

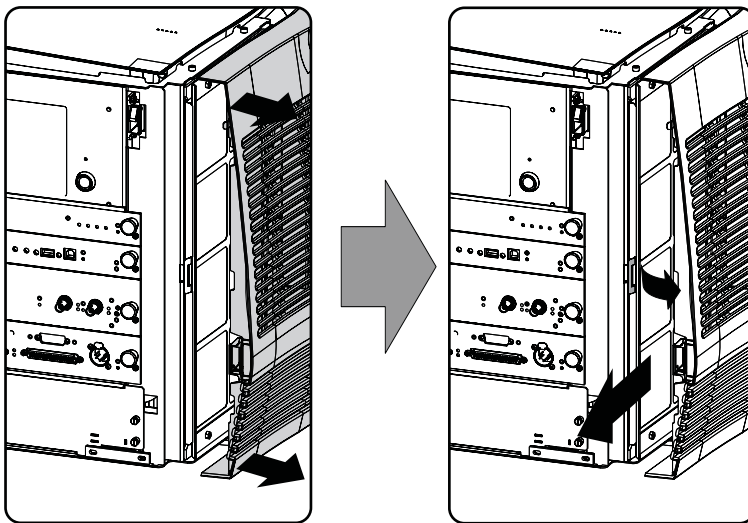

Image 22-1
Dust filter access

3. Pull the small handle a little backwards and then to the front of the projector until the filter frame is released.
4. Slide the filter to the left.

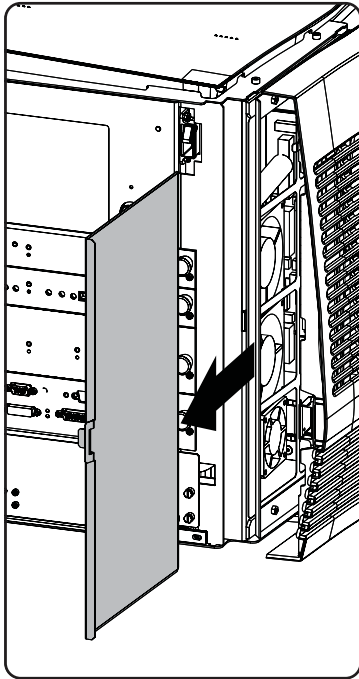

Image 22-2
Dust filter removal

Clean the dust filter

1. Remove most contamination with a vacuum cleaner in an other room or outside.
2. Blow remaining dust away with compressed air in an other room or outside.

Mount the dust filter

1. Insert the dust filter with the handle to the projector side.
2. Pull the handle a little backward, push the filter completely in. Release the handle so that it jumps in its lock.

22.3 Clean the dust filter on the top side

Remove the dust filter

1. Remove the side cover, see "Removal of the side cover", page 81.
2. Pull out the dust filter.

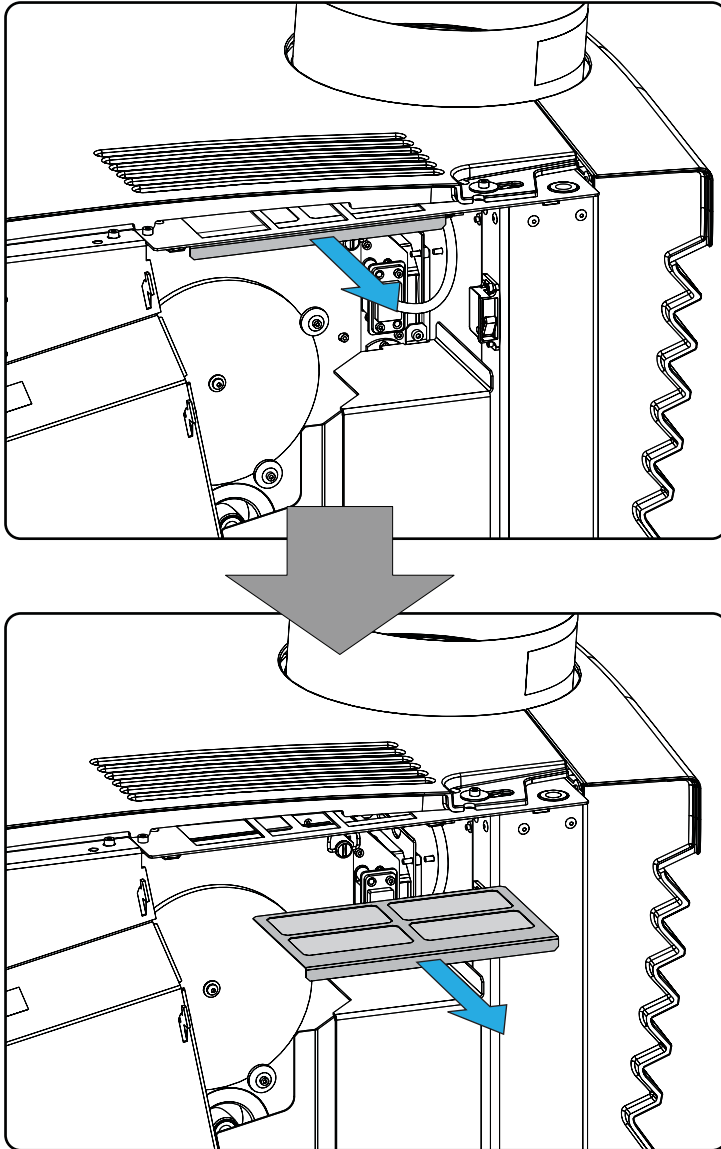

Image 22-3
Top dust filter

Clean the dust filter

1. Remove most contamination with a vacuum cleaner in an other room or outside.
2. Blow remaining dust away with compressed air in an other room or outside.

Mount the dust filter

1. Insert the dust filter and push on it until it is fully inserted.

A. PIN CONFIGURATIONS

Overview

- About General Purpose Inputs & Outputs (GPIO)
- Pin configurations of the communication ports
- Pin configurations of the ICMP communication ports
- Pin configurations of the inputs

A.1 About General Purpose Inputs & Outputs (GPIO)



The Barco Cinema Controller and the Barco ICMP are equipped with GPIO ports. The electrical specifications described in this chapter are the same for both GPIO ports.

General Purpose inputs

The Barco Cinema Controller and the Barco ICMP have each eight (8) opto-isolated general purpose inputs available. These inputs are used to trigger the execution of macro files. For more explanation about the association of a macro to a GPI, consult the user guide of the Communicator.

Input voltage

The inputs can be directly driven from a TTL or CMOS output.

- The shape of the pulse must be rectangular.
- The duration of the pulse must be at least 50 milliseconds (shorter pulses are considered as a switch bounce)
- Minimum voltage : $V_{min} = +5V$
- Maximum voltage : $V_{max} = +18V$

External power supply

When interfacing with contact closure outputs, an external power supply needs to be provided. Depending upon the configuration a suitable pull-up resistor needs to be added as well.

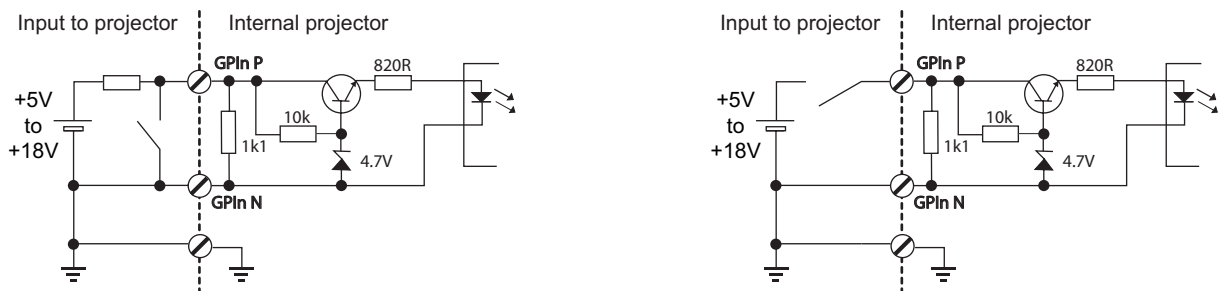

Image A-1

Cables

When long cable connections are required the use of shielded cables with twisted pairs is recommended. One twisted pair is to be assigned to each GP Input pair.

How to make the connection

When the power supply used to provide the DC voltage is isolated from ground (for example in the case of an AC adapter) it is recommended that the minus pole of that power supply is connected to ground (or to the projector chassis). This will avoid high common mode voltages at the projector GP Inputs. If that same power supply is used for other parts of the system, take care not to create ground loops. In any case when shielded cables are used that shield should be connected to the projector chassis.

General Purpose outputs

The Barco Cinema Controller and the Barco ICMP have each eight (8) opto-isolated outputs available. Four (4) of the outputs on the Cinema Controller are dedicated for TI. The other general purpose outputs can be controlled via software.

About an output

The output can generate a falling edge, rising edge, toggle or continuous toggle.

- **Generate Falling Edge** – generate a falling edge on the external GPO port if the present state of the output is high. If the present state of the external GPO is low, no edge will be generated.
- **Generate Rising Edge** – generate a rising edge on the external GPO port if the present state of the output is low. If the present state of the external GPO is high, no edge will be generated.
- **Generate Toggle** – generate a toggle on the external GPO port. If the present state of the output is low, a rising edge will be generated, followed by a falling edge. If the present state of the output is high, a falling edge will be generated, followed by a rising edge. Pulse width = 20 milliseconds.
- **Generate Continuous Toggle** - This command will generate a continuous toggle of the external GPO port. This toggle will continue until a *Generate Falling Edge*, *Generate Rising Edge*, or *Generate Toggle* command is received. The rate of toggle is 24Hz. .

Output transistor

- Maximum output driving voltage : $V_{\max} = 18 \text{ V}$
- Maximum current : $I_{\max} = 30 \text{ mA}$
- Maximum power dissipation : 120 mW

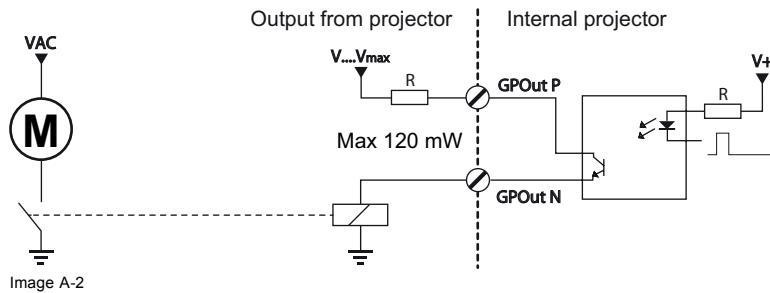

Image A-2



When the GPO driver inside the projector becomes powerless the GPO state changes to the default state. The default GPO state depends on the external system connected with the GPO port (pull-up or pull-down circuitry).

GPIO and projector Sleep mode

In case the projector is equipped with a "Sleep" mode (e.g. DP2K S series): Enter or leave Sleep mode can be done with GPIO of the Cinema Controller via two predefined Macros (not editable). Not with the GPIO of the ICMP.

The GPO signals of the ICMP will return to their default output level when the projector is switched to Sleep mode. This could generate unexpected "Falling Edge" triggers at the output pins. Also when awakening the projector (from Sleep mode to Standby mode) the GPO signals of the ICMP may generate unexpected "Rising Edge" events.

GPO and projector switching On or Off

The GPO signals of the Cinema Controller and ICMP will return to their default output level when the projector is switched to power-off. This could generate unexpected "Falling Edge" triggers at the output pins. Also during power-on the GPO signals may generate unexpected "Rising Edge" events.

A.2 Pin configurations of the communication ports

RS232IN

| RS232 IN | | | |
|----------|------------------------------------|---|---|
| 1 | - | 6 | - |
| 2 RXE- | Receive Data (RD or RX or RXD) | 7 | - |
| 3 TXE- | Transmitted Data (TD or TX or TXD) | 8 | - |
| 4 | - | 9 | - |
| 5 GND | Signal Ground (GND) | - | - |

General Purpose IN/OUT

| General Purpose In/Out | | | |
|------------------------|------------------------|----|------------------------|
| 1 | 3D Input Reference P | 20 | 3D Input Reference N |
| 2 | 3D Display Reference P | 21 | 3D Display Reference N |
| 3 | GPIN 3 P (reserved) | 22 | GPIN 3 N (reserved) |
| 4 | GPIN 4 P (reserved) | 23 | GPIN 4 N (reserved) |
| 5 | GPIN 5 P | 24 | GPIN 5 N |
| 6 | GPIN 6 P | 25 | GPIN 6 N |
| 7 | GPIN 7 P | 26 | GPIN 7 N |
| 8 | GPIN 8 P | 27 | GPIN 8 N |
| 9 | 3D Output Reference P | 28 | 3D Output Reference N |
| 10 | GPOUT 2 P (reserved) | 29 | GPOUT 2 N (reserved) |
| 11 | GPOUT 3 P (reserved) | 30 | GPOUT 3 N (reserved) |
| 12 | GPOUT 4 P | 31 | GPOUT 4 N |
| 13 | GPOUT 5 P | 32 | GPOUT 5 N |
| 14 | GPOUT 6 P | 33 | GPOUT 6 N |
| 15 | GPOUT 7 P | 34 | GPOUT 7 N |
| 16 | GPOUT 8 P | 35 | GPOUT 8 N |
| 17 | reserved | 36 | reserved |
| 18 | reserved | 37 | reserved |
| 19 | reserved | | |

Ethernet port

| Pin | Pair | Color | 10/100 Base-T — RJ45 port | 1000 Base-T — RJ45 port |
|-----|------|--------------|---------------------------|-------------------------|
| | | | Description | Description |
| 1 | 3 | white/green | TXD+ | TX0+ |
| 2 | 3 | green | TXD- | TX0- |
| 3 | 2 | white/orange | RXD+ | RX0+ |
| 4 | 1 | blue | — | TX1+ |
| 5 | 1 | white/blue | — | TX1- |
| 6 | 2 | orange | RXD- | RX0- |
| 7 | 4 | white/brown | — | Rx1+ |
| 8 | 4 | brown | — | RX1- |

Peripheral Port

| Pin | Name |
|-----|------|
| 1 | +5V |

| Pin | Name |
|-----|------|
| 2 | SCL |
| 3 | SDA |
| 4 | +24V |
| 5 | GND |

3D connector

| Pin | Name | Pin | Name |
|-----|----------------------|-----|------------------------|
| 1 | +12V | 9 | +12V |
| 2 | Grnd | 10 | 3D Input Reference - |
| 3 | Grnd | 11 | 3D Display Reference + |
| 4 | RS232 RX | 12 | 3D Display Reference - |
| 5 | RS232 TX | 13 | CONN_3D MODE - |
| 6 | CONN_3D_MODE + | 14 | CONN_SYNC - |
| 7 | CONN_SYNC + | 15 | - |
| 8 | 3D Input Reference + | | |

A.3 Pin configurations of the ICMP communication ports

RJ-45 pin configuration

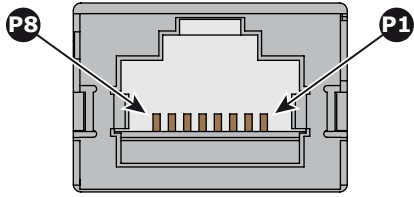

Image A-3

Audio Channels:

| AUDIO-AES 1-8 | | |
|---------------|----------|-----------|
| Audio channel | AES pair | RJ-45 pin |
| 1, 2 | 1 + | 1 |
| | 1 - | 2 |
| 3, 4 | 2 + | 3 |
| | 2 - | 6 |
| 5, 6 | 3 + | 4 |
| | 3 - | 5 |
| 7, 8 | 4 + | 7 |
| | 4 - | 8 |

| AUDIO-AES 9-16 | | |
|----------------|----------|-----------|
| Audio channel | AES pair | RJ-45 pin |
| 9, 10 | 5 + | 1 |
| | 5 - | 2 |
| 11, 12 | 6 + | 3 |
| | 6 - | 6 |
| 13, 14 | 7 + | 4 |
| | 7 - | 5 |
| 15, 16 | 8 + | 7 |
| | 8 - | 8 |

General Purpose Output:

| GPO 1-4 | |
|---------------|-----------|
| Definition | RJ-45 pin |
| EXT_GPOUT_1_P | 1 |
| EXT_GPOUT_1_N | 2 |
| EXT_GPOUT_2_P | 3 |
| EXT_GPOUT_2_N | 4 |
| EXT_GPOUT_3_P | 5 |
| EXT_GPOUT_3_N | 6 |
| EXT_GPOUT_4_P | 7 |
| EXT_GPOUT_4_N | 8 |

| GPO 5-8 | |
|---------------|-----------|
| Definition | RJ-45 pin |
| EXT_GPOUT_5_P | 1 |
| EXT_GPOUT_5_N | 2 |

| GPO 5-8 | |
|---------------|-----------|
| Definition | RJ-45 pin |
| EXT_GPOUT_6_P | 3 |
| EXT_GPOUT_6_N | 4 |
| EXT_GPOUT_7_P | 5 |
| EXT_GPOUT_7_N | 6 |
| EXT_GPOUT_8_P | 7 |
| EXT_GPOUT_8_N | 8 |

General Purpose Input:

| GPI 1-4 | |
|--------------|-----------|
| Definition | RJ-45 pin |
| EXT_GPIN_1_P | 1 |
| EXT_GPIN_1_N | 2 |
| EXT_GPIN_2_P | 3 |
| EXT_GPIN_2_N | 4 |
| EXT_GPIN_3_P | 5 |
| EXT_GPIN_3_N | 6 |
| EXT_GPIN_4_P | 7 |
| EXT_GPIN_4_N | 8 |

| GPI 5-8 | |
|--------------|-----------|
| Definition | RJ-45 pin |
| EXT_GPIN_5_P | 1 |
| EXT_GPIN_5_N | 2 |
| EXT_GPIN_6_P | 3 |
| EXT_GPIN_6_N | 4 |
| EXT_GPIN_7_P | 5 |
| EXT_GPIN_7_N | 6 |
| EXT_GPIN_8_P | 7 |
| EXT_GPIN_8_N | 8 |

About 568A and 568B on an Ethernet connector RJ-45

TIA/EIA-568A and -568B are two standards for connecting Category 3 and Category 5 wire to connectors. Both are appropriate for high speed data, though 568B is somewhat more common for installed wiring and 568A is more common in jumpers. There is no performance advantage either way. The only real difference between the two is the order in which the pairs are used (orange and green).

Hold a cable as if to plug it into a wall jack, the locking tab down (contacts facing you). The contacts are numbered 1-8 from left to right. Here's what you will see:

| RJ-45 Pin Number (Left >Right copper side) | 568A | 568B | AES -1-8 |
|---|--------------|--------------|----------------|
| 1 | White/Green | White/Orange | AES 1&2 +plus |
| 2 | Green | Orange | AES 1&2 +minus |
| 3 | White/Orange | White/Green | AES 3&4 +plus |
| 4 | Blue | Blue | AES 5&6 +minus |
| 5 | White/Blue | White/Blue | AES 5&6 +plus |
| 6 | Orange | Green | AES 3&4 +minus |
| 7 | White/Brown | White/Brown | AES 7&8 +plus |
| 8 | Brown | Brown | AES 7&8 +minus |

A. Pin configurations

568A and 568B may be used interchangeably in a system SO LONG AS both ends of a given cable are terminated the same way.

568A + 568B wiring is a crossover cable.

568A + 568A wiring is a straight cable.

568B + 568B wiring is a straight cable.

The mapping of the channels is done according to the Ethernet wiring scheme and gives us 100 Ohm per pair.

A.4 Pin configurations of the inputs

DVI-D

| DVI IN A & B | | | | | | | |
|--------------|------------|----|------------|----|-----------------|----|-------------------|
| 1 | RX2- | 7 | DDC Data | 13 | nc | 19 | RX0 Shield |
| 2 | RX2+ | 8 | nc | 14 | +5V | 20 | nc |
| 3 | RX2 Shield | 9 | RX1- | 15 | GND | 21 | nc |
| 4 | nc | 10 | RX1+ | 16 | Hot Plug Detect | 22 | TMDS Clock Shield |
| 5 | nc | 11 | RX1 Shield | 17 | RX0- | 23 | TMDS RXC+ |
| 6 | DDC Clock | 12 | nc | 18 | RX0+ | 24 | TMDS RXC- |

B. INPUT FORMATS

B.1 Input formats

DVI Input formats

| Input | Source standard | Vertical rate | Scan type | Color space | Sampling | Color depth |
|------------|------------------|---------------|-------------|-------------|----------|-------------|
| Single DVI | VESA (640x480) | 60 | Progressive | RGB | 4:4:4 | 8 bit |
| Single DVI | VESA (640x480) | 72 | Progressive | RGB | 4:4:4 | 8 bit |
| Single DVI | VESA (800x600) | 60 | Progressive | RGB | 4:4:4 | 8 bit |
| Single DVI | VESA (800x600) | 72 | Progressive | RGB | 4:4:4 | 8 bit |
| Single DVI | VESA (1024x768) | 60 | Progressive | RGB | 4:4:4 | 8 bit |
| Single DVI | VESA (1024x768) | 70 | Progressive | RGB | 4:4:4 | 8 bit |
| Single DVI | VESA (1280x1024) | 60 | Progressive | RGB | 4:4:4 | 8 bit |
| Single DVI | 1280x720 | 60 | Progressive | RGB | 4:4:4 | 8 bit |
| Single DVI | 1920x1080 | 60 | Progressive | RGB | 4:4:4 | 8 bit |
| Single DVI | 2048x1080 | 50/60 | Progressive | RGB | 4:4:4 | 8 bit |
| Single DVI | 1920x1080i | 50/60 | Interlaced | RGB | 4:4:4 | 8 bit |
| Twin DVI | ACS (2048x1080) | 50/59.94 | Progressive | RGB | 4:4:4 | 10 bit |
| Twin DVI | ACS (2048x1080) | 50/59.94 | Progressive | RGB | 4:4:4 | 12 bit |

SMPTE 274M

| System no | System nomenclature | Luma or RGB samples per active line (S/AL) | Active lines per frame (AL/F) | Frame rate (Hz) | Interface sampling frequency fs (MHz) | Luma sample periods per total line (S/TL) | Total lines per frame |
|-----------|---------------------|--|-------------------------------|-----------------|---------------------------------------|---|-----------------------|
| 4 | 1920 x 1080/60/I | 1920 | 1080 | 30 | 74.25 | 2200 | 1125 |
| 5 | 1920 x 1080/59.94/I | 1920 | 1080 | 30/1.001 | 75.25/1.001 | 2200 | 1125 |
| 6 | 1920 x 1080/50/I | 1920 | 1080 | 50 | 74.25 | 2640 | 1125 |
| 7 | 1920 x 1080/30P | 1920 | 1080 | 30 | 74.25 | 2200 | 1125 |
| 8 | 1920 x 1080/29.97/P | 1920 | 1080 | 30/1.001 | 74.25/1.001 | 2200 | 1125 |
| 9 | 1920 x 1080/25/P | 1920 | 1080 | 25 | 74.25 | 2640 | 1125 |
| 10 | 1920 x 1080/24/P | 1920 | 1080 | 24 | 74.25 | 2750 | 1125 |
| 11 | 1920 x 1080/23.98/P | 1920 | 1080 | 24/1.001 | 74.25/1.001 | 2750 | 1125 |

SMPTE 296M

| System no | System nomenclature | Luma or RGB samples per active line (S/AL) | Active lines per frame (AL/F) | Frame rate (Hz) | Interface sampling frequency fs (MHz) | Luma sample periods per total line (S/TL) | Total lines per frame |
|-----------|---------------------|--|-------------------------------|-----------------|---------------------------------------|---|-----------------------|
| 1 | 1280 x 720/60 | 1280 | 720 | 60 | 74.25 | 1650 | 750 |
| 2 | 1280 x 720/59.94 | 1280 | 720 | 60/1.001 | 74.25/1.001 | 1650 | 750 |
| 3 | 1280 x 720/50 | 1280 | 720 | 50 | 74.25 | 1980 | 750 |
| 4 | 1280 x 730/30 | 1280 | 720 | 30 | 74.25 | 3300 | 750 |
| 5 | 1280 x 720/29.97 | 1280 | 720 | 30/1.001 | 74.25/1.001 | 3300 | 750 |
| 6 | 1280 x 720/25 | 1280 | 720 | 25 | 74.25 | 3960 | 750 |
| 7 | 1280 x 720/24 | 1280 | 720 | 24 | 74.25 | 4125 | 750 |
| 8 | 1280 x 720/23.98 | 1280 | 720 | 24/1.001 | 74.25/1.001 | 4125 | 750 |

SMPTE 260M

The system nomenclature for SMPTE 260M is 1920 x 1035 (1035 active lines) constrained to 60/60/1.001. All other parameters are the same as for SMPTE 274M.

INDEX

A

- Access 277
 - Mains 277
- Activate 157
 - LUT-SCC file 157
- Adjust 131
 - Cold mirror 131
- Authorization 253
 - Security warning 253
 - Clear 253
- Available 186
 - Lenses 186
 - Types 186

B

- Block diagrams 15
- Board insertion 222
 - Card cage 222
- Board removal 221
 - Card cage 221
- Button module 231
- Button unit 227, 230, 239
 - Installation 230
 - Remove 227
 - Signal back plane 239
 - Replace 239

C

- Card cage 216–219, 221–222
 - Cinema controller 219
 - Fan controller 216
 - HD-SDI 218
 - ICP 217
 - Insert board 222
 - Link decryptor 218
 - Remove board 221
- Card Cage 215
- Cinema controller 219
- Cinema Controller 225
 - Battery 225
 - Replacement 225
- Clean 121–122, 133, 156
 - Cold Mirror 133
 - Prism 156
 - Reflector 121
 - UV blocker 122
- Clean dust filter 341, 343
 - Front side 341
 - Top side 343
- Cleaning 192, 340
 - Exterior 340
 - Lens 192
- Close 86, 283
 - Mains Input 283
 - Sealed compartment 86
- Cold mirror 123–125, 129, 131, 335
 - Adjust 131
 - Diagnostic 124
 - Fan 335
 - Functionality 124
 - Installation 129
 - Introduction 124
 - Removal 125
- Cold Mirror 127, 133
 - Clean 133
 - Replace 127
- Communicator 269
- Convention 10
 - Orientation 10
- Convergence 165–169, 171

- Controls 166
 - Green on Blue 171
 - Prepare 168
 - Red on Blue 169
 - Test pattern 167
- Covers 77

D

- DC update companion 256
 - Launch 256
- Download 160
 - LUT-SCC file 160
- Dowser 152
- Dust filter 341, 343
 - Front side 341
 - Clean 341
 - Top side 343
 - Clean 343

E

- Electrical disconnection 140
 - Light processor assembly 140
- Error code name 29, 31–63, 65–73
 - ++12v - voltage high 71
 - ++12v - voltage low 72
 - +24v - voltage high 71
 - +24v - voltage low 71
 - +24v - voltage too low 71
 - 5043 32
 - ambient - temperature high 43
 - ambient - temperature low 43
 - ambient - temperature sensor open 43
 - ambient - temperature sensor short 43
 - ambient - temperature too high 43
 - cold mirror fan - speed too low 32
 - cold mirror fan - voltage high 51
 - cold mirror fan - voltage low 51
 - cold mirror fan - voltage too low 51
 - dmd - temperature hardware protection warning 70
 - dmd blue - temperature high 44
 - dmd blue - temperature low 44
 - dmd blue - temperature sensor open 44
 - dmd blue - temperature sensor short 45
 - dmd blue - temperature too high 44
 - dmd blue fan - voltage high 50
 - dmd blue fan - voltage low 51
 - dmd blue fan - voltage too low 50
 - dmd green - temperature high 45
 - dmd green - temperature low 45
 - dmd green - temperature sensor open 45
 - dmd green - temperature sensor short 46
 - dmd green - temperature too high 45
 - dmd green fan - voltage high 50
 - dmd green fan - voltage low 50
 - dmd green fan - voltage too low 50
 - dmd red - temperature high 48
 - dmd red - temperature low 48
 - dmd red - temperature sensor open 48
 - dmd red - temperature sensor short 49
 - dmd red - temperature too high 48
 - dmd red fan - speed low 41–43
 - dmd red fan - voltage high 49
 - dmd red fan - voltage low 50
 - dmd red fan - voltage too low 49
 - dowser - set dowser open failed 60
 - electronics fan 1 (top side) - speed low 36
 - electronics fan 1 (top side) - voltage high 56
 - electronics fan 1 (top side) - voltage low 56
 - electronics fan 1 (top side) - voltage too low 56
 - electronics fan 2 (bottom side) - voltage high 57

| | | | |
|--|----|--|------------------|
| electronics fan 2 (bottom side) - voltage low | 57 | ti-icp - key error | 66 |
| electronics fan 2 (bottom side) - voltage too low | 57 | ti-icp - read satellite info failed | 63 |
| engine fan - speed low | 33 | ti-icp - read system status failed | 63 |
| engine fan - voltage high | 52 | ti-icp - satellite firmware mismatch | 63 |
| engine fan - voltage low | 52 | ti-icp - self test = fail | 65 |
| engine fan - voltage too low | 52 | ti-link-decryptor - logical marriage tamper event | 68 |
| engine switch - not ok | 37 | ti-link-decryptor - no communication | 66 |
| fcv - force lps/lamp off (overtemperature, lamp house not connected or engine not connected) | 47 | ti-link-decryptor - physical marriage tamper event | 68 |
| icp fan - speed low | 72 | ti-link-decryptor - read system status failed | 68 |
| icp fan - voltage high | 73 | ti-link-decryptor - security log almost full | 68 |
| icp fan - voltage low | 73 | ti-link-decryptor - security log is full | 68 |
| imb - logical marriage tamper event | 69 | ti-link-decryptor - security tamper event | 67 |
| imb - no communication | 68 | ti-link-decryptor - service door tamper event | 62 |
| imb - physical marriage tamper event | 69 | ti-link-decryptor - system error | 66 |
| imb - service door tamper event | 69 | Error code number | 29, 31–63, 65–73 |
| lamp - lamp is off due to an error | 60 | 5003 | 29 |
| lamp - no communication | 29 | 5004 | 29 |
| lamp - set lamp on failed | 60 | 5005 | 31 |
| lamp - temperature high | 46 | 5020 | 32 |
| lamp - temperature sensor open | 46 | 5042 | 32 |
| lamp - temperature sensor short | 47 | 5053 | 33 |
| lamp - temperature too high | 46 | 5072 | 33 |
| lamp anode fan - speed low | 34 | 5073 | 34 |
| lamp anode fan - speed too low | 33 | 5082 | 34 |
| lamp anode fan - voltage high | 53 | 5083 | 35 |
| lamp anode fan - voltage low | 53 | 5103 | 35 |
| lamp anode fan - voltage too low | 53 | 5113 | 36 |
| lamp cathode fan - speed low | 35 | 5123 | 36 |
| lamp cathode fan - speed too low | 34 | 5143 | 36 |
| lamp cathode fan - voltage high | 54 | 5160 | 37 |
| lamp cathode fan - voltage low | 54 | 5180 | 37 |
| lamp cathode fan - voltage too low | 54 | 5191 | 38 |
| lamp house - not connected | 37 | 5230 | 38 |
| lamp power supplies - at least one lamp power supply could not be detected | 59 | 5231 | 39 |
| lamp power supplies - communication failed | 31 | 5232 | 40 |
| lamp power supplies - communication failed with at least one lamp power supply | 59 | 5233 | 41 |
| lamp power supplies - lamp is on, but smps is off | 59 | 5253 | 41 |
| lamp power supplies - zero lamp power supplies detected | 58 | 5263 | 42 |
| lamp rear fan - speed low | 36 | 5273 | 43 |
| lamp rear fan - voltage high | 55 | 5280 | 43 |
| lamp rear fan - voltage low | 56 | 5281 | 43 |
| lamp rear fan - voltage too low | 55 | 5283 | 43 |
| lamp run time - exceeds maximum | 60 | 5284 | 43 |
| lamp run time - read failed | 60 | 5285 | 43 |
| lamp run time - read limits failed | 60 | 5290 | 44 |
| lamp run time - warning | 60 | 5291 | 44 |
| lens - no lens parameter file has been activated | 73 | 5293 | 44 |
| lens focus position - requested target not reached | 39 | 5294 | 44 |
| lens horizontal shift position - requested target not reached | 40 | 5295 | 45 |
| lens motors - voltage too low | 72 | 5300 | 45 |
| lens vertical shift position - requested target not reached | 41 | 5301 | 45 |
| lens zoom position - requested target not reached | 38 | 5303 | 45 |
| light pipe - temperature high | 69 | 5304 | 45 |
| light pipe - temperature sensor open | 70 | 5305 | 46 |
| light pipe - temperature sensor short | 70 | 5310 | 46 |
| light pipe - temperature too high | 69 | 5311 | 46 |
| light sensor - no communication | 29 | 5314 | 46 |
| maintenance - maintenance required | 73 | 5315 | 47 |
| pfc heatsink - temperature high | 48 | 5320 | 47 |
| prism switch - warning (lens probably touches prism) | 38 | 5331 | 48 |
| smcps fan - voltage high | 55 | 5340 | 48 |
| smcps fan - voltage low | 55 | 5341 | 48 |
| smcps fan - voltage too low | 55 | 5343 | 48 |
| smcps fan 1 (left side) - speed low | 35 | 5344 | 48 |
| smcps fan 2(right side) - speed low | 36 | 5345 | 49 |
| smcps primary heatsink - temperature high | 49 | 5351 | 49 |
| smcps secondary heatsink - temperature high | 49 | 5361 | 49 |
| smcps secondary heatsink - temperature sensor open | 49 | 5364 | 49 |
| smcps secondary heatsink - temperature sensor short | 49 | 5365 | 49 |
| system - read projector identification failed | 32 | 5371 | 49 |
| ti-boards - system status = fail | 61 | 5372 | 49 |
| ti-icp - certificate error | 65 | 5373 | 50 |
| ti-icp - icp board not detected | 66 | 5381 | 50 |
| | | 5382 | 50 |
| | | 5383 | 50 |
| | | 5391 | 50 |

- 5392 50
5393 51
5431 51
5432 51
5433 51
5441 52
5442 52
5443 52
5461 53
5462 53
5463 53
5471 54
5472 54
5473 54
5491 55
5492 55
5493 55
5571 55
5572 55
5573 56
5611 57
5621 56
5622 56
5623 56
5632 57
5633 57
5640 58
5641 59
5642 59
5643 59
5646 60
5647 60
5654 60
5657 60
5658 60
5659 60
5670 60
5800 61
5801 62
5807 63
5812 63
5813 63
5814 65
5815 65
5816 66
5817 66
5830 66
5831 66
5832 67
5833 68
5834 68
5835 68
5836 68
5837 68
5850 68
5851 69
5853 69
5854 69
5960 69
5961 69
5964 70
5965 70
6050 70
6061 71
6062 71
6063 71
6071 71
6073 72
6082 72
6123 72
6131 73
6133 73
6200 73
6210 73
cold mirror fan - speed low 32
Ethernet 219
Exterior 340
Cleaning 340
- F**
Fan 320, 322, 324, 327, 332, 335, 337–338
Card cage fans 320
Cold mirror 335
ICP fan 338
Lamp anode 332
Lamp cathode 327
Lamp Info 337
Light processor compartment fan 324
SMPS fans 322
Fan controller 216
Fan replacement 319
File manager 162–163
Activate 163
LUT-SCC file 163
File upload 162
Flight case 142, 148
Light processor 142
Remove 142
Light processor assembly 148
Mount 148
Front cover 80, 90
Install 90
Remove 80
- G**
General 9
General Purpose I/O 220, 346
GPIO 220, 346
- H**
HD-SDI board 218
Horizontal Shift 205
Stepper motor 205
Replace 205
- I**
ICMP software update 259
ICP board 217
ICP software update 263
Input cover 79, 91
Install 91
Remove 79
Input formats 355, 357
Install 87–91, 115, 152, 254, 272, 297
Dowser 152
Front cover 90
Input cover 91
LPS 297
Rear cover 88
Shutter 152
Side cover 89
Status Light 254
Top cover 87
Touch panel 272
UV blocker 115
Installation 316
SPG 316
Integration rod 174–175, 179
Diagnostic 175
Installation 179
Introduction 174
Integrator rod 173, 176, 183
Adjust 183
Removal 176
Introduction 158
SCC file 158

K

Keypad 234, 238

L

Lamp 93–94, 96, 102, 110–111
 Install 102
 Introduction 94
 Realignment 111
 Remove 96
 Reset 110
 Lamp anode 332
 Fan 332
 Lamp cathode 327
 Fan 327
 Lamp cover 78
 Remove 78
 Lamp house 93–94, 96, 108, 118
 Installation 108
 Introduction 94
 Reflector 118
 Remove 96
 Lamp House 121–122
 Reflector 121
 Clean 121
 UV blocker 122
 Clean 122
 Lamp Info 337
 Fan 337
 Lamp info module 113
 Replace 113
 Lamp power supply 291, 299
 Single module 299
 Lens 189–190, 192, 199
 Cleaning 192
 Install 190
 Removal 189
 Scheimpflug 199
 Lens holder 185, 193, 196, 203
 Installation 196
 Remove 193
 Vertical Shift 203
 Stepper motor 203
 Lens Holder 207, 211
 Lens Rubber 207, 211
 kit 207, 211
 Lens Rubber 207, 211
 kit 207, 211
 Lens Holder 207, 211
 lens selection 188
 Lenses 185
 Light processor 135–136, 138, 142, 150–151, 154, 176, 179, 183
 Diagnostic 138
 Finalize installation 150
 Flight case 142
 Remove 142
 Integrator rod 176, 179, 183
 Adjust 183
 Installation 179
 Removal 176
 Introduction 136
 Light Sensor module 151
 Notch filter 154
 Light processor assembly 140–141, 144, 146, 148
 Electrical connections 146
 Electrical disconnection 140
 Flight case 148
 Mount 148
 Installation 144
 Remove 141
 Light processor cover 147
 Mount 147
 Light processor top cover 139
 Remove 139
 Link decryptor 218, 251

Replace 251
 Link decryptor software update 266
 Location 11
 Main components 11
 LPS 291–293, 295, 297, 299–300, 302, 304, 307
 Diagnostic 293, 300
 Install 297
 Installation 304
 Introduction 292
 Large frame 307
 Replacement 307
 Removal 302
 Remove 295
 Single module 299
 LUT-SCC file 157, 160
 Activate 157
 Download 160

M

Main components 11
 Location 11
 Mains filter 281
 Replace 281
 Maintenance 19, 21–23, 26, 256, 259, 263, 266, 268, 339
 4 yearly 26
 Annually 23
 Lamp change 21
 Preventative actions 19
 Software upgrade 256, 259, 263, 266, 268
 ICMP software 259
 ICP software 263
 Launch DC update companion 256
 Link decryptor 266
 Log file 268
 Projector software 259
 Touch panel software 259
 Three monthly 22
 Maintenance actions 20
 Monthly 20

O

Obtain 159
 Serial Number 159
 ON/OFF switch 279
 Replace 279
 Open 85
 Sealed compartment 85
 Orientation 10
 Convention 10

P

Pin configuration 348, 353
 Communication ports 348
 Inputs 353
 Pin configurations 345, 350
 ICMP 350
 Position 274
 Touch panel 274
 Power input 275–276
 Introduction 276
 Preventative maintenance 19
 Prism 156
 Clean 156
 Projector software update 259
 Projector status light 14
 About 14

R

Realignment 111
 Lamp 111
 Rear cover 82, 88

Install 88
 Remove 82
 Reflector 118, 121
 Clean 121
 Replace 118
 Remove 78–83, 98, 152, 254, 295, 314
 Dowser 152
 Front cover 80
 Input cover 79
 Lamp cover 78
 LPS 295
 Rear cover 82
 Shutter 152
 Side cover 81
 SPG 314
 Status Light 254
 Top cover 83
 Xenon lamp 98
 Replace 113, 118, 127, 152, 205, 223, 225, 254, 279, 281
 Battery 225
 Cinema Controller 225
 Cold Mirror 127
 Dowser 152
 Horizontal Shift 205
 Stepper motor 205
 Lamp info module 113
 Mains filter 281
 ON/OFF switch 279
 Reflector 118
 RTC battery 223
 ICMP board 223
 Shutter 152
 Status Light 254
 replacement 231, 234, 238
 Reset 110
 Lamp 110
 Rod 175
 Diagnostic 175
 RS232 220

S

Safety 5–6
 Instructions 6
 SCC file 158
 Introduction 158
 Scheimpflug 199
 second generation Keypad 231, 234, 238
 Serial communication 220
 Shutter 152
 Signal back plane 239
 Replace 239
 SMPS 287–289
 Diagnostics 288
 Replacement 289

Software update 255, 259, 263, 266, 268
 DC update companion 255
 ICMP software 259
 ICP software 263
 Link decryptor 266
 Log file 268
 Projector software 259
 Touch panel software 259
 Via Communicator 255
 Software upgrade 256
 DC update companion 256
 Launch 256
 Spare parts 17
 SPG 312–314, 316
 Installation 316
 Introduction 312
 Remove 314
 Troubleshooting 313
 Start Pulse Generator 311
 Status light 14
 About 14
 Status Light 254
 Replace 254
 Switched mode power supply 287–289
 Diagnostics 288
 Replacement 289

T

Test Pattern 167
 Convergence 167
 Top cover 83, 87
 Install 87
 Remove 83
 Touch panel 269–270, 272, 274
 Install 272
 Introduction 270
 Position 274
 Touch panel software update 259
 Troubleshooting 27, 29, 74, 313
 Checklist 29
 Log files 74
 SPG 313

U

UV blocker 122
 Clean 122

V

Vertical Shift 203
 Stepper motor 203
 Lens holder 203